



MINISTRY OF  
**ELECTRONICS AND  
INFORMATION TECHNOLOGY**  
GOVERNMENT OF INDIA

सत्यमेव जयते



**ERNET** India  
Education & Research Network

**AADHAAR**

**SAMEER**  
Passion for performance

**मेरी सरकार**  
**my GOV**

**एनआईसी**  
**NIC**

**सीमेट**  
**MET**

**DigiLocker**  
Document Wallet to Empower Citizens

**मेरी सरकार**

**GeM**  
Government e Marketplace

रा.इ.सू.प्रौ.सं  
**NIELIT**

**API Setu**

**NeGD**  
National e-Governance Division

Efficient • Transparent • Inclusive

**BHASHINI**

**BISAG-N**

**Meri Pehchaan**  
SINGLE SIGN-ON SERVICE

**CSC**  
e-Governance Services India Limited

**EntityLocker**  
Document Wallet to Empower Entities

**Aarogya Setu**  
मे सुरक्षित। हम सुरक्षित। भारत सुरक्षित

**DIGIDHAN**

**MeitY Startup Hub**

**nixi**

**taal**

**UMANG**

**certm**  
Handling Computer Security Incidents

**eoffice**  
A DIGITAL WORKPLACE SOLUTION

**DIKSHA**

**STQC**  
Controller of Certifying Authorities

**LUPI**  
UNIFIED PAYMENTS INTERFACE

**BHIM**  
BHARAT INTERFACE FOR MONEY

**Poshan Tracker**

# Annual Report

2025-2026



Annual  
**REPORT**  
2025-2026



सत्यमेव जयते

**MINISTRY OF ELECTRONICS & INFORMATION TECHNOLOGY  
GOVERNMENT OF INDIA**



## Shri Ashwini Vaishnaw

Hon'ble Minister of Railways;  
Information and Broadcasting, and  
Ministry of Electronics & Information  
Technology, Government of India



## Shri Jitin Prasada

Hon'ble Minister of State in the  
Ministry of Commerce & Industry, and  
Ministry of Electronics & Information Technology,  
Government of India



## Shri S. Krishnan

Secretary  
Ministry of Electronics & Information Technology,  
Government of India

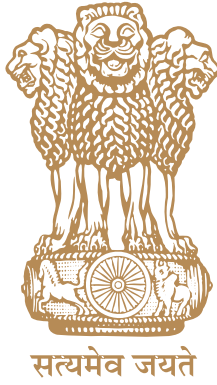

# CONTENTS

<b>Executive Summary</b>	<b>11-14</b>
<b>1. Overview of MeitY: Vision, Mission, Objective, Structure and Functions of MeitY</b>	<b>15-18</b>
1.1 Introduction	
1.2 Vision	
1.3 Mission	
1.4 Objectives	
1.5 Functions	
1.6 Work Allocation	
1.7 Organisation Structure	
<b>2. Digital India: Power to Empower</b>	<b>19-78</b>
2.1 Introduction	
2.1.1 Extension of Digital India Programme	
2.1.2 Vision of Digital India	
2.2 Digital Infrastructure	
2.2.1 Digital Identity	
2.2.2 Enhancement of National Informatics Centre (NIC) National Cloud Services	
2.2.3 National Data Centre in North-East Region (NDC-NER)	
2.2.4 GI Cloud (MeghRaj)	

- 2.2.5 Bhaskaracharya National Institute for Space Applications and Geo-informatics (BISAG-N)
- 2.3 Mobile based online Governance and Services on Demand
  - 2.3.1 India Portal
  - 2.3.2 User experience for Government (Websites & Apps) UI/UX 4G
  - 2.3.3 DigiLocker: Revolutionizing Paperless Governance
  - 2.3.4 Electronic Transaction Aggregation and Analysis Layer 3.0 (eTaal 3.0)
  - 2.3.5 Vikaspedia 2.0
  - 2.3.6 Implementation of National Data Highway (NDH)/ API Setu
  - 2.3.7 Pragati VC 2.0
  - 2.3.8 myScheme
  - 2.3.9 Gov.in Secure Intranet Portal
  - 2.3.10 Prayas 2.0
  - 2.3.11 Bharat Data Exchange (Bharat X)
  - 2.3.12 e-Governance Standards and Guidelines
  - 2.3.13 Unified Mobile Application for New-Age Governance (UMANG)
  - 2.3.14 Virtual Reality-Based Assistive System for Learning and Assessment of Persons with Intellectual Disabilities (Divyang SARTHI)
  - 2.3.15 CollabFiles
  - 2.3.16 GovDrive – Storage as a Service
  - 2.3.17 Kisan Sarathi 2.0: Enhancement, Operations Maintenance and Support
- 2.4 Digital Empowerment
  - 2.4.1 Collaboration Application Development Platform by opening the Source Code of Government Applications (Open Forge)
  - 2.4.2 National Knowledge Network (NKN)
  - 2.4.3 Integrated Citizen Engagement Platform (InCEP)/MyGov 2.0
  - 2.4.4 Digital India Common Services Centre
  - 2.4.5 Digital India BHASHINI
  - 2.4.6 Capacity Building Scheme
  - 2.4.7 E-Greeting Portal and Sampark 2.0
  - 2.4.8 Awareness and Communication plan for Digital India

- 2.4.9 Modernisation/ digitalisation of Nagaland Fire & Emergency-  
Management system (NFES-MS)
- 2.4.10 GOV.IN Appstore
- 2.4.11 National Informatics Centre Services Incorporated (NICS)
- 2.4.12 Gov.In: Harmonisation of Government of India's Digital Footprint
- 2.4.13 Digital Economy
- 2.5 Digital India Initiatives by NIC
  - 2.5.1 Agriculture & Food Processing
  - 2.5.2 Health & Family Welfare
  - 2.5.3 Finance
  - 2.5.4 Education
  - 2.5.5 E-Transport
  - 2.5.6 Inclusive Development
  - 2.5.7 Consumer Affairs and Food & Public Distribution
  - 2.5.8 Law & Justice
  - 2.5.9 Home Affairs
  - 2.5.10 Culture and Tourism
  - 2.5.11 Labor & Employment
  - 2.5.12 New & Renewable Energy
  - 2.5.13 Good Governance & Enforcement

### 3. Make in India: Electronics Manufacturing

79-102

- 3.1 National Policy on Electronics, 2019
- 3.2 Growth of Electronics Sector
  - 3.2.1 Mobile Phones
  - 3.2.2 Information & Communication Technology (ICT) Hardware
  - 3.2.3 Consumer Electronics
  - 3.2.4 Strategic Electronics
  - 3.2.5 Industrial Electronics
  - 3.2.6 Automotive Electronics
  - 3.2.7 Electronic Components
  - 3.2.8 Medical Electronics

- 3.3 Schemes and programs
  - 3.3.1 Electronics Component Manufacturing Scheme (ECMS)
  - 3.3.2 Modified Special Incentive Package Scheme (M-SIPS)
  - 3.3.3 Electronic Cluster Manufacturing (EMC) Schemes
  - 3.3.4 Modified Electronics Manufacturing Clusters (EMC 2.0) Scheme
  - 3.3.5 Electronics Development Fund (EDF)
  - 3.3.6 Production Linked Incentive Scheme (PLI) for Large Scale Electronics Manufacturing
  - 3.3.7 PLI Scheme 2.0 for IT Hardware
  - 3.3.8 Scheme for Promotion of Manufacturing of Electronic Components and Semiconductors (SPECS)
  - 3.3.9 Programme for Development of Semiconductors and Display Manufacturing Ecosystem in India
  - 3.3.10 Investment Promotion to Attract Investment in ESDM Sector
  - 3.3.11 Other programs
  - 3.3.12 Centre of Excellence in Electronics and ICT application
- 4. International Cooperation 103-110**
  - 4.1 Multilateral Cooperation
  - 4.2 Key Achievements
  - 4.3 Bilateral Cooperation
  - 4.4 Major bilateral engagements
- 5. Innovate and Design in India 111-170**
  - 5.1 Artificial Intelligence & Emerging Technology
    - 5.1.1 Promoting the Adoption of Cutting-edge Technologies to Create Significant Economic and Societal Impact
    - 5.1.2 Quantum Technology
  - 5.2 Creation of Research Eco-System
    - 5.2.1 National Supercomputing Mission (NSM) & High-Performance Computing (HPC)
    - 5.2.2 R&D and IP Development
  - 5.3 Translation R&D
    - 5.3.1 Initiatives under Electronics Components and Material Development (EMDP)
    - 5.3.2 Technology Development & Demonstration for Indian Industries
    - 5.3.3 Initiatives under Microelectronics and Nanotechnology areas

- 5.4 Centre of Excellence
  - 5.4.1 Nanotechnology Centres
  - 5.4.2 Centre of Excellence on E-Waste Management
  - 5.4.3 CoE on Rechargeable Battery Technology (Pre-cell)
  - 5.4.4 Graphene Aurora
  - 5.4.5 Centre for Programmable Photonic Integrated Circuit and Systems (CPPICS)
  - 5.4.6 National Centre for Quantum Accelerator Chip using Lithium Niobate (NCQAC)
  - 5.4.7 National Strategy for Additive Manufacturing (NSAM)
  - 5.4.8 National Centre for Quantum Manufacturing Technology (NCQMT)
  - 5.4.9 MeitY-NSF: Machine Learning Guided 3D Printing of Self-Healing Sustainable Concrete from Waste Materials
  - 5.4.10 MeitY-NSF: Alloy Design and Processing Science for Additive Manufacturing of Rare Earth Permanent Magnets
  - 5.4.11 MeitY-NSF: Energy-Efficient Quantum Materials-Based Magnetic Tunnel Junctions for Unconventional Computing Applications
  - 5.4.12 CoE on products based on Li-ion (Post Cell)
  - 5.4.13 Centre of Excellence (CoE) in Intelligent Internet of Things (IIoT) Sensors
  - 5.4.14 India Innovation Centre for Graphene (IICG)
  - 5.4.15 Startups, Innovation, IPR and Entrepreneurship
  - 5.4.16 The Software Industry Promotion Division (SIPD) of MeitY
- 5.5 Societal Reach R&D
  - 5.5.1 Medical Tools, Equipments and Software

## 6. Internet Governance and Security of Cyber Space

171-194

- 6.1 Internet Governance Overview
- 6.2 National Internet Exchange of India (NIXI)
- 6.3 Security of Cyber Space
- 6.4 R&D initiatives under Cyber Security
- 6.5 Indian Computer Emergency Response Team (CERT-In)
- 6.6 Cyber Laws

## 7. Skill India: Capacity Building

195-206

- 7.1 Post Graduate and Doctorate Level
  - 7.1.1 Visvesvaraya PhD Scheme for Electronics & IT
- 7.2 Graduate level
  - 7.2.1 Scheme of Financial Assistance for setting up of Electronics and ICT Academies
- 7.3 Vocational Skill Development Level
  - 7.3.1 Two Schemes for Skill Development in the ESDM sector have been implemented
  - 7.3.2 Efforts to generate greater participation of Industry through Sector Skill Councils-Electronics, Telecom, IT/ITeS
- 7.4 Capacity Building in Niche Areas
  - 7.4.1 Information Security Education and Awareness (ISEA) Project Phase-III
  - 7.4.2 FutureSkills PRIME (Programme for Re-skilling/Up-skilling of IT Manpower for Employability)
  - 7.4.3 SwaYaan - Capacity building for human resource development in Unmanned Aircraft System (Drone and related Technology)
  - 7.4.4 Work-Based Learning Programme to Strengthen and Empower SC/ST/WOMEN/EWS Graduate Engineers through MeitY Institutions
  - 7.4.5 Empowering Police Personnel and Governance Officials of NE states through IT and Cyber Security Training
  - 7.4.6 Finishing School Program on 3D Printing & Additive Manufacturing Technology for Engineering Students of West Bengal and Bihar
  - 7.4.7 Chips to Startup (C2S) Programme
  - 7.4.8 Indian Nanoelectronics Users Program -idea to Innovation (INUP-i2i)
- 7.5 Establishment of Intelligent Educational Infrastructure (Smart) in Eklavya Model Residential Schools (EMRSs)
- 7.6 Grass-Root Level
  - 7.6.1 Create skill development facilities in deprived areas through the strengthening of the National Institute of Electronics and Information Technology (NIELIT)
  - 7.6.2 Capacity Building in IECT including training in Digital Skill sets and Current Industry Demanding Technologies for various sections of society in the NE States
- 7.7 IT for Masses Programme
- 7.8 E-Learning Platform
  - 7.8.1 Development of EdTech Platform in the Semiconductor Space to Democratize Chip Design and Development Ecosystem for the Masses

- 7.8.2 O Labs NextG (O Labs Next Generation)
- 7.8.3 MedSIM2.0 (Online Skills Lab and Virtual Patient Cases)

## **8. Statutory Organisation 207-218**

- 8.1 Controller of Certifying Authorities (CCA)
  - 8.1.1 Introduction
  - 8.1.2 Root Certifying Authority of India
  - 8.1.3 Services offered by Certifying Authorities
  - 8.1.4 Digital Locker Authority (DLA)
  - 8.1.5 Major Initiatives
  - 8.1.6 Workshops & Conferences
- 8.2 Unique Identification Authority of India (UIDAI)
  - 8.2.1 Introduction
  - 8.2.2 Relevance of Aadhaar number
  - 8.2.3 Aadhaar Act
  - 8.2.4 Features of Aadhaar number
  - 8.2.5 Enrolment
  - 8.2.6 Authentication
  - 8.2.7 Security measures
  - 8.2.8 Customer relationship management

## **9. Attached Offices and Societies 219-332**

- 9.1 Centre for Development of Advanced Computing (C-DAC)
- 9.2 Society for Applied Microwave Electronics Engineering and Research (SAMEER)
- 9.3 Centre for Materials for Electronics Technology (C-MET)
- 9.4 Education and Research Network (ERNET) India
- 9.5 National Informatics Centre (NIC)
- 9.6 National e-Governance Division (NeGD)
- 9.7 Standardization Testing and Quality Certification Directorate (STQC)
- 9.8 National Institute of Electronics and Information Technology (NIELIT)
- 9.9 Software Technology Parks of India (STPI)
- 9.10 Digital India Corporation (DIC)

## 10. Other Matters

333-346

- 10.1 Promotion of Hindi and implementation of the Official Language Policy
- 10.2 RTI Matters
- 10.3 Public Grievances
- 10.4 Citizens' Charter
- 10.5 Information & Documentation Centre (Library)
- 10.6 Parliament Section
- 10.7 Vigilance Unit
- 10.8 Gender Inclusive Initiatives

## Annexures

347-354

- I. Approval of Union Cabinet for extension of the Digital India Programme for the duration of 15<sup>th</sup> Finance Commission
- II. Summary of important Audit observations
- III. Employees structure as on 01.01.2026
- IV. List of Abbreviations

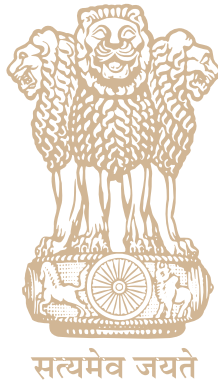

# Executive Summary

India has witnessed a transformative expansion of its digital economy over the past decade, driven by a series of strategic government initiatives that have reshaped governance, industry, and global engagement. This transformation has significantly strengthened India's position in electronics manufacturing, digital services, and global value chains. Indigenous manufacturing capabilities have expanded rapidly, supported by sustained investments in research and development that promote technological advancement, sustainability, and self-reliance. Alongside a growing emphasis on digital diplomacy and international partnerships, India is steadily emerging as a trusted global hub for electronics manufacturing and IT services, reinforcing its role within the global digital ecosystem.

Central to this transformation is the Digital India Programme, which has guided the nation towards a digitally empowered society and a knowledge-based economy. By expanding digital access, bridging the digital divide, and enabling inclusive service delivery, the programme has facilitated digital and financial inclusion at scale. At the core of these efforts lies India's Digital Public Infrastructure (DPI), which has played a pivotal role in democratising access to technology and public services while enhancing the efficiency, transparency, and responsiveness of governance.

Key DPI platforms have strengthened seamless and secure service delivery across sectors. Aadhaar, the world's largest digital identity programme, has enabled reliable authentication, with 142 entities adopting face authentication and over 319.82 crore authentication transactions recorded. DigiLocker has emerged as a cornerstone of paperless governance, with 62.10 crore registered users and more than 941.45 crore digital documents issued. UMANG has further enhanced ease of living by integrating e-Government services across central, state, and local bodies, serving over 9.97 crore registered users. Complementing these foundational platforms, and in recognition of India's linguistic diversity, the Ministry of Electronics and Information Technology (MeitY) is leveraging technology through Mission Digital India BHASHINI. This flagship initiative plays a critical role in bridging language barriers and expanding equitable access to digital services across India's multilingual population.

Building on this strong digital foundation, India has also emerged as the world's third-largest startup ecosystem, with over two lakh startups and more than 120 unicorns collectively valued at over USD 350 billion. The country hosts more than 35,000 technology startups, including over 3,500 deep-tech startups operating across emerging technology domains. Despite global economic headwinds, India's technology industry demonstrated resilience in FY 2024–25, with total revenue (including hardware) estimated at USD 283 billion, reflecting a year-on-year growth of 5.1 per cent. To ensure sustainable growth and enhance employability, initiatives such as FutureSkills PRIME have been implemented, with more than 16.66 lakh candidates enrolled and trained across diverse technology domains.

In parallel, India's electronics manufacturing sector has undergone a structural transformation, supported by targeted policy interventions and incentive schemes such as the Production Linked

Incentive (PLI) Scheme, the Semicon India Programme (SIP), the Scheme for Promotion of Manufacturing of Electronic Components and Semiconductors (SPECS), and Electronics Manufacturing Clusters (EMC 2.0). Further, Electronics Component Manufacturing Scheme (ECMS) was notified on 08th April 2025 to develop a robust electronics component manufacturing ecosystem in India. These measures have significantly strengthened domestic manufacturing capacity. As a result, the production of electronic goods increased from ₹6.41 lakh crore in FY 2021–22 to ₹11.32 lakh crore in FY 2024–25, registering a compound annual growth rate of 20.91 per cent. Electronics products now rank among India's top three export categories.

Within this broader manufacturing expansion, India has emerged as the world's second-largest manufacturer of mobile handsets by volume. To further consolidate its manufacturing ecosystem, the Government has taken decisive steps towards building a diversified, resilient, and sustainable semiconductor and display manufacturing landscape. A landmark milestone in India's semiconductor journey was achieved with the launch of the first "Made in India" chips from a pilot production line, laying the foundation for long-term self-reliance. Complementing domestic efforts, India has entered into Memoranda of Understanding (MoU) with key global partners, including the United States, Japan, the European Union, and Singapore, to strengthen resilient and diversified supply chains.

Alongside advances in hardware and manufacturing, India has made substantial progress in artificial intelligence by facilitating broad-based access to AI infrastructure and resources. High-end AI compute capacity has been expanded through infrastructure comprising over 38,000 GPUs, established in partnership with 14 cloud service providers. AIKosh, the national AI dataset platform, has onboarded 3,011 datasets and 243 AI models from 39 organisations across 20 sectors, including agriculture, health, governance, urban infrastructure, and the environment. The release of the India AI Governance Guidelines in November 2025 marked a significant step towards ensuring safe, responsible, and inclusive AI development. India is also set to host the AI Impact Summit, centred on the theme "*Welfare for All, Happiness of All*", with a focus on democratising AI and addressing the priorities of the Global South.

These advances are underpinned by the rapid expansion of digital infrastructure, particularly data centres, which have emerged as the backbone of India's digital economy. Their growth is being driven by widespread digitalisation across government and industry, increasing adoption of artificial intelligence, and growing reliance on cloud services. Supporting this expansion, the Government Infrastructure Cloud (GI Cloud – MeghRaj) has reinforced India's cloud ecosystem by enabling optimal utilisation of IT infrastructure and accelerating the deployment of e-Governance applications, including digital payments, identity verification, and consent-based data sharing. As India's digital capabilities deepen, the country has further positioned itself as a major hub for Global Capability Centres (GCCs), providing offshore business and technology services to multinational corporations.

Research and development continue to remain a cornerstone of India's digital sustainability strategy. Under national initiatives, 38 supercomputing systems have been deployed across premier institutions, including IISc, IITs, and national R&D laboratories, delivering a cumulative compute capacity of 48 petaflops (PF). In 2025 alone, four new systems were installed, three of which featuring indigenously designed "Rudra" high-performance computing servers and a locally developed HPC software stack, reinforcing India's self-reliance in advanced computing. MeitY has also established multiple Centres of Excellence (CoE) to scale indigenous technologies and bridge cutting-edge innovation with real-world challenges across sectors such as IoT, blockchain, healthcare, and agriculture.

Alongside technological advancement, MeitY has prioritised citizen rights and trust in the digital ecosystem. The notification of the Digital Personal Data Protection Rules, 2025 marked the full operationalisation of the Digital Personal Data Protection Act, 2023, establishing a robust, citizen-centric framework that balances individual rights with responsible data processing. Further, the act prioritises citizen's rights and promotes responsible data use by organisations. MeitY has also taken several measures for strengthening cyber resilience.

India's growing emphasis on digital diplomacy has further strengthened its global engagement in electronics and information technology. Under the leadership of MeitY, India actively participated in G20 Digital Economy Working Group deliberations, Artificial Intelligence Task Force discussions, and ministerial engagements in 2025, with a focus on universal digital inclusion, Digital Public Infrastructure, and equitable, trustworthy AI. Bilateral engagements, including discussions with South Africa, further reinforced cooperation in areas such as DPI, digital payments, artificial intelligence, startups, and digital skills.

Building human capital remains central to the sustainability of India's digital economy. Through initiatives such as the Indian Nanoelectronics Users Programme (INUP-i2i) and the Chips to Startup (C2S) Programme, MeitY continues to address skill gaps in electronics and IT. Over one lakh individuals have enrolled in chip design training, with approximately 67,000 trained to date. INUP-i2i has benefited over 8,589 researchers and students and facilitated the completion of 584 R&D projects nationwide. Additionally, the Visvesvaraya PhD Scheme has allocated 1,000 full-time and 153 part-time PhD seats under Phase II to strengthen advanced research in ESDM and IT/ITeS sectors.

MeitY is also advancing a comprehensive, gender-inclusive digital agenda by embedding women's empowerment across digital skilling, cybersecurity, artificial intelligence, startups, electronics manufacturing, and digital public platforms. Increasing participation of women across innovation, research, and entrepreneurship ecosystems reflects a growing shift towards inclusive leadership in the digital economy, particularly in rural and underserved regions.

The Annual Report 2025–26 of MeitY highlights the achievements of the Ministry and its institutions, including CCA, UIDAI, CERT-In, NIC, C-DAC, SAMEER, C-MET, NeGD, NIELIT, STPI, STQC, DIC, ERNET, and NIXI. The report underscores a sustained focus on citizen-centric digital governance, electronics manufacturing cybersecurity, Digital Public Infrastructure (DPI), emerging technologies, connectivity, skilling etc. Thus, collectively, these efforts have strengthened India's digital economy, empowered citizens, and fostered innovation, forming a robust foundation for realising the vision of Viksit Bharat 2047—a digitally empowered, inclusive, and self-reliant nation.



# 1

## CHAPTER

# Overview of MeitY

## Vision, Mission, Objectives, Structure and Functions of MeitY

### 1.1 Introduction:

Ministry of Electronics and Information Technology (MeitY) is responsible for formulation, implementation and review of national policies in the field of Information Technology, Electronics and Internet (all matters other than licensing of Internet Service Provider).

### 1.2 Vision:

e-Development of India as the engine for transition into a developed nation and an empowered society.

### 1.3 Mission:

To promote e-Governance for empowering citizens, promoting the inclusive and sustainable growth of the Electronics, IT and ITeS industries, enhancing India's role in Internet Governance, adopting a multipronged approach that includes development of human resources, promoting R&D and innovation, enhancing efficiency through digital services and ensuring a secure cyber space.

### 1.4 Objectives:

- **e-Government:** Providing e-infrastructure for delivery of e-services.
- **e-Industry:** Promotion of electronics hardware manufacturing and IT-ITeS industry.
- **e-Innovation/R&D:** Implementation of R&D Framework - Enabling creation of Innovation/ R&D Infrastructure in emerging areas of ICT&E/Establishment of mechanism for R&D translation.
- **e-Learning:** Providing support for development of e-Skills and Knowledge network.
- **e-Inclusion:** Promoting the use of ICT for more inclusive growth.
- **Cyber Security:** Securing India's cyber space.
- **Internet Governance:** Enhancing India's role in Global Platforms of Internet Governance.

### 1.5 Functions

1. Policy matters relating to Information Technology, Electronics and Internet (all matters other than licensing of Internet Service Provider).
2. Promotion of internet, IT and IT enabled services.
- 2A. Promotion of Digital Transactions excluding Digital Payments.
3. Assistance to other departments in the promotion of E-Governance, E-Commerce, E-Medicine, E- Infrastructure, etc.
4. Promotion of Information Technology education and Information Technology-based education.
5. Matters relating to Cyber Laws, administration of the Information Technology Act. 2000 (21 of 2000) and other IT related laws.

- 5A. Matters relating to online gaming.
- 5B. Matters relating to Cyber Security as assigned in the Information Technology Act, 2000 (21 of 2000) (as amended from time to time) and support to other Ministries / Departments on Cyber Security.
6. Matters relating to promotion and manufacturing of Semiconductor Devices in the country.
7. Interaction in IT related matters with international agencies and bodies e.g. Internet for Business Limited (IFB), Institute for Education in Information Society (IBI) and International Code Council – on line (ICC).
8. Initiative on bridging the Digital Divide: Matters relating to Digital India Corporation.
9. Promotion of Standardization, Testing and Quality in IT and standardization of procedure for IT application and Tasks.
10. Electronics Export and Computer Software Promotion Council (ESC).
11. National Informatics Centre (NIC).
12. Initiatives for development of Hardware/Software industry including knowledge– based enterprises, measures for promoting IT exports and competitiveness of the industry.
13. All matters relating to personnel under the control of the Ministry.
14. Unique Identification Authority of India (UIDAI).
15. Semi-Conductor Laboratory, Mohali.

## 1.6 WORK ALLOCATION

SNo.	Name & Designation	Work Allocation
1	Shri Akhil Kumar MD/CEO DIC	<ul style="list-style-type: none"> <li>• Designated Officer (u/s 69A)</li> <li>• Matters relating to India-AI Summit logistics</li> </ul>
2	Shri Abhishek Singh Additional Secretary, DG (NIC)	<ul style="list-style-type: none"> <li>• Artificial Intelligence, Emerging Technology, DIBD <b>[GC(KB)]</b></li> <li>• CEO India AI/ India AI Mission <b>[JS(SS)/GC(KB)]</b></li> </ul>
3	Shri Bhuvnesh Kumar CEO-UIDAI	<ul style="list-style-type: none"> <li>• CEO-NISG</li> </ul>
4	Shri Amitesh Kumar Sinha Additional Secretary	<ul style="list-style-type: none"> <li>• Personnel Division, Autonomous Bodies Coordination Division, General Administration Division and I&amp;DC [Library]</li> <li>• CEO, India Semiconductor Mission (ISM)</li> <li>• Matters related to SCL</li> <li>• Matters relating to R&amp;D in Electronics <b>[GC(SV)]</b></li> <li>• Matters related to CMET <b>[GC(SV)]</b></li> </ul>
5	Ms. Preeti Nath Economic Adviser	<ul style="list-style-type: none"> <li>• Digital Economy Division (DED)</li> <li>• HRD Division <b>[GC(TP)]</b></li> <li>• RajBhasha Section <b>[GC(TP)]</b></li> <li>• Matters related to NIELIT and ERNET <b>[GC(TP)]</b></li> <li>• Queries from Media <b>[GC(TP)]</b></li> <li>• Website and Social Media activities <b>[GC(TP)]</b></li> <li>• Gender Budgeting <b>[GC(TP)]</b></li> </ul>

SNo.	Name & Designation	Work Allocation
6	Shri Krishan Kumar Singh Joint Secretary	<ul style="list-style-type: none"> <li>Software Industry Promotion Division including DIIF</li> <li>Start Ups, Innovation, IPR and Entrepreneurship</li> <li>Matters related to STPI and MSH</li> <li>Cyber Security Division <b>[GC(SU)]</b></li> <li>Matters related to ICERT <b>[GC(SU)]</b></li> <li>CVO</li> </ul>
7	Shri Rajesh Singh JS & FA	<ul style="list-style-type: none"> <li>Integrated Finance Division (IFD)</li> </ul>
8	Shri Sushil Pal Joint Secretary	<ul style="list-style-type: none"> <li>Electronics Hardware (PLI)</li> <li>Semiconductors and matters related with India Semiconductor Mission</li> <li>Productivity &amp; Employment Generation</li> <li>Electronics Hardware (excluding PLI), CRO <b>[GC(AN)]</b></li> <li>Matters related to STQC and CCA <b>[GC(AN)]</b></li> <li>Internet Governance Division</li> <li>Matters related to NIXI</li> </ul>
9	Shri Ajit Kumar Joint Secretary	<ul style="list-style-type: none"> <li>International Cooperation Division</li> <li>Cyber Laws Division <b>[GC(DG)]</b></li> <li>Matters related to UIDAI <b>[GC(DG)]</b></li> <li>CEO MyGov</li> </ul>
10	Shri Nand Kumarum CEO-NeGD	<ul style="list-style-type: none"> <li>Digital Governance Division (DGD)</li> <li>Matters related to NIC, NICS, BISAG(N), DIC, NeGD, MyGov, CSC, NISG</li> </ul>
11	Shri Sudeep Shrivastava Joint Secretary	<ul style="list-style-type: none"> <li>Coordination Division (including SGoS)</li> <li>RTI, Grievances and Parliament Section</li> <li>R&amp;D in CC&amp;BT Division <b>[GC(MKJ)]</b></li> <li>R&amp;D in IT Division <b>[GC(MKJ)]</b></li> <li>Matters related to SAMEER and CDAC <b>[GC(MKJ)]</b></li> <li>India AI (Innovation Centre; Compute Capacity) <b>[through AS(AS)]</b></li> </ul>
12	Smt. Savita Utreja Scientist G & GC	<ul style="list-style-type: none"> <li>Cyber Security Division <b>[through JS(KKS)]</b></li> <li>Matters related to ICERT <b>[through JS(KKS)]</b></li> </ul>
13	Smt. Asha Nangia Scientist G & GC	<ul style="list-style-type: none"> <li>Electronics Hardware (excluding PLI), CRO <b>[through JS(SP)]</b></li> <li>Matters related to STQC and CCA <b>[through JS(SP)]</b></li> </ul>
14	Smt. Sunita Verma Scientist G & GC	<ul style="list-style-type: none"> <li>R&amp;D in Electronics Division <b>[through AS(AKS)]</b></li> <li>Matters related to NSM <b>[through AS(AKS)]</b></li> <li>Matters related to CMET <b>[through AS(AKS)]</b></li> </ul>
15	Smt. Kavita Bhatia Scientist G & GC	<ul style="list-style-type: none"> <li>Artificial Intelligence &amp; Emerging Technology <b>[through AS(AS)]</b></li> <li>India AI <b>[except 2 pillars assigned to JS(SS)] [through AS(AS)]</b></li> <li>Human Centred Computing (HCC) Division/DIBD <b>[through AS(AS)]</b></li> </ul>

SNo.	Name & Designation	Work Allocation
16	Shri Deepak Goel Scientist G & GC	<ul style="list-style-type: none"> <li>Cyber Laws Division <i>[through JS (Ajit Kr.)]</i></li> <li>Matters related to UIDAI <i>[through JS (Ajit Kr.)]</i></li> </ul>
17	Ms. Tulika Pandey Scientist G & GC	<ul style="list-style-type: none"> <li>HRD Division <i>[through EA]</i></li> <li>RajBhasha Section <i>[through EA]</i></li> <li>Matters related to NIELIT and ERNET <i>[through EA]</i></li> <li>Nodal Officer for responding to any queries/ clarifications sought in writing/through email by any media companies on any issues related to MeitY <i>[through EA]</i></li> <li>Website and Social Media activities <i>[through EA]</i></li> <li>Gender Budgeting <i>[through EA]</i></li> </ul>
18	Shri Manoj Kumar Jain Scientist G & GC	<ul style="list-style-type: none"> <li>R&amp;D in CC&amp;BT Division <i>[through JS(SS)]</i></li> <li>R&amp;D in IT Division <i>[through JS(SS)]</i></li> <li>Matters related to SAMEER and CDAC <i>[through JS(SS)]</i></li> </ul>

### 1.7 ORGANISATION STRUCTURE

The Secretariat of MeitY headed by Secretary is assisted by Financial Advisor, Group Coordinators and Heads of Organisations under the administrative control of MeitY. The organisation chart is as follows:-

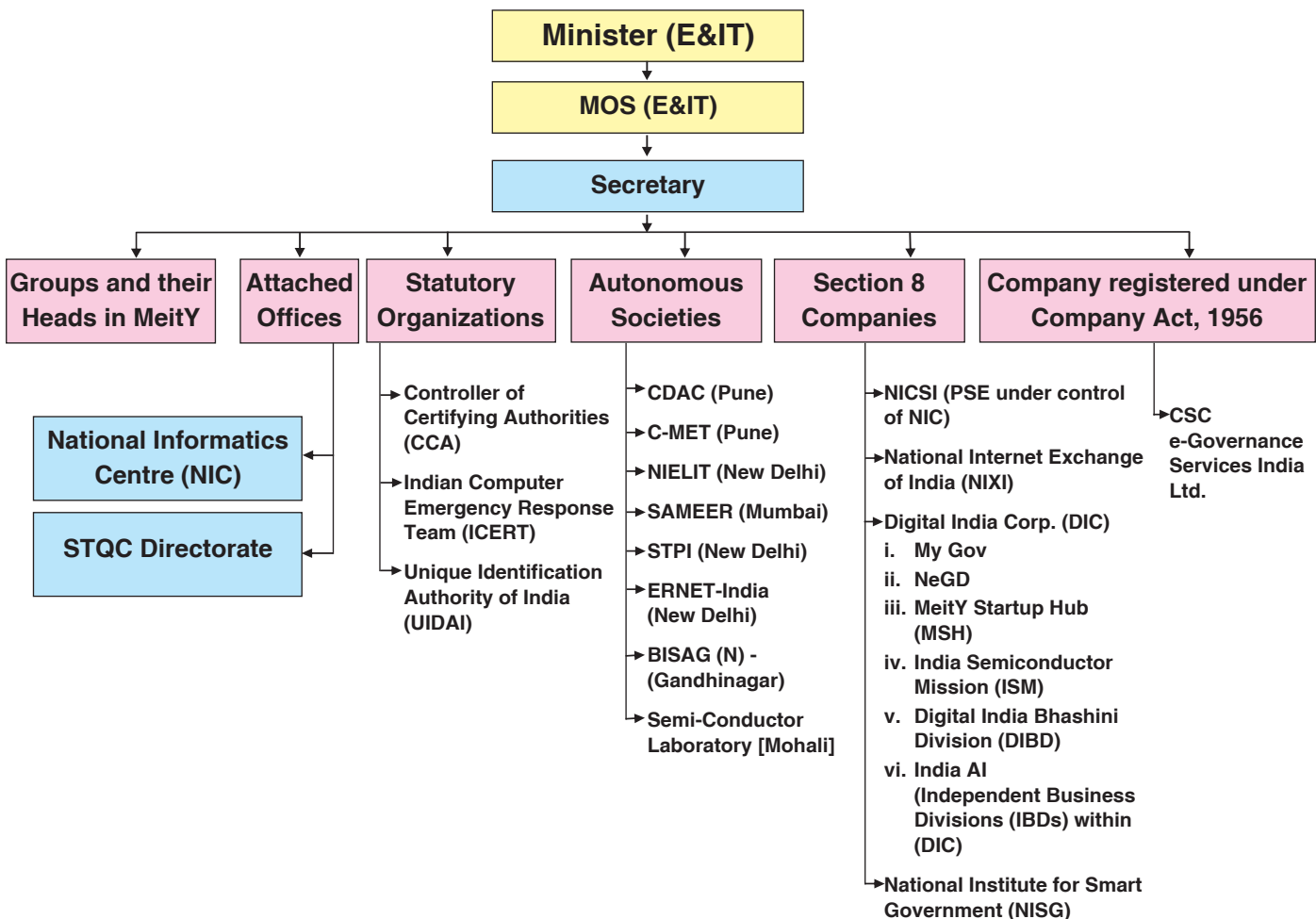

# 2

## CHAPTER

# Digital India

## Power to Empower

### 2.1 Introduction

Digital India, a flagship programme of the Government of India, aims to transform India into a digitally empowered society and knowledge economy. It weaves together a large number of ideas and thoughts into a single comprehensive vision so that each of them is seen as part of a larger goal. The focus of the Digital India Programme (DIP) is on being transformative to realize – IT (Indian Talent) + IT (Information Technology) = IT (India Tomorrow) and making technology central to enable change. This programme pulls together many existing schemes. The programme targets to provide digital services, digital access, bridge the digital divide, language divide and thereby, ensure digital inclusion, financial inclusion, and digital empowerment. The targets are sought to be achieved with the power of technology that is affordable, developmental, sustainable, and inclusive. The vision is centred on three key areas, namely Infrastructure as Utility to Every Citizen, Governance & Services on Demand and Digital Empowerment of Citizens.

#### 2.1.1 Extension of Digital India Programme

The Government, in August 2023, approved the extension of the 'DIP' with a total outlay of Rs. 14,903.25 Crore during the period of the 15<sup>th</sup> Finance Commission i.e., 2021-22 to 2025-26. The details are given at Annexure-I.

#### 2.1.2 Vision of Digital India

To transform India into a digitally empowered society and knowledge economy.

##### **Vision Area 1: Digital Infrastructure as a Utility to Every Citizen includes:**

- High-speed internet as a core utility
- Cradle to grave digital identity - unique, lifelong, online, authenticable
- Mobile phone & Bank account enabling participation in digital & financial space
- Easy access to a Common Service Centre
- Shareable private space on a public cloud
- Safe and secure Cyber-space

##### **Vision Area 2: Governance & Services on Demand includes:**

- Seamlessly integrated across departments or jurisdictions
- Services available in real-time from online & mobile platforms
- All citizen entitlements to be available on the cloud
- Services digitally transformed for improving Ease of Doing Business
- Making financial transactions electronic & cashless
- Leveraging GIS for decision support systems & development

**Vision Area 3: Digital Empowerment of Citizens includes:**

- Universal Digital Literacy
- Universally accessible digital resources
- All documents/ certificates to be available on the cloud

**2.2 Digital Infrastructure****2.2.1 Digital Identity****2.2.1.1 MeriPehchaan - National Single Sign On (NSSO)**

MeriPehchaan - National Single Sign On platform is a platform that authenticates citizens easily and securely. It aims at eliminating the need to repeatedly prove user identity to different applications and hold different credentials for each application. It is an extensive collaboration of the three mainstream SSO platforms e-Pramaan, Jan Parichay and DigiLocker. MeriPehchaan enables standardized registration which means users need to provide information once for accessing different services. MeriPehchaan authenticates the user based on multiple authentication parameters like username, mobile number, Aadhaar, PAN, etc.

Currently, NSSO caters to more than 15,089 services and has completed more than 200 crore transactions. Key services include Rajasthan SSO, Assam Sewasetu, Digishakti, COWIN, DigiLocker, eShram, Mizoram DICT, Service Plus, Assam EoDB portal, Ladakh eSeva, Gatishakti New Master Plan, CRIS, mSevanam, MyGov, S3Waas, Bihar State Services, ISRO, Jansugam, MP Single Sign On, Kerala Excise etc.

**2.2.1.2 e-Hastakshara: An Online Digital Signing Facility (C-DAC's e-Sign Service)**

As a flagship initiative within the Government's Digital India program, C-DAC has introduced e-Hastakshar, a cutting-edge eSign service that allows citizens to digitally sign documents online in real-time, providing a legally acceptable form and convenient alternative to physical signatures. Over the past year, C-DAC integrated this service with various departments, ministries, and agencies at the Central and State Government levels, as well as Union Territories. eSign service and Aadhaar service are now accessible through the portal for status tracking and monitoring purposes. In addition, eSign service notifications have been implemented via our WhatsApp Business account to ensure that organizations receive timely updates regarding the service. Currently, more than 300 agencies are utilizing the eSign service. Since its inception, over 34.56 crore e-Sign digital signatures have been issued by C-DAC.

**2.2.2 Enhancement of National Informatics Centre (NIC) National Cloud Services**

National Informatics Centre (NIC) has been providing Data Centre/ Cloud services to the Government at Central and State level to ensure Government services internally and for citizens. Under NIC cloud services, virtual servers have been allocated for various e-Governance applications to Ministries/ users and over 5000 websites of the Government are being served through NIC cloud. For rapid deployment of new services and to strengthen the existing capacities and services, the cloud capacities of the national cloud has been enhanced by government funding as well as by public private partnership.

**The project has the following key features**

- Cloud Infrastructure Capacity: The compute infrastructure has been considerably enhanced by more than 1.6 Lakhs vCPUs and additional Block/ Unified/ Object/ Software defined raw storage of over 37 Petabytes.
- Cloud Management solution: National cloud platform offers IaaS and PaaS services through a self-serving portal. The new cloud management platform has introduced various automations thereby reducing manual intervention

and increasing user satisfaction. Key features of the platform are:

- ✓ Multi- location Cloud Capabilities
- ✓ Unified User Management
- ✓ Security Management
- ✓ Application Life Cycle Management
- ✓ Unified Observability and Service Assurance to Support Autoscaling
- ✓ Unified Metering, Billing & Cost Management
- Improvement in Cyber Security Posture: It would help NIC to manage various cybersecurity aspects of the cloud infrastructure.
- Workshop/Training of Cloud Services: Workshops/ trainings of core teams of Government Ministries/ Departments which enables the users for utilization/ managing and monitoring of cloud services.

### 2.2.3 National Data Centre in North-East Region (NDC-NER)

To strengthen the digital transformation and service delivery in the North-Eastern Region, Ministry of Electronics and IT has approved the project for setting up of “National Data Centre in North-East Region (NDC-NER)” at Guwahati, Assam on 19<sup>th</sup> September 2020. This project is in line with “Vision Document for Digital North-East by 2020”. This Project is being implemented by National Informatics Centre (NIC) through NICS.

#### The NDC-NER is proposed with the following key features

- NDC-NER building with Ground plus 5 floors with a facility of 200 racks (G+3) for Data Centre and Cloud infrastructure (IT and Non-IT). 4th and 5th floor shall be built and reserved for future expansion.
- It would provide a robust, highly available & significantly scalable infrastructure with adequate redundancy to enable Government to render efficient delivery of citizen services.
- It will have Security Operation Centre (SOC), Network Operation Centre (NOC) and Centre of Excellence (CoE) for Application Security. It will act as Disaster Recovery site for various applications hosted in other Data Centre in the region.
- It will act as Disaster Recovery site for various applications hosted in other data centres in the region.

### 2.2.4. GI Cloud (MeghRaj)

To deliver ICT services over Cloud to all the Ministries/Departments at Centre/State/UTs level and utilize the benefits of Cloud computing, Government of India has initiated an ambitious initiative- “GI Cloud”, also named as ‘MeghRaj’. It is designed to promote the use of Cloud technology to enhance the efficiency, scalability, and cost-effectiveness of IT services within the Government. The vision of this initiative is to accelerate delivery of e-Services in the country, while optimizing ICT spending of the Government.

This will ensure optimum utilization of the infrastructure and speed up the development and deployment of eGov applications. The architectural vision of GI Cloud encompasses a set of discrete cloud computing environments spread across multiple locations, built on existing or new (augmented) infrastructure, following a set of common protocols, guidelines and standards issued by the Government of India.

#### Major benefits of GI Cloud

- On demand scalability of infrastructure to meet the long-term capacity requirements and elasticity to cater to the peak load requirements. The major components of MeghRaj include:

- Setting up of State and National Clouds.
- Empanelment of Cloud Service Providers.
- Setting up of Cloud Management Office (Policies, Guidelines, templates, security norms, certification, etc.).
- Awareness workshops, training programmes and migration support for cloud adoption by Departments.
- Setting up of Clouds by other Government entities.
- Rapid development, deployment, and re-use of ICT applications.
- Enable conversion of CAPEX to OPEX paving the way for consumption based billing and faster procurement of IT Infrastructure services.

### Achievements

The first National Cloud implemented by NIC is already being used by more than 2,188 Government Departments and the total number of virtual servers running on NIC Cloud is 32,205.

NIC Cloud can be accessed using the following link: <https://cloud.gov.in/>.

### Initiatives under Digital India Program hosted on National Cloud include

- Digital India Portal
- Digital Locker
- Make-in-India
- Skill Development
- Smart Cities
- Online Registration System (e-Hospital)
- Aadhaar based Biometric Attendance of Government employees
- Jeevan Pramaan - service for pensioners
- MyGov - largest citizen engagement platform of the Government

MeitY has empanelled 26 Cloud Service Providers for a variety of Cloud deployment models (Public Cloud, Virtual Private Cloud, and Government Community Cloud) and Cloud Services (IaaS, & PaaS). The status of the audit and the contact details of the empanelled CSPs can be assessed using the link: <https://ambud.meity.gov.in/>.

## 2.2.5 Bhaskaracharya National Institute for Space Applications and Geo-informatics (BISAG-N)

BISAG-N is an autonomous scientific society under the Ministry of Electronics and IT continues to serve as a national centre of excellence in satellite communication, geospatial technologies, software development and emerging technology-based decision support systems. Established originally as RESECO in 1997 and elevated to a national institute in 2020, BISAG-N has evolved into a multidisciplinary organisation supporting governance, planning, monitoring, and capacity building across 50+ Union Ministries, 28 States and 8 Union Territories.

During Financial Year 2025-26 BISAG-N has significantly expanded its technical capabilities, institutional partnerships and nationwide impact through scalable platforms, national digital systems, and high-quality SATCOM services.

### 2.2.5.1 Satellite Communication (SATCOM): National Education & Capacity Building Backbone

BISAG-N operates one of the largest SATCOM infrastructures in the country with 12 state-of-the-art studios (10 in Gandhinagar and 2 in New Delhi) and uplink teleports capable of handling 350+ DTH channels. These facilities are

extensively used for education, skill development, training, digital literacy, agriculture extension and administrative capacity building.

### Key Achievements

- Continued 24×7 transmission of 200 PM e-Vidya channels under the One Class One Channel initiative, supporting multilingual school education nationwide.
- Support for 48 SWAYAM Prabha Higher Education channels with daily refreshed content from IITs, UGC, IGNOU and other premier bodies.
- Broadcasting services for DigiShala, KITE VICTERS (Kerala), VANDE Gujarat, SATHEE (MoE Competitive Exam Guidance) and SAEN (MEA).
- Expanded international collaboration through MEA for DTH-based educational services to neighbouring countries.
- Enhanced content development workflows for subtitles, translation, animation and interactive educational content.

BISAG-N's SATCOM functions are aligned with the Hon'ble Prime Minister's vision for leveraging distance education to democratize learning and ensure nationwide access to high-quality educational resources.

### 2.2.5.2 Geo-spatial Technologies & National Digital Platforms

BISAG-N continued to lead large-scale development and implementation of geospatial and emerging-technology-based decision support systems. Over 500+ national applications and 2000+ datasets have been integrated into multiple governance platforms.

#### PM GatiShakti National Master Plan

BISAG-N is the core technology partner for the design, development and continuous enhancement of the national PM GatiShakti platform under DPIIT. During 2025-26:

- Advanced features for infrastructure planning, multimodal logistics, forecasting, and approvals have been implemented.
- State Master Plans for all States/UTs and District Master Plans for all districts were developed/updated with thematic layers and planning tools.
- Integration support was provided for 27+ Ministries and 36 States/UTs for data standardization and real-time coordination.

#### Sectoral Decision Support Systems

Major platforms developed and operationalised:

- Call Before u Dig (CBuD) – For safe excavation and underground utility protection (DoT).
- AITS for EPFO – Automated accident information processing for timely claim settlements.
- PM-DAKSH – Skill development and employment enablement for PwDs and marginalized communities.
- NGDR Portal – National Geo-science Data Repository (GSI) for mineral exploration using GeoAI.
- PM-UDAY – Property rights regularization for Delhi's unauthorized colonies.
- PM Internship Portal (MCA) – End-to-end management of work-experience internships; over 50 lakh applications processed monthly.
- PM JANMAN – Geo-spatial decision support for Particularly Vulnerable Tribal Groups (PVTGs), mapping 34,000+ new habitats.

- Haj Suvridha App – Digital facilitation for Haj pilgrims with emergency response features.
- Amrit Sarovar – Generation and monitoring of 75 water bodies per district using geo-analytics.
- Jal Jeevan Mission GIS Portal – Geotagging of rural water supply pipelines with 20+ API integrations.
- NESIDS/PM-DevINE MIS (MDoNER) – Real-time project monitoring for North Eastern Region.
- Urja Suraksha Samanvay (DGH) – Real-time monitoring of E&P assets across India's EEZ.
- Civil Aviation Portal – Site suitability and obstacle analysis for airstrips and airport planning.
- WARIMS (Ministry of Jal Shakti) – Integrated hydrological DSS for flood forecasting, reservoir operations and water resources accounting.
- Coal Sector GIS Platform – Spatial intelligence for coal blocks and inter-ministerial coordination.
- Gujarat State NOC Portal – 50-department single window regulatory clearance system.
- Kisan Khidmat Ghar (J&K) – Farmer-centric service delivery and agriculture extension.
- Samadhan (J&K) – Unified grievance redressal for citizens.
- ICDS GIS Portal (Gujarat) – Real-time management of Anganwadi infrastructure.
- SVAMITVA GIS Integration – Drone-based rural property validation.

### 2.2.5.3 Research, Emerging Technologies & Software Development

BISAG-N has institutionalized rapid development using modern technology stacks including Java, Python, React, NodeJS, GeoServer, QGIS, Microservices and mobile frameworks. Key focus areas include:

- GeoAI and predictive analytics
- Quantum computing research
- IoT-based monitoring systems
- Big Data processing for national datasets
- End-to-end cloud architecture for national platforms

Systems are developed with a bottom-to-top approach ensuring inclusiveness, accuracy and field-level validation.

### 2.2.5.4 Cyber Security, Testing & Standardization

BISAG-N maintains robust security and quality assurance frameworks:

- ISO 9001, ISO 27001, ISO 19115, ISO 19157 certified
- CMMI Level 5 compliant processes
- Dedicated cyber-security and testing labs for application hardening, vulnerability assessment and quality audits
- Alignment with national standards for data governance, GIS metadata, and remote sensing data quality

### 2.2.5.5 Capacity Building, Outreach & SATCOM-Enabled Training

BISAG-N played a pivotal role in enhancing digital capacity across government sectors through:

- Continuous SATCOM-based capacity building programmes
- Finishing School and Internship programmes for youth and students
- Collaboration with educational institutes nationwide

- Training on GIS, remote sensing, PM GatiShakti, emerging technologies and project implementation workflows
- These initiatives ensure widespread adoption of developed systems and operational readiness across departments.

### 2.2.5.6 Infrastructure, Governance & Institutional Strengthening

During 2025-26, BISAG-N has strengthened infrastructure across Gandhinagar and New Delhi through:

- Expansion of studios, control rooms and satellite uplink facilities
- Development of new labs and research units
- Establishment of multiple coordination offices in New Delhi for faster engagement with central ministries

Sustainability is ensured through value-based culture, affordable solutions, rapid execution, capacity building and long-term institutional partnerships.

In 2025-26, BISAG-N has emerged as a critical national digital infrastructure partner for governance, planning, service delivery and education. By integrating geospatial technologies, satellite communication, AI/ML, data analytics and emerging technologies, BISAG-N continues to empower Ministries, States and UTs in achieving digital transformation and accelerating socio-economic development across the nation.

## 2.3 Mobile based online Governance and Services on Demand

### 2.3.1 India Portal

India Portal serves as a *single-window access point* to information and services that are electronically delivered by various Government departments, institutions, and organisations across India. It is one of the most popular sources of authentic information for a wide range of stakeholders — including citizens, government entities, businesses, and the Indian diaspora.

Acting as a gateway to Government websites at the Central, State, and District levels, the portal is developed using modern technologies and features a contemporary design with an intuitive, user-friendly interface, easy navigation, and a well-structured information architecture. It supports multiple Indian languages and ensures accessibility for all users, including persons with disabilities.

Built on a secure, scalable, and cloud-based microservices architecture, the portal ensures high reliability and performance. It is integrated with 11 major platforms — including myScheme, MyGov, S3WaaS, OGD Platform, India Code, iGOD, NeVA, Digital Sansad, PIB, DD News, and News On AIR — to provide comprehensive information across various sectors.

The India Portal receives over 3.6 million visitors per month, generating approximately 8.0 million page views, and has a registered user base of over 10.78 lakh. To date, the portal has published around 27,100 metadata records.

In addition to serving as an information gateway, the India Portal also acts as a platform for the promotion and dissemination of various Government initiatives and events such as:

- Micro site for Republic Day showcasing the Republic Day celebrations, President's speech to the nation and awardees of various awards that has been designed, developed, and maintained at <https://knowindia.india.gov.in/republic-day-celebration/index.php>
- Micro site for Independence Day which is maintained at <https://knowindia.india.gov.in/independence-day-celebration/index.php>
- Spotlights covering important Government initiatives and events like National Task Force, PM-PRANAM (PM Programme for Restoration, Awareness Generation, Nourishment, and Amelioration of Mother Earth), Senior

Citizens Welfare Portal, Pradhan Mantri Uchcharat Shiksha Abhiyan (PM-USHA), Electronics Component Manufacturing Scheme, Prime Minister's Young Authors Mentorship Scheme (YUVA 3.0) Scheme.

- Monthly newsletters that are sent to subscribers of India Portal to keep them updated about the latest content on the portal. The portal also has a Social Media presence through Facebook page (<https://www.facebook.com/nationalportalofindia>) and Twitter handle (<https://twitter.com/indiagovin>).

Other initiatives/activities under the aegis of India Portal are given in the figure below:

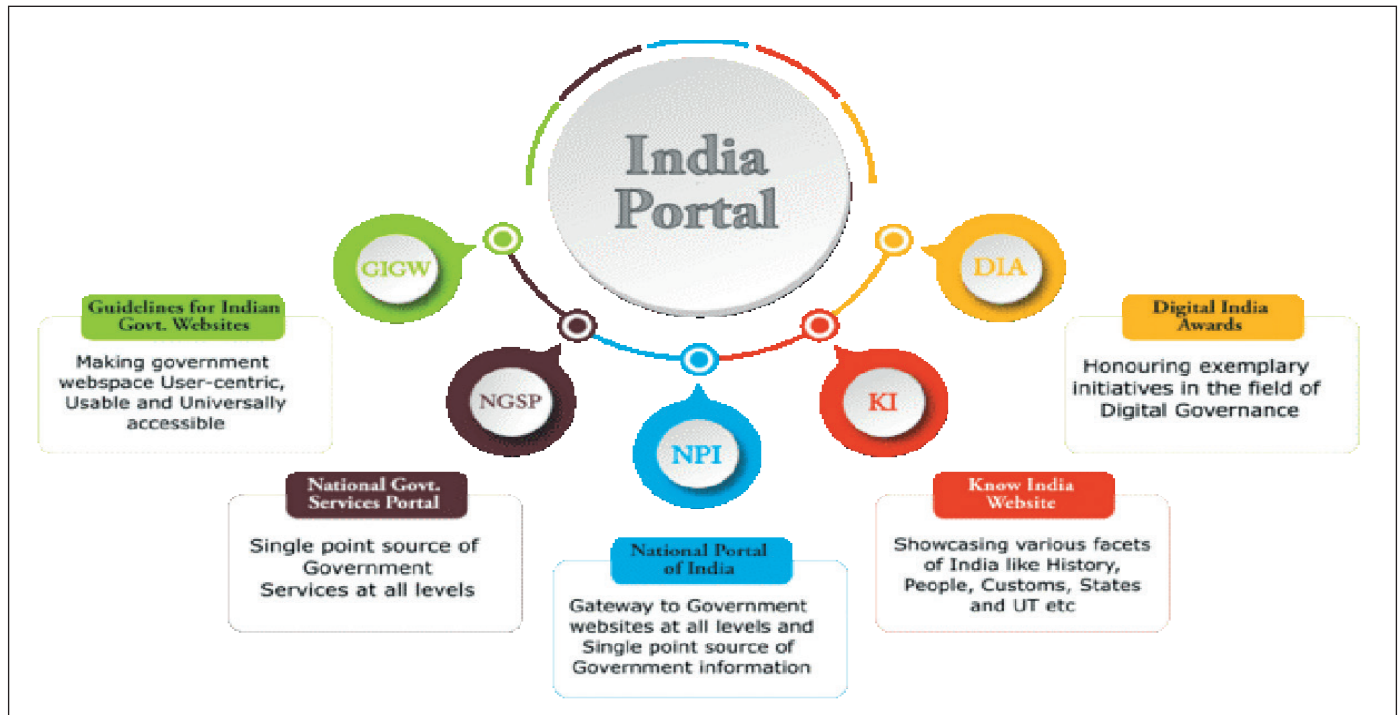

### 2.3.2 User experience for Government (Websites & Apps) UI/UX 4G

To adapt best practices by government Departments in UI/UX (User Interface/User experience) a project named as "User Experience for Government Websites & Apps (UX4G)" also known as UI/UX4G was launched and it is mainly focussed to examine GIGW compliance of Government websites/ apps, to identify areas of improvement in UI/UX, create a framework and guidelines to help Government Departments to adopt better UI/UX, develop libraries of GIGW compliant ready to use, reusable Web Components, sensitize them and extend necessary technical hand-holding support on use of web components for improving the quality of UI/UX.

#### Project Objectives:

- Act as an enabler and facilitator in developing a framework and guidelines for user centric experience on Government Websites & Mobile Apps, especially the UI/UX for ease of use.
- Provide ready to use web components, tools, solutions, technical support, etc. for Government Departments so that they can provide best user experience.
- Enable Government Departments to improve their quality-of-service delivery through citizens' feedback.
- Enable Government Departments to conduct any kind of surveys for better planning.
- Build capacities within Government for better UI/UX and Design thinking in order to improve ease of access and navigation of Government websites and Apps.

### Achievements:

- Improved and developed the design interface for 380+ (80+ Mobile Apps and 300+ Websites) applications of Govt. Departments have been onboarded for Central and State Governments.
- Framework creation and Guidelines prepared for Government Departments to adopt better UI/UX.
- To focus on identified pain areas and improve services accordingly, Government services have been integrated to collect citizen feedback. This initiative has provided a department centric advanced analytical report with service improvement indicator so that department can focus on those areas.
- Government departments has been sensitized and necessary technical hand holding support been extended on the use of web-components.
- For better UI/UX and design aspects of Government websites/apps various training programs, workshops and hackathon has been conducted in the field of UI/UX for Government departments. So far, 85+ workshops have been conducted online under the UX Capacity building program and 6200+ participants have attended these workshops.
- Repository to use design templates prepared for Government Ministries/ Departments at Centre & State level. These design templates are compliant with Government guidelines & e-Gov Standards.
- Design System 2.0 is live on the UX4G website.
- Audit 360 Tool is live on UX4G website helping product team in automated UX audit of government websites.
- Library development of GIGW compliance.
- Design of UI/UX to improve the quality of Govt. websites and apps.

### 2.3.3 DigiLocker: Revolutionizing Paperless Governance

In the continued pursuit of building a paperless and digitally empowered governance ecosystem, DigiLocker has reinforced its position as India's leading platform for secure issuance, verification, and storage of digital documents and certificates.

#### Key Achievements

DigiLocker achieved a significant milestone by recording 62.90 crore registered users. Over 941.45 crore digital documents were made available by 2,347 issuers.

#### Growing Partnerships

- Onboarded multiple high-impact national and State-level integrations during 2025-26, demonstrating DigiLocker's scalability, reliability, and cross-sector relevance.
- Integrated the Passport Seva Programme, enabling digital access to Passport Verification Records and significantly streamlining citizen verification processes.
- Enabled Central Armed Police Forces (CAPFs) digitization through CRPF, facilitating issuance of digital identity cards for over 3 lakh personnel.
- Enabled Jan Aadhaar (Rajasthan) integration, providing digital access to Jan Aadhaar Cards covering 7.95 crore citizen records.
- Onboarded key national regulatory bodies, including NSDL, CDSL, CMPFO, and the National Database of Arms Licenses (MHA), enabling verified access to financial, pension, and license records.
- Successfully integrated 19 State Accountant General (AG) Offices under the CAG framework for digital issuance of pension-related documents. Enabled Controller General of Communication Accounts (CGCA), DoT integration,

providing digital access to e-PPO (3.50 lakh), GPO (1.30 lakh), CPO (1.30 lakh), and Form-16 (1.50 lakh) documents. Integrated Directorates of Treasuries and Accounts of Maharashtra, Chhattisgarh, and Uttar Pradesh for e-PPO, GPO, CPO, and GPF services, benefiting pensioners and government employees.

- Expanded State Family Register integrations, with Samagra ID (Madhya Pradesh) and Him Parivaar (Himachal Pradesh) benefiting over 9.75 crore citizens, while integrations with other States are in progress.
- Further, added numerous digital services across States for their digital documents through e-District services integration across Maharashtra, Chhattisgarh, Assam, Meghalaya, and Himachal Pradesh; Andhra Pradesh State Services integration; Kerala State Energy Department services, digitizing over 2.3 crore records through Electricity Consumer Certificates and Solar Feasibility Certificates; Urban Local Bodies (ULBs) services integration in Surat Municipal Corporation, Dombivli Municipal Corporation, and Uttar Pradesh ULB platforms.

### **EntityLocker: Empowering Institutions and Organisations**

To extend the benefits of paperless governance to the institutional domain, DigiLocker launched Entity Locker — a dedicated digital locker for organizations, institutions, and government entities. Entity Locker enables departments, corporations, universities, banks, and statutory bodies to securely store, issue, and verify organizational documents digitally, ensuring authenticity, accountability, and operational efficiency.

It has emerged as a foundational component for e-Governance workflows, empowering government bodies and regulated entities to transition towards trusted digital repositories that comply with national standards of authentication and auditability.

#### **Key Achievements:**

- As of 31<sup>st</sup> December, 2025, Entity Locker has onboarded 40,739 entities and 374 issuers, marking a transformative step in institutional document management.
- Achieved Entity Locker integration with Indian Railway e-Procurement System (IREPS), marking one of the earliest requestor-side implementations.
- Integrated the National Single Window System (NSWS) with Entity Locker, enabling digital document exchange across 26 Ministries and 35 Departments.
- Continued integration with CAG and State AG Offices for electronic pension orders, GPF statements, and audit certificates, reinforcing institutional adoption of DigiLocker for administrative record management.

These integrations collectively signify DigiLocker's evolution into a national digital backbone for trusted document exchange, verification, and interoperability — empowering both citizens and organizations to operate seamlessly in a secure, paperless digital environment.

### **2.3.4 Electronic Transaction Aggregation and Analysis Layer 3.0 (eTaal 3.0)**

#### **Introduction**

As part of the Government of India's initiative to promote transparency, security and accountability across all facets of governance, many Central and State Government Ministries/Departments/Organizations (MDOs) have transitioned to a digital-first approach by facilitating and recording eTransactions for a digital-first approach to government services.

The eTaal portal (<https://etaal.gov.in>) was developed to provide a near real-time view of eServices, aggregating eTransaction counts from integrated applications via web API technology. Launched in April 2022, eTaal 3.0 aims to measure qualitative aspects of eService delivery, enabling performance comparisons across Central Ministries, States, Union Territories, and Smart Cities, down to the district level. It also incorporates AI-enabled chatbots, predictive analysis, and Business Intelligence (BI) dashboards for generating meaningful insights.

## Achievements

- 4,292 eServices have been integrated since the launch of the eTaal portal.
- 1,007 eServices integrated with granularity up to district level.
- As of 31<sup>st</sup> December 2025, a total of 1,35,711 crore eTransactions have been recorded.
- Currently, a total of 95.04 crore eTransactions are being recorded on a daily basis.
- Users can access 15+ types of analytical reports on the eTaal 3.0 website.
- Qualified eServices on a 9-parameter Key Performing Indicator (KPI) framework. Each eService is evaluated and scored on parameters such as Use of Digital Signatures, ePayment integration, Implementation of Mobile Application, Local Language Interface, Application Security Audit, Accessibility etc.

## Benefits

The eTaal portal provides several key benefits for enhancing e-Governance services:

- **Near Real-time Monitoring:** Offers near real-time tracking of eTransactions, ensuring up-to-date data on service delivery.
- **eService Transaction Benchmarking:** Allows for qualitative and quantitative eService Transaction comparisons across Central Ministries, States and Union Territories.
- **Transparency and Accountability:** Aggregates data from multiple applications, promoting transparency in government services and consolidation of data in one single platform.
- **Advanced Analytics:** Features include AI-enabled chatbot, predictive analysis, and Business Intelligence (BI) dashboards for generating actionable insights.
- **Comprehensive Reporting:** Provides a unified view of all eServices and a variety of reports such as timeline analysis, transactions per 1000 population, State services reporting and more.

### 2.3.5 Vikaspedia 2.0

Vikaspedia is a MeitY initiative to promote an AI-augmented digital ecosystem to leapfrog the availability and accessibility of digital information in Indian languages, thereby empowering citizens and driving digital transformation. Through collaboration with diverse stakeholders, Vikaspedia harnesses technology, capacities, and knowledge enablers to efficiently create and disseminate e-information, fostering a dynamic digital environment.

The revamped technology framework of Vikaspedia ([www.vikaspedia.in](http://www.vikaspedia.in)) catalyzes multi-sectoral, multilingual and multimodal collaborative knowledge sharing and access by citizens and development stakeholders. The platform is enriched with AI enabled features such as Machine Assisted Translation (supporting 20 Indian languages), Automatic Speech Recognition (supporting 10 Indian languages), Summarize content, Assisted content drafting, Optical Character Recognition, multilingual and voice enabled chatbot, context aware search, knowledge graphs, etc.

The vibrant community of Vikaspedia includes 6.5 lakh+ collaborators (individuals and institutions) networked as 229 Digital Communities of Practice. The Communities have co-created and shared 9 million+ multilingual knowledge resources covering key livelihood sectors such as agriculture and allied sectors, health and nutrition, energy and environment, education, social welfare, women, financial education, digital governance, etc. 41 Master Trainers workshops were organized during the period for first level services providers across the country. Focussed outreach campaigns on thematic areas were taken up through various ICT modes covering 2.1 crore population across 10 states of North and North eastern region and Aspirational districts.

### 2.3.6 Implementation of National Data Highway (NDH)/ API Setu

MeitY in 2015 had notified the 'Policy on Open Application Programming Interfaces (APIs)'. The policy intended to promote efficient sharing of data among data owners and inter-and-intra Governmental agencies to achieve the objective of interoperable systems in order to deliver services in an integrated manner. The key objective of this project is to facilitate implementation of Open API Policy and build open and interoperable digital platforms to enable seamless service delivery across government. Under the project, a platform namely, 'API Setu' has been developed.

#### Achievements:

- Number of published APIs: 7850, More than 609.85 crore transactions
- Number of publishers: 2468+ (Key publishers: PAN, Driving License, Registration of Vehicles, COVID Vaccination Certificate, CBSE etc.)
- Number of Consumers: 6150+ (Key consumers: eSanad, NABARD, Centre for e-Governance, Karnataka, Department of Higher Education, Haryana etc.)

#### Notable use cases of the platform:

- University of Delhi uses API Setu to check the academic credentials of CBSE students applying to the University on real time basis.
- Karnataka State Police utilize API Setu to check candidates' class X and XII marks while applying for a job. With this step, the overall recruiting period has been cut in half.
- e-Sanad is an application of Ministry of External Affairs used to verify the educational qualifications of students asking for admission to overseas universities.
- Registrar General of India's Death certificate verification service is being used by various Central and State Govt Departments to verify certificates received at their side.

### 2.3.7 Pragati VC 2.0

PRAGATI is a unique integrating and interactive platform through which Hon'ble Prime Minister monitors the implementation of various government schemes, grievances, state and central related projects & programs, by directly interacting with all stake holders like Secretaries to Government of India and Chief Secretaries of States on single platform through Videoconferencing. This program has proved effective in addressing and resolving issues by bringing down the inter-departmental communication gap and thus minimizing the time taken for implementation of projects and schemes.

The PRAGATI 2.0 was approved with an outlay of Rs. 47.09 Cr for the 5 years. The project outlay for PRAGATI VC 2.0 was enhanced from Rs. 47.09 Cr. To Rs. 49.09 Cr., and the project duration extended up to 31st March 2026 for continuing to support the essential ongoing operations. This is the PM's unique initiative for resolving bottlenecks in project implementation, cutting delays, reviewing the progress of flagship government initiatives, keeping tabs on handling & resolution of public grievances.

Using the PRAGATI video conferencing infrastructure Government of India has reviewed 377 (Central/States) Projects worth around Rs 85 Lakhs crores. Hon'ble Prime Minister has chaired 50 PRAGATI videoconferencing sessions till date.

Since 2014, 377 projects have been reviewed under PRAGATI Platform, and across these projects, 2,958 out of 3,162 identified issues - i.e. around 94 percent - have been resolved, significantly reducing delays, cost overruns and coordination failures.

In the 50th meeting, PM reviewed five critical infrastructure projects spanning five states with a cumulative cost of more than ₹ 40,000 crore.

### Major Achievement

Other virtual meetings, apart from PRAGATI VC meetings during last 5 years

S. No.	Other virtual meetings	No. of Conferences
1	VC meetings chaired by Hon'ble Prime Minister other than Pragati VC	1115
2	VC Meetings chaired by PMO officials	1229
3	Cabinet Secretary	1009
4	Secretaries of Government of India	8736
5	Chief Secretaries of States	11238
	<b>Total</b>	<b>23327</b>

### Flagship VC sessions

S. No.	Flagship VC sessions	No. of Conferences
1	Viksit Bharat	17
2	Flagging off Trains and Metros	34
3	Rozgaar Melas	16
4	Launching & Inauguration of Projects	38
5	<b>Major International videoconferencing sessions:</b> <ul style="list-style-type: none"> <li>• G-20 Summit related</li> <li>• VoGSS - Voice of Global South Summit</li> <li>• International Conference on Creating Global Perspective rooted in Local Values for Sustainability, The 9th International Adolescent Summit with GACC China, International Year of Millets – 2023, Startup India International Summit, Toycathon 2021, Quad etc.</li> </ul>	65
	<b>Total</b>	<b>157</b>

### 2.3.8 myScheme:

To meet Universal Transparent Tracking of Applications and Responses to Applications (UTTARA) project's objective of developing an online platform for schemes search and discovery, myScheme - a product for advanced and personalised search for eligible schemes was launched by Hon'ble PM on 4th July, 2022 during Digital India Week-2022 in Gandhinagar. myScheme is a National Platform that aims to offer one-stop search and discovery of the Government schemes. The platform helps the citizens to find the right Government schemes for them. It also guides on how to apply for different Government schemes. The portal may be accessed at <https://www.myscheme.gov.in/> and mobile App may be downloaded from <https://play.google.com/store/apps/details?id=in.gov.negd.myscheme>

The prominent features of myScheme are given as under:

#### Features available for Beneficiaries:

- **Personalized Scheme Search:** Citizens can search and discover Government schemes, for which they may be eligible based on their demographic details.

- **Comprehensive Scheme Information:** Each scheme includes detailed sections such as Description, Eligibility, Benefits, Application Process, Documents Required, Frequently Asked Questions (FAQs), and Updates.
- **Check Eligibility Questionnaire:** Users can verify eligibility for schemes through a simple Yes/No-based questionnaire.
- **Artificial Intelligence (AI)-Powered Chatbot:** Enhancing user interaction by simplifying scheme search through conversational assistance.
- **Multilingual Access to Scheme Details:** The platform offers scheme content in 15 Indian languages including English, enabling every citizen to access and understand the information easily.
- **Categorized Scheme Listing:** Schemes are available across 15 different categories, enabling easier discovery for users.
- **Bookmark Schemes:** Users can bookmark their favourite schemes for quick access at a later stage.
- **Profile Management:** Users can save profiles for themselves or their relatives to simplify and speed up the scheme search process.
- **Mobile and Multi-Platform Availability:** Available on Unified Mobile Application for New-age Governance (UMANG) app/web, integrated with DigiLocker and MeriPehchaan Single Sign-On (SSO) for secure login/authentication.

#### Features available for Government Officials:

- User management – role-based permissions/rights to the officials of the respective departments may be granted.
- Provision to add scheme-wise news and updates.
- User Sign-in & Sign-up via Parichay.
- Real-time Notifications service to send real-time updates via email and in-app notifications.

#### Achievements:

- So far, there are a total of 4,500+ schemes published out of which Central government schemes are 550+ whereas State/UT government schemes are 3950+. There are approximately 3700+ schemes of which the Check Eligibility Questionnaire is updated on the myScheme platform.
- An AI-powered chatbot has been integrated to enhance scheme search and discovery through conversational interaction.
- Over 400 Government of Uttarakhand schemes have been published on the myScheme platform with active support from State officials, and the platform was officially inaugurated in the State on 10.12.2025 by the Hon'ble Chief Minister.

### 2.3.9 Gov.in Secure Intranet Portal

A state-of-the-art platform 'Gov.in Secure Intranet' platform is developed by National Informatics Centre (NIC) under the guidance of MeitY to streamline all day to day operations of government Ministry/Department/Organization (MDO) officials. This robust platform offers a unified Single Sign On (SSO) through Parichay to provide access to Government to Employee (G2E) applications such as eMail, eOffice, Sparrow, Prayas among others.

Executive Dashboard provides bird eye view to senior officers about the status of grievances, court cases, VIP references, Media coverage, RTI Application etc. pertaining to respective Ministry.

With advanced UI/UX inspired by global best practices, the platform facilitates efficient Calendar Management & Task Tracking, all accessible via desktop or mobile application. The platform's meeting scheduling tools and multi-platform

integration, including Swagatam integration for visitor passes and options for virtual meetings across various platforms like BharatVC etc. ensure seamless coordination and communication.

**At A Glance**

<p><b>10</b> Central Government Ministries onboarded</p>	<p><b>9K+</b> Users onboarded on the platform</p>	<p><b>88%</b> reduction in time to schedule a meeting</p>	<p><b>500+</b> Parichay applications integrated</p>
<p><b>Single Sign-on access to:</b></p> <ul style="list-style-type: none"> <li> eMail</li> <li> eOffice</li> <li> PRAYAS</li> <li> SPARROW</li> <li> eHRMS and more...</li> </ul>	<p><b>Key Modules:</b></p> <ul style="list-style-type: none"> <li> Engagement Scheduler</li> <li> Task Management</li> <li> Correspondence Management</li> <li> Goal Tracker</li> <li> Document Management</li> </ul>	<p><b>AI-enabled features:</b></p> <ul style="list-style-type: none"> <li> Meeting Transcription</li> <li> Automated MoM generation</li> <li> Document summarization</li> <li> Content-based search in images</li> <li> Phonetic search</li> </ul>	

**Features**

Following is the list of features that the application offers:

- Feature reach engagement management capable of sending eMail meeting invite Notification and reminder through SMS and SANDES.
- Automatic generation of virtual meeting link by select any of the meeting platforms amongst BharatVC, Google Meet, Webex, and Metaverse Platforms
- Automatic generation of Visitor Pass of Swagatam for external participants of the meeting
- Calendar syncing with other calendar application is also available.
- Automatic MoM generation with digital signature
- API based Integrated applications: Bhashini, Collab Files, GovDrive, eSamikSha, eOffice etc. have been integrated through API.
- AI powered features such as GovAI Meeting Assistant, Virtual Meeting Transcription and Summarization, Phonetics search, PDF & Image Content search, Word Cloud etc.
- The Application is accessible through desktop, mobile (iOS and Android), wearable device.

**API Integrations**

<p><b>Govt. Tools</b></p> <ul style="list-style-type: none"> <li> Parichay</li> <li> GovDrive</li> <li> Bhashini API</li> <li> Collabfiles</li> <li> AI chatbot</li> <li> Swagatam</li> </ul>	<p><b>Meeting Platforms</b></p> <ul style="list-style-type: none"> <li> BharatVC</li> <li> Webex</li> <li> CDOTmeet</li> <li> Google Meet</li> <li> MS Teams*</li> <li> Zoho Meeting*</li> </ul>	<p><b>Executive Dashboard</b></p> <ul style="list-style-type: none"> <li> PIB</li> <li> CPGRAMS</li> <li> iGOT</li> <li> LIMBS</li> </ul> <hr/> <p><b>Calendar Sync</b></p> <ul style="list-style-type: none"> <li> Google Calendar sync</li> <li> Outlook calendar sync</li> </ul>
---	--	---

\* Integration in process

### 2.3.10 Prayas 2.0

PRAYAS – “Dashboard of Dashboards” (<https://prayas.nic.in>) pursuing excellence in governance has been developed under the direction of the PMO with collaborative efforts of Data Analytics Informatics Division, NIC and Centre of Excellence for Data Analytics (CEDA), NICS I to present a comprehensive and consolidated view of schemes of various Ministries/Departments in one single platform for improved monitoring and decision-making.

This platform offers interactive visualizations, robust analytics, and actionable insights to support data-driven governance, ensuring alignment between policymaking and program implementation. Prayas integrates data electronically via APIs directly from the MIS/IT systems of the concerned Ministries and Departments. The platform was demonstrated to the Hon’ble Prime Minister on September 4, 2020, and subsequently to all Union Cabinet Ministers and Ministers of State during October-November 2021.

#### Major Achievements of the Project:

- 1240 KPIs have been onboarded over the platform along with 192 schemes.
- 100 DBT Schemes have been onboarded the portal.
- 3000+ visualizations have been displayed over the platform.
- Modification has been conducted in geo-granularity and periodicity of data. A total of 53 schemes in periodicity whereas 51 schemes in terms of granularity have been modified/optimised.
- Deployment of an AI-based chatbot enables direct queries into the system.

### 2.3.11 Bharat Data Exchange (Bharat X)

- The Bharat Data Exchange Platform is the next phase of the Open Government Data (OGD) 2.0 initiative. The platform is designed to establish, manage, and sustain a national-scale, sector-agnostic unified data exchange solution. The platform aims to ensure administrative, legal, and technical compliance by implementing robust data governance mechanisms
- As on 31.12.2025, OGD India has 4,21,045 dataset/resources, 12,604 catalogs, 3,623 Visualizations created, and 2,36,312 Application Programming Interfaces (APIs) created. OGD India has 43.88 million times viewed and 11.42 million times datasets have been downloaded. All these datasets are updated with their respective granularity. Some of these datasets are updated multiple times a day in real time e.g., Real time Air Quality Index (AQI), eShram, PINCODE, Rainfall, Aadhaar Enrolment and Update, Patent, Kisan Call Center, Current Daily Price of Various Commodities from Various Markets (Mandi), etc.
- Many training sessions were organized for CDOs/Data Contributors. A workshop on “Accelerating Innovation through Data Sharing” was organized on OGD platform ([data.gov.in](http://data.gov.in)) in Guwahati, Assam for Northeastern States. It aimed to enable and encourage data sharing by Northeastern States on [data.gov.in](http://data.gov.in) platform.

#### Major Achievements of the Project:

- Facilitated seamless data exchange between Government and Private stakeholders, supporting G2G, G2X, and X2X use cases in compliance with legal frameworks.
- Successfully implemented Data Access Models enabling granular, field-level access control to datasets by data providers.
- Introduced dynamic digital agreements for secure and efficient data sharing, ensuring compliance, traceability, and access to allied artifacts.
- Developed a secure and trusted environment for data exchange, incorporating Open, Registered, and Restricted Access models to suit varying data sensitivity levels.

- Enforced open metadata standards, integrating domain-specific metadata schemes to promote interoperability, discoverability, and enhanced usability of datasets

### 2.3.12 eGovernance Standards & Guidelines

Standards form an important pillar in 'Digital India'. 'Standards in e-Governance' is a high priority activity, which ensures sharing of information and seamless interoperability of data across e-Governance applications. MeitY had set-up an institutional mechanism under Digital India program to evolve/ adopt standards in e-Governance under the project titled e-Governance Standards and Guidelines (eGSG). Key objective of this project is to develop / adopt ICT standards, guidelines and/or frameworks for effective and efficient implementation of e-Governance projects.

C-DAC, Pune and Standardisation Testing and Quality Certification (STQC) Directorate have been entrusted to develop/ review ICT standards, guidelines and/or frameworks for e-Governance projects along with proliferation of MeitY notified standards and guidelines so far.

#### Achievements:

The major achievements this year include:

- Out of 15 standards/guidelines /framework, 6 guidelines namely IndEA 2.0, Cloud Inter-operability/Portability, Anonymization of Data (AoD), Metadata and Data Standards (MDDS) of Education, Metadata and Data Standards of Logistics, Internet of Things (IoT) Security have been approved/ notified.
- 3 guidelines on topics namely Mobile Security Guidelines (MSG), Guidelines for Zero Trust Architecture (ZTA), Enterprise Architecture (EA) Security were submitted to BIS are likely to be published/ notified.
- Closed Group meeting conducted for draft guideline Two Factor and Multifactor Authentication (2FA/MFA) and 2 draft guidelines namely Sandbox Testing and OLES are submitted for Closed Group Review.
- Further, 4 draft guidelines namely Microservices, Enterprise Risk Management, MDDS Agriculture and Interoperability Framework for e-Governance (IFEG) (revision) are likely to be ready for Closed Group Review.
- 29 State-level sensitization workshops and 01 academic awareness workshop have been conducted on already notified standards/ guidelines/ frameworks.

### 2.3.13 Unified Mobile Application for New-Age Governance (UMANG)

#### Overview:

UMANG has been launched with an objective to improve ease-of-living by putting the power in the hands of citizens for availing major government services anytime, anywhere with just few clicks on a single unified mobile application integrated with DigiLocker, myScheme, NSSO, etc.

It enables the citizens of India to access e-Government services of various sectors such as Agriculture, Education, Health, Housing, Employees, Pensioners, Students, Ration Card, Railways, and many more services from the Central and State Governments.

UMANG is available in 23 multi-lingual languages (for top 100 services), including English & Hindi.

#### Achievements:

- Till 31<sup>st</sup> December 2025, UMANG has about 2390 – Central and State Govt. services (including 855 DBT services) from 240 departments of Central and State Government of 29 States/UTs and many more are continuously being on-boarded.
- Over 9.97 Crore users are registered and benefiting from services on UMANG.

- Around 2.71 Crore Claims in EPFO have been raised via UMANG Platform between January to December 2025.
- UMANG app, migrated completely on MeriPehchaan – National Single Sign-On for login, can now be accessed more securely. Voice-based search was implemented to enhance the user experience.
- Bank of India (BOI) app is now integrated on UMANG portal and users having account in the same bank can access the banking services.
- Some of the major departments like e-Saras, NPCI, Poshan Tracker, MP e-Nagar Palika have been onboarded during the period.
- UMANG's International version is helping Indian international students, NRIs and Indian tourists abroad, to avail Government of India services, anytime. It is also helping in taking India to the world through 'Indian Culture' services available on UMANG and create interest amongst foreign tourists to visit India.
- UMANG app services are also made available in assisted mode through Common Service Centres (CSCs) and 13 private partners to extend the reach to the users

### 2.3.14 Virtual Reality-Based Assistive System for Learning and Assessment of Persons with Intellectual Disabilities (Divyang SARTHI)

The Virtual Reality-based Assistive System for Learning and Assessment of Persons with Intellectual Disabilities specifically designed for persons with intellectual disabilities and their support networks. Key objective of the project is to develop a framework and content for the identified topics in the area of intellectual disability including Down syndrome, Fragile X syndrome, ADHD, Autism, Cerebral palsy, and developmental delays. This is a comprehensive framework that enriches the assessment cultivates innovative teaching methods, promotes meaningful learning experiences, and empowers evaluation procedures specifically for individuals with intellectual disabilities.

This project will integrate various curricula across the country in the area of intellectual disability to incorporate the list of the subjects, concepts, and topics to be taught for the holistic development of persons with intellectual disabilities. The project made significant progress, transitioning from framework design to large-scale content development and testing. The project has received wide appreciation from experts, educators, and parent organizations for the quality, inclusivity, and scientific depth of the content developed so far, marking an important step toward creating an accessible digital learning ecosystem for persons with intellectual disabilities.

The platform 'Divyang Sarthi' has been developed and beta version of the platform (<https://divyangsarthi.in/>) has been launched on December 08, 2025. This innovative solution will benefit persons with intellectual disabilities, as well as their parents, educators, and experts, by enabling greater participation and providing adaptable learning experiences. It will help them learn various activities for day-to-day life with the assistance of parents and professionals.

#### Achievements:

- Learning content: A total of 2,226 topics/sub-topics/task, and tasks have been developed, additionally 1,500 in Hindi language under the 'Activities of Daily Living', 'Domestic', 'Functional Academics' domains.
- Major stakeholders on-boarded as on date:
  - ✓ Institutions: 163; Professionals: 216,
  - ✓ Parents: 24,483 and Students: 26,896
- Brainstorming and Content Validation Workshops: A total of 110 brainstorming and content validation workshops were conducted since the inception of the project to finalize topics, sub-topics, and teaching strategies, and to validate the developed content.

- Capacity Building and Awareness Workshops
  - ✓ A total of 122 awareness, presentation, and capacity-building sessions were organized in hybrid mode, including two zonal workshops, to strengthen outreach and stakeholder engagement across India.
  - ✓ National-level consultations such as the National Parents Meet (Kolkata, February 2025 & Lucknow, November 2025), MANTHAN Workshop (Hyderabad, June 2025), and expert meetings at NIMHANS and SNEH Nagda provided valuable feedback on content design, therapeutic alignment, and inclusivity.
  - ✓ The Governor of Karnataka, Shri Thawar Chand Gehlot, felicitated the project during the Annual Meet of the Self Advocates Forum of India (Nagda, July 2025) for its outstanding contribution to inclusive education and innovative use of technology for persons with intellectual disabilities.

### 2.3.15 CollabFiles (<https://collabfiles.gov.in>)

The objective of the project is to provide a centralized platform for Government officials and employees to create and manage office documentation such as documents, spreadsheets etc. To facilitate portability of documents in standard formats such as xml, txt, docx, xlsx, odt etc.

#### Achievements:

As on September 2025, there are 38000+ users, working on 62000+ files. 189+ Department including Department of Telecom, Census of India, Railway Board, Director General Defence Estates, Enforcement Directorate, Ministry of Home Affairs, Delhi Metro Rail Corporation, National Institute of Rural Development, Directorate of Mines & Geology, Govt of Telangana, Central Power Research Institute, NIC etc

### 2.3.16 GovDrive – Storage as a Service (<https://drive.gov.in>)

The objective of the project was to provide Storage as a Service for the Government of India via cloud-based multi-tenant platform to Government officials for sharing documents. To provide a document storage and synchronization service for Government officials through GovDrive application. The project aims to deploy a service that includes user agents for all devices and will enable Government officials to store, share, access, delete and /or modify the documents /files /folders online.

#### Achievements:

- As on September 2025, the platform is running to store documents and/or folders securely for current user base of 21 lakh catering functionalities like uploading/downloading single and multiple files/directories, creating/sharing/moving/copying/replacing folder/directory, deleting/restoring files/folders, external platform integration with CollabFiles and ZoHo, edit/rename file/folder, mark file/folder as favorite, comprehensive search of files/folders/emails and mail preview.
- Desktop client and mobile application have been developed and deployed.

### 2.3.17 Kisan Sarathi 2.0: Enhancement, Operations Maintenance and Support

The objective of the project is to provide multi lingual support to farmers in seeking the advisories in the domains of agriculture, horticulture, fishery and animal husbandry directly from the Agricultural Scientists. Kisan Sarathi 2.0 an integrated national ICT platform caters to agriculture extension related activities and services. The platform provides seamless, multi-channel (audio-video consultation, App, IVR, Chatbot, Portal, Whatsapp, email, etc.) support to farmers to connect with the knowledge base & pool of large number the subject matter experts spread across all 730+ KVKs and 100+ ICAR institutions in all the States and UTs. Development/Customization of multi-lingual, multi-media ICT platform for supporting multi-ways communications among farmers, researchers, extension personnel etc is also undertaken.

Development of Agriculture Advisory Management System (AAMS) to support the Agricultural Experts and ultimately farmers and integration with Kisan Sarathi 2.0. Establishment of a framework for seamless operation and maintenance is also taken up.

**Achievements:**

- Integration with Kisan Call Center (1800-180-1551) has been completed, with pilot testing initiated in West Bengal and Uttar Pradesh.
- Integration of Common Service Centers (CSC) in Kisan Sarathi 1.0 was done. Now for Kisan Sarathi 2.0, it is in progress, enabling expanded farmer identification, registration, and query handling.
- Farmer App, Expert App, Farmer Mobile App, Expert Mobile App is under development.
- 2.78 Crore Farmer registered onto Kisan Sarathi Portal
- 741+ KVKs on boarded onto Kisan Sarathi Portal
- 3076+ Experts registered.

## 2.4 Digital Empowerment

### 2.4.1 Collaboration Application Development Platform by opening the Source Code of Government Applications (Open Forge)

OpenForge (<https://openforge.gov.in>) is a collaboration platform similar to Github that provides industry standard tools and features for version control, release management, code repository, requirements/bugs trackers and document repository. It is the Government of India's platform for the open collaborative development of e-Governance applications. This platform provides strategic control to government departments over their software source code. In 2015, MeitY rolled out the "Policy on Collaborative Application Development by Opening the source code of Government Applications" which provides a framework for archiving government custom-developed source code in repositories and opening these repositories for promoting reuse, sharing and remixing.

**Project Objectives:**

- Provide a platform for maintaining code repositories and version control for government source code.
- Promote a culture of open collaborative application development between public agencies and private organizations, citizens and institutions.
- Reduce development cycles and fasten the rollout of e-governance applications in the country.
- Deliver e-governance services and solutions of higher quality and security through increased transparency and mass peer review.
- Reduce e-governance project cost and bring down total cost of ownership through a system of reuse, remixing and sharing.

**Achievements:**

- Currently, OpenForge has 17,877 registered users.
- So far, 4,028 projects have been onboarded.
- Till now 13,71,467 GIT push has been made.
- Many projects of national importance such as CoWIN, Poshan Tracker, GeM, UMANG, DigiLocker, Smart City, API Setu, iGOT Karamyogi, Ayushman Bharat CPHC-NCD, etc are on this platform for day-to-day development activities.

## 2.4.2 National Knowledge Network (NKN)

National Knowledge Network (NKN) is an innovative, cutting-edge, robust, and secured network, which provides a centralized multi-gigabit high-speed digital connectivity backbone for research & educational institutions and Government Organisations spread across India.

NKN was approved in March 2010 by Cabinet Committee of Infrastructure (CCI) to be implemented by National Informatics Centre (NIC) over a period of 10 years at a total outlay of ₹ 5,990 Crore, which has been enhanced to ₹ 7188 Crore. Subsequently, duration of NKN has been extended year-on-year with the current extension being till 31<sup>st</sup> March, 2026. The approval for the next phase of NKN [i.e. National Knowledge Network Phase II] is under process.

NKN is the only network globally, that carries R&E, Internet, and e-Governance traffic as three independent verticals under one umbrella.

### NKN Impact on e-Governance

NKN has been empowering Digital India, as it is the primary backbone for all e-Governance initiatives in the country.

NKN has been playing a vital role in enhancing digital capabilities and implementing the digital initiatives of the Government of India. NKN addressed the challenging task of providing a robust and secured network which enabled the government to implement Government to Government (G2G) and Government to Citizen (G2C) services seamlessly and in time bound manner for implementing the services.

### NKN Status: National Reach (as of December 2025)

- Under NKN, 1869 links have been extended to institutions, comprising almost all the major IITs, Central Universities, State Universities, NITs, IIITs, IIMs, hospitals in tertiary care such as AIIMS, PGIs, State Government hospitals, national laboratories under DAE & DST, DRDO, MHRD, ICAR, ICMR and a host of other government institutions / departments.
- The outreach includes 681 district links under NKN covering 560 districts across India
- Today NKN has 31 Points of Presence (PoPs) in various State Capitals (including 7 Super Core PoPs)
- The network strength of NKN comprises of high speed (10G) core backbone with uniformly spread 99 core links across the country comprising of 91 core links with 10G bandwidth, 6 core links with 2.5G bandwidth and 1 core link with 1G bandwidth.
- In its progressive outreach, NKN has provided 10G bandwidth to 89 Edge links covering 68 Institutes, 1G bandwidth to 1017 Edge links covering 992 Institutes and 100M bandwidth to 750 Edge links covering 749 Institutes.
- The network has a peak traffic flow of 26 Petabytes and average traffic flow of 2.1 Tera Bytes in a day.

### NKN Status: International Reach

- NKN has been significantly expanding its global reach by establishing 3 International PoPs at Singapore, Amsterdam, and Geneva (CERN).
- For increasing its Global outreach, NKN has peered with other National Research and Education Networks (NRENs), which includes: Asi@connect in Asia Pacific, CERN and GEANT in Europe, SingAREN in Singapore, Internet2 in USA, LEARN in Sri Lanka, BdREN in Bangladesh, and NORDUnet for Nordic countries.
- NKN has established direct links with Singapore (1X10 Gbps), Netherlands-Amsterdam (2X10 Gbps), Switzerland-Geneva (2X10 Gbps) and extended NKN connectivity to Sri Lanka (1X1 Gbps).
- As per the vision of Hon'ble Prime Minister of India, to bolster sub-regional collaboration among SAARC and BIMSTEC countries, NKN has already expanded its connectivity to Sri Lanka.

## Achievements

### Facilitating Digital India

NKN facilitates Digital India, as it is the backbone for all e-Governance initiatives in the country. In addition to educational Institutions, NKN connects 4 NDCs (National Data Centres), 32 SDCs (State Data Centres), 30 SWANs (State-wide Area Networks), Ministries, Departments, and mission-oriented agencies such as S&T, DRDO, Earth Sciences, Space, ICAR, MHRD, amongst others.

### Connecting Remote Locations

- Connectivity in North-eastern region: NKN has ensured stable connectivity in the north-eastern region by connecting major institutions and enabling digital inclusion in the region.
- VSAT Connectivity in remote locations: NKN has successfully established a high capacity SCPC VSAT connectivity at Kavaratti, Lakshadweep and Port Blair, Andaman & Nicobar Islands.
- Connectivity in Jammu & Kashmir (J&K) and Ladakh: NKN has extended connectivity to some of the major institutions of J&K and Ladakh such as IIT Jammu, IIM Jammu, University of Jammu, Sher E Kashmir, Defence Institute of High-Altitude Research (DIHAR) Leh, etc.
- Submarine connectivity: Established a link of capacity 1 Gbps through BSNL to Andaman & Nicobar Islands.

### Savings & Benefits

Savings due to NKN Network Topology

- **Virtual Private Network:** Savings due multiple CUGs of VPNs connection on network
- **Innovative Techniques:** Peering and Caching with TSPs & Leading Content Providers
- Savings via NKN negotiated rates with TSPs & based Bandwidth Usage of Institutes
- **Unified Network:** Aggregation of network leading to high-cost effectiveness
- **High Bandwidth:** High Speed Dedicated Network to multiple Real Time synchronization projects
- **24x7 Security:** 24x7 Dedicated Security Operations Centre (SOC), Network Operations Centre (NOC), Threat Monitoring Services Team

### Secure Network

NKN's security eco-system is balanced, robust and provides a secure backbone network for its user community that can recover quickly from breakdowns and other cyber-attacks.

- NKN has completed Information Security certification of ISO 27001:2022 for 19 of its Core PoP locations.
- Vulnerability Assessment and safeguarding of the network is performed regularly via multiple tools, e.g., DDOS Implementation, etc.
- For time synchronisation, NKN has implemented Network Time Protocol (NTP) which is an Internet time synchronisation protocol used to synchronise computer clocks to a time reference using the IP network / internet.
- NKN currently provides multiple free of cost services to the Institutes like Single Sign On (SSO), DDOS, DNS, LDAP, etc.

### Role in assisting Digital Health endeavours

Numerous esteemed institutions across the country, including CSIR-Lucknow, NIV-Pune, ICAR-Hyderabad, Army R&R Hospital-Delhi, STQC, CDAC, DRDO, and others, have acknowledged and commended NKN's efforts in delivering

uninterrupted services and support during the lockdowns in the country.

Throughout the pandemic, NKN diligently maintained round-the-clock services for the National Data Centre (NDCs), which host critical national applications such as MyGov, the Prime Minister's Official Website, Government Websites, e-Office, e-Hospital, and more. The significance of NKN's role in supporting the secure communication platform of NIC Email services within the government, running on the NKN Network, has grown even more pronounced.

On the global stage, NKN's connections with Global NRENs (National Research and Education Networks) have enabled domestic institutions to transcend their physical boundaries, fostering higher academic and research pursuits. NKN ensured seamless connectivity for all linked International NRENs, ensuring no disruptions in connectivity. NKN also extends its network to SAARC countries, offering a plethora of services without interruption. Even amid the pandemic, numerous collaborations with Global Research & Development Networks have continued to flourish.

### NKN as a Backbone is Building Resilience in Higher Education

Institutes have fully utilized NKN Network in creating a virtual eLearning platform as a contemporary way of working

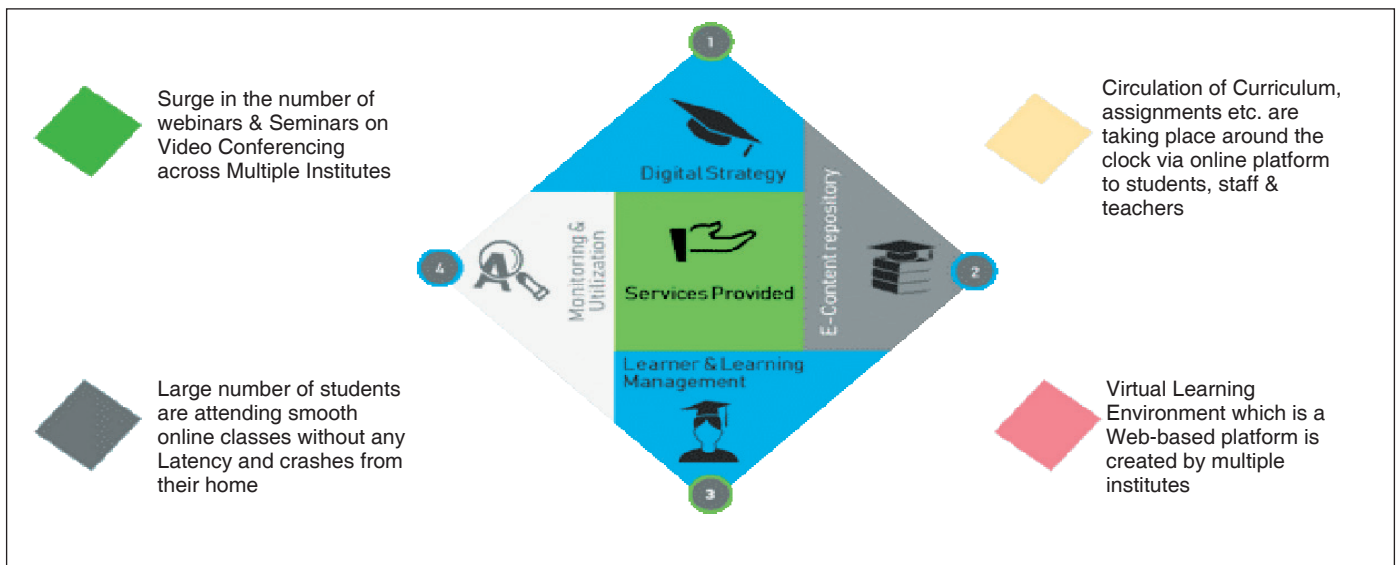

### ROLE IN CHANDRAYAAN-3

NKN's connectivity has played a vital role in transmission of Real-time data from Tower Transmission Centre (TTC) stations- ISDN Bylalu to the satellite control centre. This was critical as this was mission critical for transferring Chandrayan-3's data in real-time. NKN had supported the Chandrayan-3 through following modes:

- **LVM3-M4 Launch Vehicle:** NKN backbone is being used for the launch vehicle VPN (VRF) for trajectory tracking via ISTRAC ground stations. NKN launch vehicle VPN provided connectivity between ISTRAC and SHAR for higher bandwidth connectivity.
- **NKN VRF for satellite tracking:** NKN VRF or satellite tracking provides reliable connectivity with 7 ISRO establishments for critical operation of the satellite. During the landing of the satellite, ESA (European Space Agency) station and ISTRAC Bylalu Deep Space Network provided crucial data. In both the sections, NKN-GEANT and NKN-IRS-VRF provided support.
- **SPACE-VPN:** It is a Closed User Group (CUG) formed for the ISRO Institutes to collaborate on space exploration activities with high-speed data transfer with low latency for enabling missions like Chandrayan-3, where it served as a platform on which the complete event was exclusively webcasted across the ISRO's centres.

## High Quality Network

To ensure high accessibility, availability & sustainability, NKN has focused on dedicated high bandwidth with low latency and redundancy.

- In order to optimise bandwidth utilization, NKN has brought the content close to the users, via direct peering and caching with leading Content Providers such as Google, Microsoft, Facebook, and Akamai.
- The peering has been done via servers installed at the premises of NKN in order to ensure enhanced user experience. With the aid of NKN, Near Real Time Data availability is provided along with service continuity and high uptime.
- NKN provides direct connectivity to Institutes / Organizations by taking the best path via minimum hops. Hence, connected Institutes have given NKN a rating of excellent on all quality-of-service parameters.

### 2.4.3 Integrated Citizen Engagement Platform (InCEP)/MyGov 2.0

MyGov is a Government of India's Citizen Engagement Platform which collaborates with multiple Government bodies/ Ministries to engage people in policy formulation and seeks the opinion of people on issues/ topics of public interest and welfare.

#### Achievements:

- Since inception in 2014, MyGov has engaged over 6.06 Crore citizens in participative governance as MyGov Sathis and from July 2021, InCEP came into force and till 31st Dec. 2025 it has achieved over 4.23+ Crore user registration, 823 tasks with over 8.43+ lakhs submissions, 168 discussions hosted with 7.54+ lakh submissions, 1235 quizzes having 2.70 + Crore participations, 131 InnovateIndia Activities has 9.98+ Cr. participations, 64 polls and surveys receiving 30.95+ lakh votes and 165 pledges receiving 2.92+ Crore participations and 2875 Blogs.

### 2.4.4 Digital India Common Services Centre

Setting-up of 4,740 CSCs, with enhanced scope and facilities, at the Gram Panchayat / Village level, has been envisaged under the subject project proposal, to cover 10 districts viz Gandhinagar, Chamba, Puducherry, Chhatrapati Sambhaji Nagar (Aurangabad), Mamit, Jodhpur, Khammam, Pilibhit, Gorakhpur, Leh (Ladakh).

Under the project, these 4,740 CSCs will be upgraded with new common national branding without any other private branding, Promotion and awareness creation of Gol schemes through GPS enabled multi-utility vans is provisioned. New service applications will be developed as and when required by the State Government / Union Government. Further, Information, Education and Communication (IEC) would be provisioned under the project to spread awareness about the Government schemes / services etc

#### Achievements:

- Successfully enhanced 11 CSCs as 11 Model DICSCs
- 4295 number of VLEs selected out of 4740 and enhancement of accessibility in CSC centres including installing ramps, railings, and wheelchair-friendly facilities to help everyone access the services easily.
- Skill development training for VLEs is currently in progress.

### 2.4.5 Digital India BHASHINI

Under the Digital India Programme (DIP), MeitY has undertaken a flagship initiative National Language Translation Mission (NLTM)—popularly known as Mission Digital India BHASHINI, to overcome India’s linguistic diversity and ensure inclusiveness in the digital ecosystem. The Mission was launched by the Hon’ble Prime Minister on 4 July 2022 during Digital India Week at Gandhinagar, Gujarat.

Vision of BHASHINI is to “harness natural language technologies to enable a diverse ecosystem of contributors, partnering entities and citizens for the purpose of transcending language barriers, thereby ensuring digital inclusion and digital empowerment in an AatmaNirbhar Bharat.”

#### Technology

BHASHINI has undertaken several key initiatives to advance the development of indigenous Artificial Intelligence (AI) foundation models. These initiatives include providing state-of-the-art computational resources, scalable infrastructure, and essential linguistic datasets to research & academic institutions including IITs and IIITs in India, startups, and innovators across the country.

BHASHINI platform already hosts 360+ AI based language models in various technologies including:

- Automatic Speech Recognition (ASR): ASR technology processes human speech into readable text.
- Machine Translation (MT): Machine Translation (MT) is an automated translation of text performed by a computer.
- Text to Speech (TTS): TTS converts text into natural-sounding speech.
- Optical Character Recognition (OCR): It is used to turn scanned images and other visuals into text.
- Transliteration: Transliteration is a type of conversion of a text from one script to another.
- Textual & Audio Language Detection models: This model can detect English and Indian languages from the written text.

#### BHASHINI’s Offerings (Products and Applications)

Under the Mission, several user-centric multilingual AI applications have been developed:

- Speech-to-Speech Translation – real-time spoken language conversion
- Anuvaad Web Application – Web Service Text Translation
- Live Transcription & Translation – for events, meetings, and governance
- Video Translation – multilingual subtitling and dubbing
- Document Translation – Document translation and digitization
- Translation Plugins c browser and system-level integration
- BHASHINI Mobile App – Available on Android and iOS, supporting 22 scheduled Indian languages using ASR, TTS and Translation APIs for seamless bilingual conversations. The BHASHINI app has recorded 1.2 million+ downloads.

#### BHASHINI Use cases and Engagement

DIBD has actively engaged a wide network of Central, State, startups, innovators, researchers and experts within the BHASHINI ecosystem, and through innovation challenges, hackathons and field collaborations, this engagement has already delivered numerous impactful use cases and applications.

**Key highlights include:****2.4.5.1 Central Government:**

From the Central Government's perspective, BHASHINI serves as a national multilingual AI infrastructure enabling inclusive access across key services. It powers major governance platforms like e-Gram Swaraj, JanMANREGA, PM-Kisan, Rail Madad, e-Shram, CPGRAMS and Aadhaar, and supports national events such as the Maha Kumbh 2025 with real-time assistance. Government agencies use it for FIR and case-diary translation, while Parliament and legislative bodies rely on it for real-time multilingual content. In sectors like health (e-Sanjeevani), finance (voice UPI, multilingual banking) and skilling (Skill India Digital), BHASHINI strengthens last-mile delivery and citizen accessibility.

**2.4.5.2 State Governments**

BHASHINI has been involved with 25+ for state engagement, collaborating with Assam, Maharashtra, Tripura, Mizoram, Kerala and Gujarat to advance multilingual governance, citizen service delivery, feedback systems, and localized digital initiatives.

**2.4.5.3 Startups/Private Industries**

BHASHINI is driving innovation in India's language-tech ecosystem by providing 200+ startups providing high-performance compute, multilingual datasets, and standardized APIs. This support enables startups to build India-focused ASR, OCR, TTS, conversational AI, and translation solutions, accelerating the growth of domain-specific language technologies. These partnerships strengthen BHASHINI's role in shaping a robust and inclusive multilingual digital ecosystem. Through Grand Innovation Challenges, Hackathons and extensive field collaborations, this ecosystem has already delivered solutions across more than 50 use cases and 25 applications.

**2.4.5.4 Community**

100+ research institutes (including HEIs), 24+ technology partners, and 100+ language experts form a vibrant community of researchers, linguists, technologists, and language practitioners collaborating to strengthen India's multilingual AI ecosystem through shared innovation, co-creation, and capacity building.

**2.4.5.5 GyaanKosh**

BHASHINI's national multilingual AI repository, offering datasets, models, tools, documentation, standardisation resources, and user guides that enable developers, researchers, startups, and government agencies to build India-focused language technologies.

**2.4.5.6 Utsav**

BHASHINI Utsav is a national celebration of innovation and inclusivity, uniting people across states, language days, and cultural moments while showcasing India's diversity through content in 36+ Indian languages.

**2.4.5.7 Pravakta**

BHASHINI's outreach engine focused on Awareness, Adoption and Action, enabling workshops, partnerships and hands-on support to ensure citizens, officials and developers actively use multilingual AI tools. It has been recognised nationally through awards such as the NCeG 2025 Award, Bharat PSU Award and GDHS 2025 Award.

BHASHINI Platform (<https://BHASHINI.gov.in/>) has a repository of models where anyone can submit the model, benchmark the model and can make the model available for wider use. The platform currently supports 36+ languages for text translation, 22+ languages for voice, and hosts a 1.5 million-term multilingual glossary, with its services already

powering 4 billion+ inferences across diverse applications. The total number of datasets recorded is approximately 5000.

#### 2.4.6 Capacity Building Scheme:

The Digital India vision provides intensified impetus to e-governance initiatives to meet the aspirations of its citizens, where the government and its services reach the doorsteps of citizens. Capacity Building scheme under Digital India programme envisions building adequate and relevant capacities at all levels in the Government. The scheme was initially approved in 2008 with training & knowledge sharing initiatives and technical manpower support to bridge the relevant skill-sets and expertise in managing large IT/ e-governance projects and to develop an appropriate institutional framework to handle the capacity building requirements of the States. In 2015, the scheme under Digital India programme was continued under phase-II that included special focus on Central Line Ministries introducing new components for maximum outreach; bringing flexibility, continuity in learning through technology led platforms (LMS); and to handle the capacity building requirements of States/UTs and Central Line Ministries with an appropriate institutional framework. The objective of the project is to provide professional resources to States and provide training to political and policy level decision makers, managers and implementors of all States/UTs and Central Line Ministries to build the in-house capacity for implementation of various e-Governance initiatives. Under CB Phase-II programme, more than 20,000 Government Officials have been trained.

#### Capacity Building Scheme Phase III (CB Phase-III)

The new Capacity Building Project is approved for 3 years to address the augmentation of the competency requirements of the Government officers of Central line Ministries & State/UT, which will help for the speedy implementation of the Digital India transformative initiatives. The project aims to build internal capacities in Government to enable Digital Governance as part of a larger reform of Government service delivery and functioning. Progressive technologies such as AI, Blockchain, Data Analytics, Drones, Cloud etc. have become critical facilitators for Governance. It has a highly profound role in driving optimization and efficiency across all sectors. The capacity building reform components include:

- Training & skilling with specialized training programmes & workshops.
- Deployment of professional resources to State/UT
- Content development & hosting focussing on emerging technologies and needs
- Collaboration and partnerships with national and international institutions
- Continuous engagement and participation of cohort via Centers of Excellence and Communities of Practice.

#### The Capacity Building Scheme Phase III is crucial for several reasons:

- Digital Transformation: It supports the Digital India initiative by building a workforce capable of managing and implementing digital projects.
- Sustainable Development: By enhancing the capacity of government employees, the scheme contributes to achieving Sustainable Development Goals (SDGs) through improved governance and service delivery.
- Innovation and Efficiency: Training in emerging technologies fosters innovation and improves the efficiency of government operations.
- Inclusivity: The scheme promotes inclusivity by ensuring that all levels of government employees, including those in remote and underserved areas, have access to training and development opportunities.

#### Implementation Status (As on December 31, 2025):

- 109 training programmes and webinars are conducted with 8210 participations across all Ministries and Dept. (including international bureaucrats/youth)

- A total of 200+ e-courses on various topics/domains like Digital Transformation, Digital India Projects, emerging technologies, Cyber Security, e-Governance, Procurement and Contract Management have been developed and published on i-Got with 18L+ users enrolled and 13L+ certificates issued till 30<sup>th</sup> Nov'25.
- Development of 18 national case studies is in process. Four case studies on Unified Mobile Application for New-age Governance (UMANG), Direct Benefit Transfer (DBT) in Fertilizers, Andhra Pradesh Online Case Management System (APOLCMS) and DigiLocker have been developed.
- State e-Mission Team (SeMT) is a team of professionals attached to State IT department to provide technical/professional support to the State decision and policy-making bodies (State Apex Committee). 149 professional resources are deployed in CB 3.0 across the country.
- State Capacity Building Workshops were being conducted with a focus on emerging technologies and State Chief Information Security Officer (CISO). Total 13 State CISO and Emerging Technology workshops with 1281 participation were conducted in Madhya Pradesh (MP), Uttar Pradesh (UP), Kerala, Arunachal Pradesh, Tripura, Srinagar, Himachal and Uttarakhand.

#### 2.4.7 E-Greeting Portal and Sampark 2.0:

Enabling Government and citizen engagement in governance leveraging various e-channels (like emails, SMS, Miss-Call, OBD (Out Bound Dialing)) along with enhanced services and offerings of the project.

##### Achievements:

- 289.25 Cr Bulk SMS pushed
- 226.86 Cr second of OBD
- 4559.31 Cr emails
- 28.44 Cr. OTT services
- 7090 Templates designed through crowd sourcing
- 9.33 Lakh e-greeting shared

#### 2.4.8 Awareness and Communication Plan for Digital India:

Awareness and Communication (A&C) is an integral component of the Digital India Programme. Generating and raising the level of awareness about Digital India, its schemes, initiatives and services amongst diverse stakeholders across the country is important.

##### Objectives

##### The main objectives of A&C activities are:

- Expand visibility of Digital India: Expand visibility of Digital India Programme & its projects and services, with emphasis on outreach to Tier 3 & 4 towns and rural pockets of the country for welfare of citizens including their social, economic & education empowerment. The Project aims to inform, educate, and communicate to the citizens about various initiatives under the “Digital India Programme”, thereby empowering them and establishing the brand “Digital India” by way of effective branding exercise across various platforms- Events, Social Media, Mass Media, Rural Outreach etc.
- Help citizens understand the benefits of Digital India.
- Facilitate demand creation for various services leading to more adoption of services
  - ✓ Increase in downloads of app-based services.
  - ✓ Increase in reach on Social Media platforms.

- Create Awareness and wide publicity including event based publicity etc., through various media- social media, radio, TV, print, outdoor media & activities around Government of India Schemes and Digital India services.
- Inform, Educate, Communicate & Sensitize citizens about usage & benefits of services & schemes.
- Expand reach of Digital India programme globally
  - ✓ Leave a footprint in the global sphere
  - ✓ Recognition of India as a hub for Emerging Technologies (RAISE, Global Conference on Emerging Tech etc.)
- Establish the brand “Digital India” by way of effective branding exercise across various platforms- Mass Media, Social Media, Rural Outreach etc.
  - ✓ Facilitate demand creation for various services leading to more adoption of services
  - ✓ Increase in downloads of App based services
  - ✓ Increase in likes on Social Media platforms

### Key Events:

#### National Conference on DigiLocker (November 4, 2025)

The National Conference on “DigiLocker – Enabling Paperless Access for All” was organised at Bharat Mandapam, New Delhi. The Conference brought together senior government officials, leaders from the technology and financial sectors, educationists, and digital governance experts. The discussions highlighted DigiLocker’s evolving role from a secure document storage platform to a cornerstone of trust, convenience, and efficiency across governance, education, and industry, reinforcing India’s Digital Trust Revolution

#### 28th National Conference on e-Governance (September 22–23, 2025)

The 28th National Conference on e-Governance (NCeG) was jointly organised by the Department of Administrative Reforms and Public Grievances (DARPG), MeitY, and the Government of Andhra Pradesh, with Indian Institute of Management (IIM) Visakhapatnam as the Knowledge Partner. The Conference theme, “Viksit Bharat: Civil Service and Digital Transformation,” featured six plenary and six breakout sessions and brought together senior officials, policymakers, academia, industry experts, and awardees to deliberate on innovative practices and emerging trends in e-Governance.

#### IndiaAI Impact Summit 2026 – Pre-Event (September 18, 2025)

A mega pre-summit event at Hotel Ashok, New Delhi was held on September 18, 2025. At the event, Hon’ble HMEIT unveiled the logo and flagship initiatives for the IndiaAI Impact Summit 2026 in the presence of senior MeitY officials, global AI experts, and distinguished dignitaries. Hosted for the first time by a Global South nation, the IndiaAI Impact Summit is guided by the principles of People, Planet, and Progress, and structured around seven thematic pillars: Human Capital; Inclusion for Social Empowerment; Safe and Trusted AI; Science, Resilience, Innovation and Efficiency; Democratizing AI Resources; and AI for Economic Development and Social Good.

#### Semicon India 2025 Conference – September 2-4, 2025)

The ‘SEMICON India 2025’ was organised by India Semiconductor Mission in partnership with SEMI and industry associations under the visionary leadership of Prime Minister Shri Narendra Modi with the aim to position India as a trusted partner in the global Semiconductor Supply Chain and drive forward the vision of the India Semiconductor Mission. As part of its efforts to position India as a global hub for semiconductor innovation and manufacturing, the fourth edition was India’s largest, with over 350 exhibiting companies from 33 countries and regions and a record number of global stakeholders. SEMICON India 2025 was jointly organized by the India Semiconductor Mission (ISM) under the Ministry of Electronics and Information Technology (MeitY) and SEMI, the global semiconductor industry association.

### **IT Secretaries Conclave (July 15,2025)**

To accelerate India's digital transformation IT Secretaries' conclave was organised by MeitY on July 15, 2025 at Bharat Mandapam, New Delhi, which brought together senior officers, policy makers, and domain experts to deliberate on the latest development, to work on strategies, share best practices, and chart the way forward. Impactful sessions on key initiatives such as Aadhaar, India Semiconductor Mission, Cyber Security, indigenous Data Centres as well as some key initiatives from States were presented by senior officers. Government of India has been consistently striving to bolster the vision of Digital India by fostering collaboration among key stakeholders, promoting emerging technologies, and ensuring effective implementation of various digital initiatives across our nation.

### **Electronics Component Manufacturing Scheme, Taj Mansingh (April 26, 2025)**

Hon'ble Union Minister for Electronics and Information Technology, Shri Ashwini Vaishnaw launched the guidelines and portal for the Electronics Component Manufacturing Scheme (ECMS) on April 26, 2025 marking a major step towards strengthening India's electronics manufacturing ecosystem.

### **Launch of Digital Brand Identity Manual (DBIM) & 1st Chief Information Officer (CIO) Conference, Delhi: (Feb 18<sup>th</sup>, 2025)**

MeitY organised the launch of DBIM & the first chief information officer (CIO) conference 2025 aiming to achieve uniform look & feel in government websites, manual defines citizen-friendly user experience by harmonizing visual & voice identities for an enhanced national & global digital footprint of gov.in domain. The event was presided over by Shri Jitin Prasada, Hon'ble Union Minister of State for Electronics and Information Technology and Commerce & Industry and Shri S. Krishnan Secretary for Minister of Electronics and Information Technology, under the Gov.In: Harmonisation of Government of India's Digital Footprint initiative.

Further, events such as Digital India Talk Shows at Universities and Colleges, Consultation Meeting on Application Programming Interface (API) Services onboarding, Bharat Tex 2025, Launch of AI Kosh, Awareness and Sensitization Workshop on User Experience and Design System, 32nd Convergence India 2025 Expo, WAVES Summit, India AI Event, MeitY Pavilion World Expo 2025, Osaka, Kansai, Japan, Global Fintech Fest etc. were also conducted.

### **Social Media Coverage:**

- Digital India Week
- Ask Our Experts
- National Handloom Day
- Har Ghar Tiranga
- Independence Day
- National Space Day
- India's First 2D Material Research Fab
- Digital India Talkshow
- Semicon
- National e-learning day
- CyberJagrit bharat
- National Conference e-Governance

### 2.4.9 Modernization/Digitalisation of Nagaland Fire & Emergency-Management System (NFES-MS):

A pilot project being implemented by Directorate of Fire & Emergency Services, Govt. of Nagaland, with estimated outlay of Rs. 3.88 crore for a period of 30 months, has been sanctioned by MeitY in June, 2023. The objective of the project is to develop a centralized management system for the Nagaland Fire & Emergency Service (NF&ES) for creating a cost effective environment, faster and better service delivery to the department and stake holders, ushering and thus increasing overall efficiency and effectiveness in the Government processes.

**Implementation status:** The project is complete.

- Various software modules of Nagaland Fire and Emergency Services-Management System have been developed such as, Smart Emergency Response System (SERS), File Management System (Digital Office), Citizen Web Portal, Human Resource Management System (HRMS), Global Positioning System (GPS) Monitoring System (using Open-source), Geographic Information System (GIS) Mapping, Mobile App for GPS Monitoring, Asset and Inventory Management, Management Information System (MIS) Reporting, Mobile Application, Users Management, Applications Settings and Configurations.
- Further, setup of networking communication and video surveillance system are completed in all the fire stations (FS) of 3 pilot districts of Nagaland. Setup of Command and Control Centre at NEFS Directorate office is completed and operational.
- Training/Capacity building has been provided to concerned Fire officials and other stakeholders.

### 2.4.10 GOV.IN Appstore:

The Gov.in AppStore, India's indigenous and secure mobile application distribution platform, continues to play a pivotal role in strengthening the nation's digital governance ecosystem. It serves as a one-stop access point for citizens to discover and download verified government and public service applications, ensuring trust, transparency, and accessibility across the country's expanding digital landscape.

#### Achievements:

- The platform now hosts 2450 applications (1,775 Live + 553 Registered + 122 Disabled/ Rejected) and has achieved 8.78 crore downloads, empowering citizens with easy access to government digital services.
- A growing community of 9,970 developers and 2.15 lakh registered users is contributing to the ecosystem.
- Between January 2025 and 20 January 2026, 1,213 new developers registered, and 2.10 lakh new downloads were recorded — reflecting the AppStore's continuous expansion and public adoption.
- Voice search functionality introduced to improve accessibility and ease of navigation. Pagination and responsive design implemented across the web portal for seamless access on all devices.
- Ratings and reviews system implemented with intelligent checks to prevent spam and ensure fair user feedback. Introduced an Impact Assessment banner to collect user insights and monitor service reach.
- Developed a user support system integrating video conferencing and email query support, further enhancing citizen engagement.

### 2.4.11 National Informatics Centre Services Incorporated (NICSI)

National Informatics Centre Services Incorporated (NICSI) is a Government of India enterprise under National Informatics Centre (NIC), Ministry of Electronics & Information Technology (MeitY). It was established in 1995 as section-25 Company (now section 8) with NIC, MeitY as sole promoter. NICSI has expertise in ICT project execution and have executed over 28,000 ICT projects for Ministries /State Governments / PSUs. All key officials in NICSI including Managing Director are

provided by NIC through deputation. NICS I has empanelled organizations based on their expertise in various areas of information technology through an open tender process through which the procurement by the User Department is fast-tracked. NICS I had reached, an impressive 32% jump in its revenues in FY 2024-25 and a turnover of ₹3,110 crores.

This year NICS I celebrated 30 years of its existence and a day long programme was organized. The event was graced by Shri Jitin Prasada, Hon'ble Minister of State for Commerce and Industry; and Electronics and Information Technology.

NICS I has also opened its empanelment for Startups through a RFE wherein Startups with proven IT capabilities are encouraged to apply.

### Awards and Facilitation

- NICS I has been awarded the Technology Sabha Award 2025 by The Indian Express Group under 'Enterprise Applications' category. NICS I was also awarded at the Government Achievement and Scheme Exhibition organized by NNS Media Group. Hon'ble Chief Minister of Puducherry awarded NICS I for the impactful work done through the iRAD and eDAR projects in reducing road accidents.
- The eDAR (Electronic Detailed Accident Report) was awarded by Digitech India award organized by ETGovernment. iRAD Project also won the prestigious, "Gems of Digital India" award. NICS I was awarded with the "Public Sector Excellence Award 2024" under the category of "Telecommunication & Information Technology (Central PSU)" by IRON Mountain.
- MD, NICS I was the "Guest of Honour" for the Annual Regional Conference 2024-2025 organised by the Institute of Company Secretaries of India (ICSI). MD NICS I in order to expand NICS I services met Hon'ble Transport Minister, Government of UP at Lucknow.
- NICS I also participated in live programme, "Ask Our Experts" organized by National e-Governance Division (NeGD). Dr R K Mishra, MD, NICS I and Shri Jitender Kumar, Chief General Manager and Financial Advisor, NICS I gave answers to the questions as posted by the viewers.
- NICS I regularly participates in events of National importance like Hindi Pakhwada, Yoga Day, Holi Milan, Vigilance Awareness Week.

### Key Projects by NICS I

- The Immigration, Visa and Foreigners' Registration & Tracking (IVFRT) project has changed how India manages the flow of travelers and immigrants. By connecting various checkpoints, embassies, and departments, NICS I made the system more secure and much less time-consuming for visitors.
- Through Meghraj project, NICS I offered every branch of government an on-demand, secure digital "backbone," making it easier and cheaper to launch new services. The cloud connects agencies, bridges silos, and helps teams move quickly as new projects emerge.
- NICS I's e-Prisons system takes a complex web of paper records and centralizes them, making prisoner management fairer, safer, and easier to supervise across all of India's states. The iRAD platform harnesses accident data and analytics to build safer roads, letting states and central agencies act quickly to prevent tragedies. Another initiative, Prayas gathers information on the government's major schemes into one place, offering a clean, real-time look at how each is performing.
- NICS I helped in rolling out biometric e-Passports, which brought world-class security and much faster processing to Indian travelers. Immigration queues have shrunk, and document fraud is now much harder, thanks to smart design updates.

- With e-Courts project, NICS I has made it possible for India's judicial and administrative machinery to go digital. That means less paperwork, more open processes, and better service to both citizens and officials who rely on these systems every day.
- The AI-MEDHA (AI Modelling Empowered Digital Hub for Applications) is NICS I's step into real-world artificial intelligence for government departments. It makes analysis quicker, automates routine work, and puts smarter tools in the hands of officials across the country. A MoU was signed between NIC and NICS I to facilitate AI MEDHA as a joint initiative.
- NICS I also offers its cybersecurity platform which offers a strong line of defense for sensitive data. The service keeps digital assets protected and helps government organizations adhere to national security benchmarks.
- Over the years, NICS I has fostered meaningful collaborations through MOUs, joining hands with ministries, states, and technology partners to broaden its reach and enable smoother project rollouts.
- Some of the key clients wherein NICS I is executing projects more than 100 Crores are Ministries of Electronics and Information Technology; Information and Broadcasting; Home Affairs; External Affairs; Road Transport and Highways; Consumer Affairs, Food and Public Distribution; MSME; Social Justice and Empowerment; Finance; Parliamentary Affairs; Administrative Reforms and Public Grievances; Law and Justice.
- NICS I is implementing the National Data Centre for North Eastern Region (NDC- NEC) to be established at Guwahti. The NDC-NER is a state of art data centre to be implemented in North East region.
- NICS I plans to equip itself for future by becoming a Mini Ratna company, expanding its service portfolio, and continuing to put practical, people-first innovation at the core of its mission. It is working on Digital Personal Data Protection Act, 2023 (DPDP) Compliance Service. The DPDP Compliance platform will ensure departments stay aligned with India's newest digital privacy standards, giving citizens peace of mind as government transactions become more technology-driven. Other areas of focus for NICS I are Capacity Building and Cloud Services.

#### 2.4.12 Gov.In: Harmonisation of Government of India's Digital Footprint:

Under the Gov.In: Harmonisation of Government of India's Digital Footprint initiative, the Digital Brand Identity Manual (DBIM) 3.0 was launched on 18th February 2025 with the objective of establishing a uniform, citizen-centric, accessible, and a consistent brand identity across Government of India websites. DBIM 3.0 manual provides a comprehensive framework covering visual identity, information architecture, accessibility, content structuring, and user experience, thereby addressing long-standing fragmentation in government web presence and ensuring consistency.

To support systematic adoption of the DBIM, the DBIM Toolkit was subsequently launched which serves as the single source of reference for DBIM-aligned website development. The toolkit provides Ministries and Departments with detailed implementation guidelines, standard templates, reusable design components, content patterns, and compliance standards, enabling uniform interpretation and execution of DBIM 3.0. The toolkit is accessible at <https://dbimtoolkit.digifootprint.gov.in/>.

Building on this foundation, the Gov.In CMS Platform was conceptualised and developed to operationalise DBIM 3.0 at scale. The platform enables Ministries and Departments to implement DBIM-compliant websites in a structured, standardised, and auditable manner, covering defined workflows, maker-checker-approver roles, content management processes, and compliance controls. To enhance inclusivity and multilingual reach, the platform leverages Bhashini to provide on-the-fly translation of website content into 22 Indian languages, significantly improving accessibility for non-English users. In parallel, the Central Content Publishing System (CCPS) was integrated to harmonise the dissemination of time-sensitive, citizen-centric content across Government websites, ensuring consistency in messaging and faster outreach.

As part of the initial rollout, five exemplar Government of India websites were made live at the time of the DBIM launch to demonstrate practical implementation of the framework and serve as reference models for Ministries and Departments. Subsequently, as of date, six Ministry/Department websites have been successfully migrated and are live.

The harmonisation initiative is presently being accelerated with emphasis on DBIM 3.0 compliance, thereby progressively realising the vision of a unified, accessible, citizen-first, and globally recognisable digital footprint for the Government of India.

## 2.4.13 Digital Economy

### 2.4.13.1 Background: India's Digital Economy

India's digital economy has been expanding at an exceptional pace over the past decade, driven by rapid technological adoption, progressive public digital infrastructure, the evolving dynamic innovation ecosystem etc. This transformation has positioned India among one of the world's leading digitalizing economies.

According to the latest estimates, the digital economy contributed 11.74% of national income in 2022–23, valued at INR 31.64 lakh crore (~USD 402 billion). Digital-enabling industries—ICT services, telecommunications, and electronics manufacturing—form the largest component with 7.83% of GVA, while new digital industries such as platforms and digital intermediaries contribute nearly 2%. Traditional sectors including BFSI, trade, and education add an additional 2% through their growing digital components, underscoring the deepening digitalisation of India's economic landscape.

Employment in the digital economy stood at 14.67 million workers (2.55% of the workforce) in 2022–23, with productivity nearly five times higher than the rest of the economy. Projections indicate that the digital economy will grow almost twice as fast as overall GDP and is expected to reach around 20% of national income by 2030.

India's digital transformation is accelerated by strong progress in Artificial Intelligence (AI) ecosystem, with vast applications across governance, agriculture, healthcare, mobility, and finance. The semiconductor and electronics ecosystem continue to strengthen through new investments in fabrication, assembly and testing, semiconductor design, and production-linked incentive schemes. These developments support domestic manufacturing and meet growing demand from strategic sectors such as telecom, EVs, cloud, and IoT systems. Global Capability Centres (GCCs) have also emerged as a key pillar of India's digital and innovation landscape, with global enterprises increasingly relying on India for high-end engineering, product development, AI/ML research, cybersecurity, semiconductor design, and digital operations.

Further, India's globally recognised Digital Public Infrastructure (DPI)—including Aadhaar, UPI, DigiLocker, FASTag, Account Aggregator, DIKSHA, and ABDM—remains central to inclusive growth. DPI enables secure identity, seamless digital payments, paperless service delivery, and interoperable data exchange, while fostering a strong foundation for private-sector innovation, GCC expansion, and digital entrepreneurship. Together, these developments highlight India's evolution into a digitally integrated and innovation-driven economy, where technologies such as AI, semiconductors, and DPI—supported by a strong GCC ecosystem—drive productivity, competitiveness, and inclusive growth.

### 2.4.13.2 Banking and Fintech Ecosystem: An Overview

India's banking sector stands as a pillar of the nation's economic progress, playing a vital role in mobilising capital, expanding credit access, and driving financial inclusion. While it continues to navigate challenges such as regulatory shifts, rising operational costs, and growing competition from fintech players, the sector is simultaneously embracing opportunities brought by digital innovation, structural reforms, and evolving customer needs.

India's fintech sector is rapidly evolving, driven by technological advancements, regulatory support, and a robust digital ecosystem. India's fintech ecosystem encompasses a diverse range of segments that collectively transform the financial

landscape. The payments sector, driven by digital wallets, UPI, and contactless technologies, enables seamless and secure transactions. Regtech supports regulatory compliance with cost-effective solutions, and fintech enablers offer the technological backbone that fuels innovation and scalability across the sector.

Digital transformation in India's financial ecosystem has been significantly driven by Digital Public Infrastructure (DPI), with platforms like Aadhaar, UPI, and DigiLocker playing a pivotal role in enhancing financial inclusion and accessibility; UMANG is providing various Bharat Bill Payment Services. Further, with the development of Open Credit Enablement Network (OCEN) & Account Aggregator (AA) framework, number of Fintechs are going to be increase further to develop the citizen centric services in BFSI sector. Complementing this shift, the rise of Banking-as-a-Service (BaaS) has enabled banks to offer APIs backed by API Setu, allowing and encouraging fintech companies to innovate and build upon existing banking infrastructure, thereby fostering a more collaborative and agile financial landscape.

In order to strengthen and institutionalize mechanisms for ensuring financial stability, driving financial sector development, enhancing inter-regulatory coordination, shaping policy, and advancing technology-led innovations, particularly in areas such as fintech ecosystem development and payment fraud mitigation, etc, MeitY is actively participating in and supporting a wide range of national Banking and Fintech Committees.

These committees engage in critical activities including, Finalization of the Fintech Vision and Strategy report to guide India's fintech roadmap, Establishing the Digital Payments Intelligence Platform as a Section 8 company to leverage advanced technologies such as AI/ML, network analytics, and real-time monitoring for preventing and mitigating payment fraud, Integrating DigiLocker and Aadhaar more deeply into banking and fintech operations, including strengthening frameworks for e-KYC, ULI, and consent-based data sharing, Expanding and enhancing the Aadhaar Bridge Payment System, and improving authentication mechanisms for secure, inclusive financial transactions, etc.

Through these engagements, MeitY plays a pivotal role in enhancing the trust, security, innovation, and resilience of India's digital financial ecosystem, while ensuring that technological advancements align with national priorities for financial inclusion, consumer protection, and economic growth.

### 2.4.13.3 Building an Inclusive Digital Economy

An inclusive digital economy ensures that every individual—regardless of geography, gender, income, or ability—can participate meaningfully in the digital age. It leverages technology to reduce inequality, empower communities, and drive sustainable economic growth.

- **Digital Access and Infrastructure:** In order to bridge the digital divide and foster inclusive growth, it is essential to expand universal connectivity by enhancing broadband and mobile networks in underserved rural and urban regions. Promoting affordable devices such as low-cost smartphones, tablets, and computers through subsidies or public-private partnerships can further empower individuals with access to digital tools. Additionally, ensuring that digital platforms are accessible to people with disabilities and available in local languages is crucial for creating an inclusive digital ecosystem that serves all segments of society.
- **Inclusive Financial Services:** Advancing financial inclusion in the digital age involves promoting mobile wallets and UPI-like systems to facilitate cashless transactions, thereby enhancing convenience and security. Digital platforms play a crucial role in expanding microfinance access by delivering microloans and insurance products to low-income populations. Additionally, leveraging digital IDs enables the onboarding of unbanked individuals into formal financial systems, fostering broader participation in the economy.
- **Policy and Governance:** Building a robust digital economy requires a strong regulatory foundation that prioritizes user rights, improving security, securing privacy promoting innovation etc. Promoting open data through accessible government datasets can foster transparency and drive technological advancement. Inclusive regulation should also be a key focus, with policies designed to support startups, gig workers, and digital cooperatives, ensuring that the benefits of digital growth are equitably distributed across all segments of society.

- Bridging the Digital Divide: Fostering inclusive digital development requires targeted efforts across diverse communities. Promoting gender equity involves addressing the barriers that hinder women from accessing and benefiting from digital tools. Rural empowerment can be achieved by leveraging digital platforms to connect farmers, artisans, and remote workers to broader markets, enhancing their economic opportunities. At the same time, engaging youth through innovation hubs and digital internships helps cultivate talent and drive future growth in the digital economy.

An inclusive digital economy is not just a technological aspiration—it's a moral imperative. By investing in infrastructure, education, and equitable policies, nations can unlock the full potential of their people and build resilient, future-ready societies.

#### 2.4.13.4 Economic Planning

Economic Planning plays a pivotal role in the formulation, coordination, monitoring, and analysis of economic and statistical aspects related to the programmes, schemes, and initiatives of MeitY. It acts as a crucial interface between MeitY and various central ministries such as the Ministry of Finance (MoF), Ministry of Statistics & Programme Implementation (MoSPI), Ministry of Tribal Affairs (MoTA), Ministry of Social Justice & Empowerment (MoSJE), NITI Aayog, etc.

It involves a range of planning and policy responsibilities that facilitate evidence-based decision-making, programme evaluation, and effective outcome monitoring across the Electronics and Information Technology sectors. Its work directly contributes to enhancing transparency, accountability, and performance measurement within MeitY's schemes and projects.

- The Output–Outcome Monitoring Framework (OOMF) involves matters related to the Central Sector Schemes of MeitY including the quarterly updating of progress status on the OOMF Dashboard maintained by NITI Aayog. Accordingly, it is ensured that measurable indicators and outcome parameters are regularly captured, monitored, and reported in line with NITI Aayog's guidelines, thereby strengthening the result-oriented management of MeitY's programmes.
- All matters concerning the Development Action Plan for Scheduled Castes (DAPSC) and Development Action Plan for Scheduled Tribes (DAPST) are also looked after including initiatives related to Gender Budgeting to ensure that MeitY's programmes are inclusive and aligned with national social equity goals. These responsibilities involve regular coordination with the Ministry of Tribal Affairs, Ministry of Social Justice & Empowerment, and other relevant departments for compliance, reporting, and monitoring of progress on inclusion targets. Timely submission of required data, inputs, reports and maintaining close liaison with these ministries for cross-sectoral planning and review purposes is also ensured.
- The information pertaining to MeitY's programmes, achievements, and policy outcomes for inclusion in the Economic Survey of India is provided. This involves preparation and submission of analytical inputs, sectoral highlights, and key statistical indicators that reflect MeitY's contribution to the digital economy and national development. Also, miscellaneous economic and statistical analysis concerning the Electronics and IT sectors are undertaken. These analysis support policy formulation, sectoral studies, and impact assessments, and also provides evidence-based insights to inform decision-making, programme design, and evaluation of policy outcomes.
- Any economic policy matter referred to MeitY for examination is processed and policy implications is evaluated, recommendations provided, and contributed to inter-ministerial consultations or committees as required. This includes special studies, preparation of statistical compendiums, and supporting digital economy research and monitoring activities initiated by MeitY or NITI Aayog.

In essence, these activities serve as the analytical and policy-support backbone of MeitY. Through its work on OOMF, inclusive budgeting (DAPSC/DAPST/Gender), Economic reporting, Statistical analysis etc., it ensures that policy implementation remains transparent, accountable, and outcome-driven. These contributions are vital in aligning MeitY's programmes with the national objectives of inclusive growth, digital transformation, and evidence-based governance.

## 2.5 Digital India Initiatives by NIC

National Informatics Centre (NIC) offers an extensive range of digital platforms and services for eGovernance. These citizen-centric solutions cater to sectors such as Agriculture, Education, Health & Family Welfare, Transport, Finance, Law and Justice, Social Welfare & Skill Development, Consumer Affairs, Food & Public Distribution, and many more.

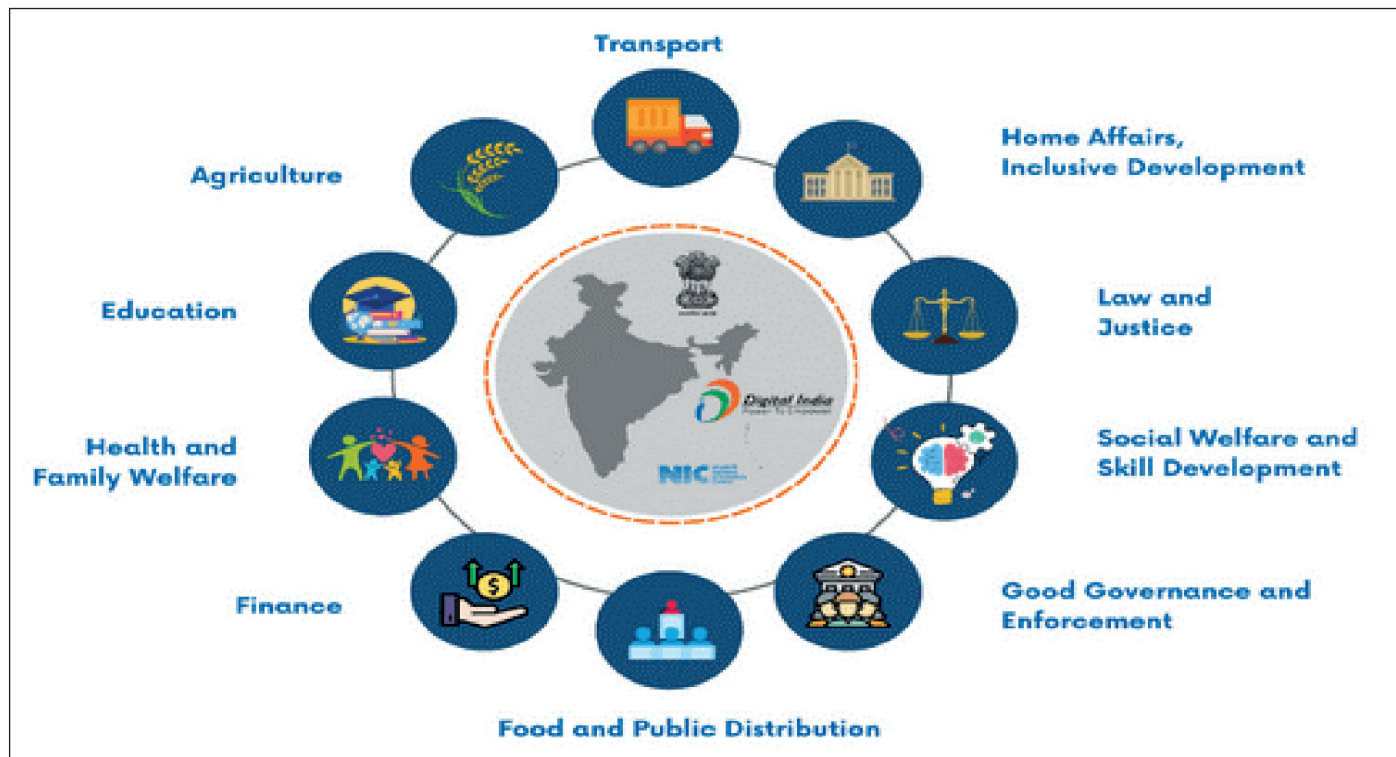

**Digitizing Core Sectors for Sustainable National Development**

### 2.5.1 Agriculture & Food Processing

#### 2.5.1.1 PM KISAN- Pradhan Mantri Kisan SAMman Nidhi (<https://pmkisan.gov.in/>)

Pradhan Mantri Kisan Samman Nidhi (PM-KISAN) portal developed and managed by NIC provides an end-to-end technology solution for transferring the funds directly into the accounts of the farmers identified by States/UTs. Under the PM-KISAN Scheme, eligible landholding farmer families receive ₹6,000 annually through three installments of ₹2,000 each, disbursed every four months directly into their bank accounts via the PM-KISAN portal. With the 20th installment release, the total disbursement under the scheme exceeded ₹ 3.90 lakh crore, supporting more than 11 crore farmers nationwide.

#### PM KISAN Mobile App (<https://play.google.com/store/apps/details?id=com.nic.project.pmkisan>)

The PM-KISAN mobile app enhances transparency and expands farmer outreach, serving as a simple and efficient extension of the PM-KISAN web portal.

### 2.5.1.2 Seed Authentication, Traceability and Holistic Inventory (SATHI) (<https://seedtrace.gov.in>)

Seed Authenticity Traceability & Holistic Inventory (SATHI) is a national platform implemented by the collaborative efforts of the Ministry of Agriculture and Farmers' Welfare, Government of India, and the National Informatics Centre (NIC). It provides a digital platform that streamlines the holistic management of seed production, quality certification, distribution, and traceability pan-India. This endeavour establishes a National Seed Grid (NSG), integrating all seed stakeholders within a unified national digital platform.

### 2.5.1.3 FARMAP 2.0 (Farm Analysis Package) (<https://farmap.dac.gov.in>)

FARMAP is a web-based system developed by NIC to facilitate capturing of data from 19 states, 810 sample Tehsils, 1620 sample Villages and 9720 sample farmers in 22 Record Types. The data is processed to generate Crop wise state level cost estimates.

### 2.5.1.4 e-Urvarak – Integrated Fertilizer Management System (IFMS)

<https://dbtfert.nic.in/> - IFMS,

<https://urvarak.nic.in/> - IFMS Dashboard,

#### **Mobile Applications: e-Urvarak PoS App (Android) for Aadhaar-authenticated fertilizer sales**

The e-Urvarak platform plays a pivotal role in ensuring that fertilizers — the lifeline of Indian agriculture — reach the right farmer at the right place and time. Covering the entire value chain from plant/port to retail counter and sale to fertilizer buyers using biometric authentication on POS devices, the system captures every transaction digitally and links it directly to subsidy payments. The platform provides live visibility of production, stock, logistics, and sales, enabling the Government to swiftly respond to regional shortages or disruptions.

### 2.5.1.5 SAMPADA Suite (<https://sampada-mofpi.gov.in>)

NIC has developed a web-based application suite named “Sampada Portal” for various schemes under which the Ministry of Food Processing Industries (MoFPI) which provides grants to various promoters desirous of setting up different types of Food Processing Facilities. The different modules of the suite, based on different schemes of the Ministry provide an online system for submitting application for setting up food processing facilities, evaluation of the same by the different divisions of the Ministry and Project Management Agencies engaged by the ministry, approval/rejection of applications, monitoring of grant release instalments and final closure of a project.

The Operation Greens module and its Atmanirbhar Bharat functionality help farmers/cooperatives etc. to transport their produce from farm gate and sell it to any market or store it to any cold storage/warehouse of their choice in India. This facility has enabled the farmers to get the best price for their produce.

### 2.5.1.6 PMFME Portal (<https://pmfme.mofpi.gov.in>)

A national level portal ([pmfme.mofpi.gov.in](https://pmfme.mofpi.gov.in)) has been developed for the Ministry of Food Processing Industries (MoFPI) under NIC's supervision which has automated the complete workflow starting from registration, generating a DPR and submission of application for grant by various micro food processing enterprises, evaluation of the applications by the District Level Committee/Ministry, forwarding application to bank for sanction of loan, sanction of loan by bank, sanction of grant by the Ministry, providing training and handholding support for upgradation of skills and technical knowhow, providing branding and marketing support, getting financial support from other such schemes of the Central/State Government etc. In addition, the portal also generates MIS reports of various kinds for all these activities, maintains accounting and budget information, integrates with a Learning Management System and a GIS based system showing One District One Product data on the geographical map of India and also individual districts.

### 2.5.1.7 Farmer Registration and Unified Beneficiary Information System (FRUITS)

(<http://fruits.karnataka.gov.in>)

FRUITS is an e-Governance project for managing and maintaining farmer registry which can be used by all agriculture and allied departments for providing benefits under various government schemes to eligible farmers. FRUITS is evolving as a soft infrastructure project in the agriculture sector acting as an inventory of farmers, land owned by them, and benefits extended.

## 2.5.2 Health & Family Welfare

### 2.5.2.1 ORS, e-Hospital and NextGen e-Hospital

#### Online Registration System (<https://ors.gov.in>)

ORS is an online patient portal for citizens to book online appointments for the hospitals and for providing patient centric services like viewing lab reports, checking blood availability status, and making online payment and getting the eOPD card on the day of appointment. Citizens can now use the ORS portal in English, Hindi, and 14 other languages. These include Assamese, Bengali, Gujarati, Kannada, Kashmiri, Malayalam, Nepali, Odia, Punjabi, Sanskrit, Sindhi, Tamil, Telugu, and Urdu.

#### e-Hospital application (<https://ehospital.gov.in>)

The **e-Hospital application** is being offered as an as-is product to the government hospitals across the country through SaaS (Software as a service) model. The modules of e-Hospital application which are currently available on cloud are Patient Registration (OPD & Casualty), IPD (Admission, Discharge & Transfer), Billing, Lab Information System, Radiology Information System, Clinic, Dietary, Laundry, Store & Pharmacy and OT Management. Now hospitals using eHospital platform are being migrated to NextGen eHospital platform, around 800 hospitals out of 1000+ hospitals have been migrated till now.

#### NextGen eHospital Platform (<https://nextgen.ehospital.gov.in>)

The NIC-developed NextGen eHospital system is a cloud-based, microservices-driven Hospital Management Information System (HMIS) designed to modernize hospital operations and provide patient-centric digital healthcare. It has been designed in alignment with nationally/internationally recognized healthcare data and process standards to ensure seamless interoperability across healthcare providers. It adheres to ABDM standards, including HL7, SNOMED-CT, and FHIR, enabling standardized data exchange between hospitals, labs, and government health registries.

With seventeen fully developed modules including OPD/IPD management, patient registration, billing, pharmacy, laboratory information system, radiology, OT, dietary, laundry, emergency, ambulance, discharge and follow-up, queue management, and ePrescription, the platform captures the entire spectrum of hospital workflows on a single digital backbone, ensuring seamless digital health services and interoperability with national platforms such as ABDM, eCollabDDS and eSanjeevani.

During the year 2025–26, major progress was achieved through the migration of all core components to NGC 2.0 cloud infrastructure, enhancing scalability, security, and performance. Over 3,000 health facilities across Central and State Government hospitals have been onboarded, including medical colleges, district hospitals, Community Health Centres and Primary Health Centres. Usage has reached significant scale with 5 lakh OPD registrations in a single day, over 1 Crore IPD registration and over 1.6 Crore ePrescriptions generated to date. The platform now features centralized analytics, role-based dashboards, and data-driven insights to support informed decision-making and improve service delivery.

The NextGen eHospital platform has played a crucial role in delivering seamless digital health services to Indian Haj Pilgrims in the Kingdom of Saudi Arabia during the Haj seasons from 2023 to 2025. The system was deployed across 24 health facilities, 20 in Makkah and 4 in Madinah. During these three years, the platform enabled the generation of more than 8,00,000 digital prescriptions, significantly improving clinical efficiency, reducing manual errors, and ensuring complete traceability of patient care records. All core and advanced modules of the NextGen eHospital were fully operational across the deployed sites, supporting end-to-end healthcare workflows including OPD registration, clinical services, IPD, pharmacy, LIS, RIS etc.

NextGen eHospital has also been implemented in 42 Central Armed Police Forces hospitals of the Ministry of Home Affairs across the country.

### 2.5.2.2 Central Government Health Scheme (<https://cghs.nic.in>)

Central Government Health Scheme caters to the healthcare needs of eligible beneficiaries enrolled under the scheme). Above 47 lakh beneficiaries are enrolled for CGHS health services. 470 Wellness Centers (Dispensaries) across 74 cities cater health and wellness services under supervision of 24 Additional Director Offices in Allopathic and AYUSH (Ayurvedik, Yoga, Unani, Siddha, Homeopathic) systems. The beneficiaries can book appointments, download CGHS Cards, search Dispensaries, empanelled Hospital/ Labs through Mobile App. DigiLocker may also be used to download CGHS plastic cards.

### 2.5.2.3 Reproductive & Child Health (RCH)

Reproductive and Child Health (RCH) is an innovative name-based system to capture information on all RCH related services including family planning, maternal health, Child health, and immunization and to monitor performance at all levels (National, State, District, Block, PHC and Sub Centre level). ANMOL (ANM online) is a tablet based android application for RCH, which allows ANMs to enter and update service records of beneficiaries (Eligible Couple, Pregnant Women and Children). RCH/ANMOL have been integrated with Ayushman Bharat Digital Health Mission (ABDM).

### 2.5.2.4 NHM-PMS (National Health Mission - Progress Monitoring System) (<https://nhmpms.gov.in>)

National Health Mission Progress Monitoring System (NHM PMS) is an application developed for allocating, managing, monitoring, and updating the physical and financial progress for various health schemes from top to grassroot level. It is a Single Sign On (SSO), two factor Authentication, user friendly and 24\*7 available portal with inbuilt informative dashboard, various reporting format, and user-based query reporting tool.

### 2.5.2.5 Sickle Cell Anaemia Elimination Mission

The National Sickle Cell Anaemia Elimination Mission program is currently being implemented in 17 identified states, including Gujarat, Maharashtra, Rajasthan, Madhya Pradesh, Jharkhand, Chhattisgarh, West Bengal, Odisha, Tamil Nadu, Telangana, Andhra Pradesh, Karnataka, Assam, Uttar Pradesh, Kerala, Bihar, and Uttarakhand. Sickle Cell Disease is a group of blood disorders genetically inherited and specially found in the tribal population of India. This mission mode project supports enrolment, testing, identification, and maintenance of electronic health records of citizens screened for Sickle cell disease, Thalassemia disease & other blood disorders.

### 2.5.2.6 Indian Public Health Standards (IPHS) Dashboard

IPHS (Indian Public Health Standards) are a set of uniform standards envisaged to improve the quality of health care delivery in the country. Standards have been revised as IPHS 2022. The IPHS Dashboard is a digital platform for monitoring IPHS compliance status of public health facilities. Dashboard Provides a comprehensive overview of the assessment status and compliance status.

### 2.5.2.7 Haj Health Professionals Deputation System (<https://hajdeputation.mohfw.gov.in>)

A web-based system has been developed for (i) online application submission by Health professionals. (ii) eSign on application by applicant. (iii) Approval of application by respective State Nodal Officer & eSign. (iv) Online scrutiny and selection of applicants at central level. (v) Deployment of applicants as per the posts sanctioned by the Ministry of Minority Affairs.

### 2.5.2.8 Haj Pilgrims Health Information System (<https://hphis.eHospital.nic.in>)

An IT system has been developed and implemented to capture and maintain records of each Haj Pilgrim (Haji). Demographic details and health profile (screening data) is entered in the system. The system also facilitates monitoring of the status of screening of Haj Pilgrims.

## 2.5.3 Finance

### 2.5.3.1 Public Financial Management System (PFMS) (<https://pfms.nic.in>)

The Public Financial Management System (PFMS) is a Project of the Government of India and is being implemented by the Office of Controller General of Accounts, Ministry of Finance with the National Informatics Centre (NIC) as its Technology Partner. Key features include:

- Financial Network for payments, receipts, and accounting.
- Complete tracking of funds disbursement under all Central Sector (CS) & Central Sponsored Scheme (CSS) Schemes from the concerned ministry to end-beneficiary.
- Just in time Transfer of Funds
- Direct Benefit Transfer.
- Successful delivery of payment services from Government Treasuries and Program Implementing Agencies (PIA) into payees' accounts, including DBT.
- Management Information System for the Government of India, Ministries Departments, and the sub-National Governments.
- Integrated with 684 Banks, 250+ External systems, 31 State Treasury/Dept, 30 lacs+ Implementing Agency, NPCI & eKUBER of RBI.

### 2.5.3.2 e-Way Bill (<https://ewaybillgst.gov.in>; <https://ewaybill2.gst.gov.in>)

The GST e-Way Bill mechanism is put in place to ensure that goods are transported in accordance with GST laws and tax is paid for the supply of goods. e-Way Bill is an electronic document which gives details regarding the movement of goods and needs to be carried by transporters for any consignment exceeding Rs.50,000. e-Way bill has been interfaced with Fastag-RFID and Vahan system to verify/monitor the movement of vehicles updated in e-Way Bill. RFID based EWB reports have helped the department officers in conducting effective vigilance on the roads. The Comprehensive Analytics on e-Way Bill system for officers has helped in identifying fraudulent transactions by taxpayers. The application is a time critical application that caters to the stakeholders round the clock with DR and parallel setup for business continuity. The taxpayers and logistics operators can use multiple modes of operations. Around 50 lakhs E Way Bills are generated per day on an average.

### 2.5.3.3 GST Prime

GST Prime is an Analytical tool, developed by NIC for the GST officers. This has played an important role in improving the indirect tax collection of the State as well as of the Central GST. The GST officers have been dependent on the

application for their day-to-day activities in terms of monitoring the tax compliance, to identify and initiate appropriate actions against the non-filers of returns, identifying and highlighting the possible fraudulent activities carried out by taxpayers in order to evade taxes, establishing relations / possible links with other stakeholders in case of frauds, identifying and reversal of ineligible Input Tax Credit claims and having complete information on the taxpayers through the taxpayer profile etc.

GST Prime is now rolled out for all the States and Central GST formations across the country from a common infrastructure. GST Prime 4 with new features has been rolled out.

#### 2.5.3.4 e-Invoicing System (<https://einvoice1.gst.gov.in> , <https://einvoice2.gst.gov.in>)

GST e-invoicing system is a system of reporting the invoices being issued by the taxpayers to their customers, on the Government portal on a near real time basis and obtaining a unique Invoice Reference Number (IRN). E-invoice system was launched on 1st October 2020 for the taxpayers in a phased manner based on the Annual Aggregate Turn Over (AATO) and is now mandatory for all the taxpayers above Rs 5 Crore.

It has many advantages for businesses such as standardized & digitally verifiable e-Invoices, enhanced interoperability between various stakeholders- suppliers, recipients, transporters, Government and financial institutions, auto-population of invoice details in GST returns and e-way bill. It has also controlled the issuance of fake invoices or claiming excess input tax credit and at the same time facilitating quick ITC credit to the genuine recipients. In the last 5 years, over 1000 Crore of e-invoices have been generated.

#### 2.5.3.5 Indian Customs Electronic Data Interchange System (ICES)

ICES Application covers around 99 percent of India's International Trade taking in its ambit 560 locations (including SEZ sites) spread across the country.

Major benefits of ICES include - data consolidation for National Level Management Information Systems (MIS) to support future trade policy, standardization of customs clearance methodologies, and the implementation of contactless, paperless, and faceless procedures. It provides real-time duty rate updates and expedites customs clearances, reducing processing times and enhancing overall efficiency. ICES transforms customs operations into a more streamlined and user-friendly experience.

#### 2.5.3.6 e-Auction India (<https://coaleauction.co.in>)

eAuction India is an online auction platform that enables government departments and organisations to conduct transparent auctions for the sale, purchase, and lease of various commodities. It supports forward and reverse auctions, as well as multi and single lot formats. The platform has been adopted by 23 States and Union Territories along with 37 Central Government organisations. The platform has been used to facilitate the 2nd round of Presidential Gift Auction (eUpahaar) and 7<sup>th</sup> Round of eAuction of PM Mementos.

### 2.5.4 Education

#### 2.5.4.1 School Learning and Management Platforms

NIC's School Education Solutions have a broad-reaching impact, ensuring that basic education is accessible to students from diverse backgrounds and all corners of society, thus benefiting a wide range of individuals.

#### Integrated ShalaDarpan Portal (<https://rajshaladarpan.nic.in/>)

The Integrated ShalaDarpan Portal, developed by NIC Rajasthan, is a comprehensive tool supporting over 66,000 government schools, tracking the academic progress of 95+ lakh students and 4.3+ lakh staff members. It streamlines

daily operations like admissions, attendance, and exams, while efficiently managing staff recruitment, posting, and beneficiary schemes. The portal disburses Rs. `1,500 crore in Direct Benefit Transfer (DBT) scholarships, ensuring financial aid for 50+ lakh students.

### **RAJPSP Portal (<https://rajpsp.nic.in>)**

The RAJPSP Portal, developed by NIC Rajasthan, efficiently manages 42,000 private schools and over 90 lakh student admissions. This bilingual portal streamlines processes like RTE admissions, reimbursements, and school recognition (Manyta), ensuring transparency and accountability. With `3000 crore processed for 12 lakh RTE students, it supports online applications, fee determinations, and school verifications.

### **SSPortal (<https://ssportal.kerala.gov.in>)**

The SSPortal by NIC Kerala grades 304 special schools in Kerala, serving 15,000 students, and allocates packages based on grades. The (<https://dhsetransfer.kerala.gov.in>) manages transfers for 13,000 higher secondary teachers in 847 government schools. The vhsTransfer (<https://vhseportal.kerala.gov.in>) handles 2,500 vocational teachers across 262 schools.

### **School Education Portal Uttarakhand**

NIC Uttarakhand's School Education Portal provides a comprehensive eGovernance platform for the state's educational sector. It digitally houses profiles for approximately 61,000 teachers, 20,000 schools, and over 800,000 students, streamlining processes like teacher transfers, document verification, and guest teacher recruitment. With features like the DAKSH dashboard for performance monitoring and e-Service books, it enhances transparency and efficiency in managing educational resources.

### **Chandigarh Online Admission Portal**

The Chandigarh Online Admission Portal revolutionizes the admission process for 112 government and 57 recognized private schools for the 2024-25 academic session. With 2,820 total applicants, 2,721 were eligible, resulting in 836 successful placements via a transparent online lottery system. This centralized platform ensures fair access and simplifies applications for parents.

The SARAL Education Project by NIC Maharashtra integrates platforms like the RET Portal for RTE admissions, SanchManyta Portal for staff approvals, School Portal for school data, and the Sanstha Portal for institutional mapping. SARAL supports over 117,000 schools, 2.14 crore students, and 5.70 lakh teachers. The Mid-Day Meal (MDM) Portal benefits 86,000+ schools, while the eMarksheet Portal offers online verification of 6.1 crore 10th and 4.23 crore 12th records.

## **2.5.4.2 Examination, Admission and Result Service**

### **Examination Services - <https://examinationservices.nic.in/index.html>**

The Examination Service Platform is a unified digital solution that delivers comprehensive examination-related services to Public Examination Authorities across India. It ensures full compliance with the provisions of the Public Examination Act, 2024, as well as the Standards and Guidelines notified by the Government of India for Public Examinations.

The platform provides a single, web-based, configurable solution that enables various examining bodies to conduct academic, recruitment, and entrance examinations at both Central and State levels. It aims to address and eliminate the challenges faced by candidates throughout their examination journey from registration to result display by enabling timely, seamless, and transparent dissemination of information related to all examination activities.

It supports both pre-examination and post-examination processes for Public Examination Authorities such as the National Testing Agency (NTA), CBSE, and other bodies. Key functionalities include Candidate Registration and

Application Form Services, including Registration, Form Submission, Aadhaar Verification, AI-based Image Verification, Document Upload, and Examination Fee Payment, hosting and Display of Advance Exam City Intimation, Admit Card, and Score Card. OMR and Question Paper Display, along with Answer Key Challenge facility. Interactive Dashboards for monitoring, analytics, and candidate grievance redressal throughout the examination lifecycle.

The services offered under the platform are utilized for major National and State Level Examinations such as JEE (Main), NEET (UG), CUET (UG & PG), UGC NET, CSIR NET, CTET, and others.

#### **e-Counselling Service - <https://ecounselling.nic.in/services>**

The e-Counselling of the National Informatics Centre (NIC) was established with a transformative vision to digitize and streamline India's complex examination and admission processes under e-Counselling ecosystem across India. The system pioneered a nationwide, end-to-end digital counselling platform that provides examinations, admissions, seat allocation and document verification into a unified, transparent ecosystem.

Since inception, the e-Counselling system has successfully delivered counselling for prestigious national-level examinations such as JEE Advance, MCC, NIFT, JoSAA, CCMT, CCMN, CSAB, NIMCET, and numerous state-level admissions such as JEECUP, WBJEE, OJEE, etc., covering millions of aspirants annually. The platform ensures merit-based seat allocation, equitable opportunity, and seamless access to institutions of national importance across engineering, medical, management, allied sciences etc.

The platform provides end-to-end digital support for counselling and admissions including, Reporting, E-Admission Letter, Admin Panel with Multiple Provision, Online Seat matrix Uploading, Candidate Registration, Choice Filling and Choice Locking.

This year, the e-Counselling system redefined admission processes through the DASA and CSAB-Special Rounds counselling platforms. The system offers a centralized, digital, and transparent process for registration, document verification, choice filling, real-time fee payment, and seat allocation across all participating NITs, IITs, IEST, and GFTIs.

The e-Counselling system further enhanced its digital counselling platforms by integrating multiple digital public infrastructure services and communication tools to improve efficiency and user experience-WhatsApp, DigiLocker, and Unique Disability ID (UDID). Multi-part payment services were introduced, enabling users to make payments in multiple installments through various modes such as debit/credit cards, net banking, and UPI, integrated via secure payment gateways, while notification services via SMS, email, and Sandes.

#### **Result Services - <https://www.results.nic.in>**

The Result Services platform, developed by the Public Examination Projects Division of NIC, serves as a centralized digital gateway for accessing examination results across India. It provides a unified interface for publishing academic, entrance, and recruitment examination results from various Central and State Boards, Universities, and Councils. Designed to ensure transparency and efficiency, the platform supports a wide range of examination authorities and simplifies result dissemination for millions of candidates nationwide.

It currently hosts results from 19 Examination Bodies, covering 118 different types of examinations conducted at both national and state levels. The platform includes results from 16 states, ensuring broad accessibility and transparency for millions of candidates.

#### **2.5.4.3 National Scholarship Portal (<https://scholarships.gov.in/home>)**

The National Scholarship Portal (NSP) serves as a comprehensive, end-to-end solution for streamlining scholarship disbursement. The key features like the OneTime Registration (OTR) process, which allows students to register once

and use the credentials throughout their academic career. Aadhaar-based Face Authentication (FaceAuth) ensures the authenticity of applicants and aids in deduplication with other scholarship portals. NSP provides a Common Standard Application Form for all schemes, simplifying the submission process. Through the Student Dashboard, students can track their application status and receive SMS updates, while the Grievance Redressal System and Helpdesk enhance user support. Integration with Common Service Centres (CSCs) enables students to complete OTR and form submissions at nominal charges.

As of now, NSP has disbursed about 7.33 crore scholarships amounting to around Rs. 44,500 crore. The funds are disbursed directly into the beneficiaries' accounts through the Direct Benefit Transfer (DBT) mechanism by the scheme owning Ministry/Department.

#### 2.5.4.4 Schemes and Welfare Program Management

The PM POSHAN Portal (<https://pmposhan.education.gov.in>) built for the PM POSHAN (Pradhan Mantri Poshan Shakti Nirman) scheme which aims to provide hot cooked meals to 11.80 crore children in 11.20 lakh government and government-aided schools from 2021-2026. Key digital platforms <https://pmposhan-ams.education.gov.in>, and <https://pmposhan-mis.education.gov.in>, ensure real-time monitoring of meal distribution, data visualization, and reporting across schools and UTs.

#### PM SHRI application (<https://pmsfri.education.gov.in>)

The PM SHRI scheme aims to identify, select, and efficiently manage over 14,500 model schools across India, with the goal of providing a nurturing and high-quality learning environment for more than 20 lakh students. To achieve this, the scheme leverages the Prabandh Portal (<https://prabandh.education.gov.in/pmsfri>), a centralized digital platform that facilitates the streamlined management of all financial and administrative activities. The portal ensures accuracy and transparency of data, enables real-time monitoring through interactive dashboards, and supports evidence-based decision-making.

#### Vidyanjali (<https://vidyanjali.education.gov.in>)

The Vidyanjali is a government initiative that connects volunteers and organizations with schools across India to strengthen the education ecosystem. It enables contributions in the form of knowledge, skills, assets, and learning materials, fostering community and corporate participation. The platform includes real-time dashboards and streamlines CSR project and Adoption modules to ensure transparent, efficient, and impactful engagement with schools.

#### Online Teaching, Learning and Assessment System (OTLAS) (<https://ullas.education.gov.in>)

The Online Teaching, Learning and Assessment System (OTLAS) is a digital platform developed by NIC under the ULLAS initiative to promote adult literacy. It empowers over 5 crore learners by providing online tools for registration, learning, assessment, and certification, in collaboration with NIOS, thereby enabling accessible and inclusive education through technology.

#### PRABANDH (Project Appraisal, Budgeting, Monitoring and Evaluation System)

##### (<https://prabandh.education.gov.in>)

PRABANDH developed by NIC for the Samagra Shiksha Scheme, is an online platform for planning, monitoring, and managing activities and funds across all States and UTs, covering pre-primary to senior secondary education. It tracks progress of activities like teacher training, infrastructure, ICT, uniforms, textbooks, and school buildings using analytical and visual reports for central, state, and district-level reviews. Integrated with UDISE+ and the DBT portal, PRABANDH ensures accurate data synchronization. Under Samagra Shiksha, ₹41,250 crore was approved for FY 2025-26 and ₹37,010 crore for FY 2024-25 for various recurring and non-recurring activities through this portal.

### 2.5.4.5 Educational Institutes Information Management

Effective information management in educational institutes is paramount for facilitating data-driven decision-making, ensuring the security and accessibility of valuable educational data.

**UDISE+ platform (<https://udiseplus.gov.in/>)** is India's largest and most comprehensive school education database. It serves as a unified digital platform for collecting, managing, and analysing data related to school education across the country. Covering over 14.71 lakh schools, 24.69 crore students, and 1.01 crore teachers, UDISE+ provides a robust foundation for evidence-based planning, monitoring, and policy formulation in the education sector.

**Performance Grading Index (PGI) (<https://pgi.udiseplus.gov.in/>)** is a nationwide framework developed by the Ministry of Education to assess and improve the quality of school education across India. Covering 1.47 million schools, 10.1 million teachers, and 246.9 million students, it evaluates states and UTs on parameters like learning outcomes, access, equity, infrastructure, and governance, promoting data-driven policy decisions and continuous improvement.

**All India Survey on Higher Education (AISHE) platform (<https://aishe.gov.in>)** is the primary source of comprehensive data on higher education in India. It covers all Universities, Colleges, and Standalone Institutes, collecting information from over 70,000 HEIs through an online Data Capture Format (DCF) on parameters such as teachers, enrolment, programmes, results, accreditation, finance, NEP, and infrastructure.

**PM-USHA Portal (<https://pmusha.education.gov.in>)** by NIC is integrated with AISHE and PM Gati Shakti portals. It enables online proposal evaluation, project monitoring, and serves as a comprehensive MIS, ensuring end-to-end automation—from proposal submission to PAB approval for an efficient, transparent, and user-friendly experience.

**National Task Force (NTF) – Mental Health Portal (<https://ntf.education.gov.in>)** the Honourable Supreme Court of India has constituted a National Task Force (NTF) to address mental health challenges among students in higher education institutions. NIC has been entrusted with the responsibility to design, develop, and host the NTF–Mental Health Portal, and to conduct an online survey through this platform.

### 2.5.4.6 Educational Products and Solutions

**CollabGEO (<https://collabgeo.nic.in>)** is an indigenous web-based collaborative 2D geometry tool that enriches the teaching and learning of geometry concepts in Indian schools, aligning with NCERT curricula for classes 6th to 10th, with features like geometry creation, annotations, measurements, real-time collaboration, and more, aiming to improve math education. This application has been onboarded to DIKSHA Portal.

**CollabCAD (<https://collabcad.gov.in>)** is a 3D/2D Engineering Drawing Software system, for the education sector available on desktop and collaborative network enabled systems benefiting CBSE affiliated schools' students studying engineering graphics in class XI-XII. A web-based 3D viewer platform is also available for students and academicians to visualize 3D digital models directly over modern web-browsers without installing any software or plugins.

## 2.5.5 e-Transport

### 2.5.5.1 About eTransport MMP

eTransport Mission Mode Project (eTransport MMP), led by the Ministry of Road Transport and Highways (MoRTH) and implemented by NIC, is a key digital initiative to digitize transport services across India. It covers vehicle registration, driving licenses, enforcement, road safety, and taxation, permits, and fitness certification — improving efficiency, transparency, and citizen access.

### 2.5.5.2 eTransport Ecosystem

The eTransport project integrates the entire vehicle lifecycle—from manufacturing and registration to fitness, insurance, and scrapping. Flagship platforms Vahan, Sarathi, and eChallan provide centralized, web-based services across all States and UTs, while supporting applications like NextGen mParivahan, eChallan, mVahan and PUC enhance citizen service delivery and enforcement efficiency.

The project offers a comprehensive suite of G2G, G2B, and G2C services, benefiting citizens, businesses, and government agencies. It seamlessly connects stakeholders across domains including manufacturers, dealers, banks, FASTag, eWay Bill, Smart Cities, Pollution and Fitness Centers, Driving Schools, GST, and enforcement bodies. At its core, the National Register enables real-time access to over 40 crore vehicle and 22 crore driving license records, underscoring its pivotal role in India's digital transport ecosystem.

### 2.5.5.3 Integration of e-CHALLAN with Intelligent Traffic Management System (ITMS)

The eChallan system is a unified, nationwide digital traffic enforcement solution under the “One Nation, One Challan” initiative. It includes an Android-based mobile application and a web portal and is currently implemented across 33 states and Union Territories. Developed to streamline operations for Transport Enforcement Officers and Traffic Police, it offers a comprehensive, transparent, and efficient platform for managing traffic violations. Integrated with Vahan and Sarathi, eChallan provides digital interfaces for all key stakeholders, including MoRTH, State Transport Departments, Police, Courts, and Citizens. It enables online challan issuance, real-time offense tracking, digital receipts, and cashless fine payments. Over 37.6 crore e-Challans have been issued.

In addition, 25 States/UTs and smart cities have implemented the Intelligent Traffic Management System (ITMS), incorporating advanced technologies like CCTV cameras, Automatic Number Plate Recognition (ANPR), Speed Guns, Over-Speed Violation Detection (OSVD), and Red-Light Violation Detection (RLVD) devices to monitor traffic violations effectively. The data from these systems is integrated with eChallan to issue violation notices seamlessly. Over 11.55 crore traffic violation notices have been issued through this system.

The system also integrates with the e-Detection Application, Lok Adalat, and Virtual Courts, while providing an online portal for citizens to view and pay challans.

### 2.5.5.4 Integrated Road Accident Database (iRAD)

The Electronic Detailed Accident Report (eDAR) developed as an advanced extension of the Integrated Road Accident Database (iRAD), eDAR is designed to enhance transparency, speed, and accuracy in the handling of road accident cases.

By enabling real-time, on-site reporting, eDAR seamlessly integrates with a structured workflow for claims and compensation, facilitating cashless claims processing. Validated accident data, captured and shared by police authorities, is accessible to hospitals, insurance providers, and judicial bodies—ensuring prompt medical assistance, expedited compensation, and timely relief for victims, while significantly reducing the risk of fraudulent claims.

### 2.5.5.5 NextGen mParivahan App

NextGen mParivahan is the mobile extension of Vahan, Sarathi, and other eTransport components, available on Android and iOS. This citizen-centric app provides access to 75+ transport-related services and has been downloaded by more than 12.5 crore users. Key features include virtual RC and DL, real-time vehicle verification, eChallan and PUC status checks, and a grievance redressal system. Additionally, it empowers citizens to report accident details in real time, including images, geolocation, and contextual information, enriching the national accident database and enhancing emergency response.

### 2.5.5.6 Sale and Purchase of Pre-Owned Vehicles (Dealer Authorization Certificate (DAUC))

The Dealer Authorization Certificate is issued to vehicle dealers in India as proof of their authorization by the Regional Transport Office (RTO) to sell pre-owned vehicles. This certification promotes transparency in the sale and purchase of registered vehicles through authorized dealers, supported by a comprehensive regulatory framework for the pre-owned car market. Dealers are empowered to apply for various services, such as renewing registration certificates, obtaining duplicate certificates, renewing certificates of fitness, transferring ownership, and applying for No Objection Certificates (NOCs) for vehicles in their possession.

### 2.5.5.7 National Permit and All India Tourist Permit (AITP)

The “All India Tourist Permit” (AITP), issued by the Transport Authority, allows tourist vehicle operators or owners to transport tourists, along with their personal luggage, throughout India upon payment of the permit fee. This permit enables operators to move freely across state borders without needing to pay additional fees at each checkpoint. The new system introduces a fully online, time-bound application process, with permits to be granted within 7 days.

### 2.5.5.8 Pollution Under Control Certificate (PUCC)

The Pollution Under Control Certificate (PUCC) is a web and mobile-based platform designed to automate the operations of Pollution Under Control (PUC) Centres across India. It enables the efficient issuance of certificates to vehicles that meet required emission standards and updates the national database on compliant and non-compliant vehicles. Currently, 31 states have implemented the PUCC system, with over 37 crore certificates issued across 48,628 PUC Centres nationwide.

### 2.5.5.9 Registered Vehicle Scrapping Facility (RVSF) application.

As per GSR 653(E), the Registered Vehicle Scrapping Facility (RVSF) application has been developed to help vehicle owners easily phase out old and unfit vehicles that contribute to high emissions and poor air quality. RVSFs are being set up to make the scrapping process in India more organized, transparent, and environmentally friendly. To ensure convenience for citizens, vehicles registered in any state can be scrapped at any RVSF across the country.

### 2.5.5.10 mVahan mobile App

mVahan is designed as a convenient mobile solution tailored for Departmental Officers at RTOs and internal stakeholders such as Dealers in India. Currently available on the Android platform, it streamlines a range of Vahan Services, including automating Vehicle Inspection and Fitness processes. The app also facilitates seamless document uploads by Dealers and RTOs during vehicle registration, enhancing efficiency and reducing paperwork. Additionally, mVahan supports services like processing requests for Change of Address, further simplifying administrative tasks within the transport sector.

### 2.5.5.11 Automatic Fitness Management System (AFMS)

The Automatic Fitness Management System (AFMS) is an initiative to modernize vehicle fitness management in India. It allows vehicle owners to book fitness check appointments online at any Automated Testing Station (ATS) across the country, regardless of the vehicle's state of registration. The system enhances convenience by enabling access to fitness services without geographical limitations, providing digital fitness reports, and facilitating re-test applications when needed. Around 130 such centres are currently operational across 12 States/UTs.

### 2.5.5.12 Vehicle Location Tracking Device (VLTD)

The Vehicle Location Tracking Device (VLTD) application simplifies the approval and installation of tracking devices and panic buttons in public service vehicles. Integrated with Vahan, it enables real-time vehicle tracking, enhancing safety, regulatory compliance, and operational efficiency, especially for commercial fleets.

### 2.5.5.13 Homologation

The Homologation application streamlines the process of obtaining Type Approval for vehicles before they enter the market. Integrated with the Vahan Database, it ensures efficient execution of the approval process.

## 2.5.6 Inclusive Development

### 2.5.6.1 Mahatma Gandhi National Rural Employment Guarantee Act (MGNREGA) <https://nrega.dord.gov.in>

Mahatma Gandhi National Rural Employment Guarantee Act (MGNREGA) is a demand-driven program ensuring up to 100 days of wage employment per rural household annually, aimed at enhancing livelihood security and building durable rural assets. In FY 2024–25, the scheme generated over 286 crore person-days of employment nationwide. Its core focus areas include asset creation (water harvesting, land development, rural roads, plantations), wage disbursement, and citizen entitlements such as job cards, social audits, and grievance redressal mechanisms.

- **NREGASoft – End-to-End Workflow Platform:** central e-Governance platform used across all levels — Centre, States, Districts, Blocks, and Gram Panchayats — to manage the complete workflow from job card issuance and work planning to e-muster generation, wage lists, and payment file creation.
- **e-FMS, e-Muster & DBT Integration:** to ensure timely, transparent wage disbursement and centralized payment reconciliation.
- **NMMS Application:** NMMS app, enables real-time, geo-tagged attendance through twice-daily photographs of workers at MGNREGA worksites.
- **Data & Public Dashboards:** provide state, district, and GP-level dashboards, downloadable reports, and public access to muster rolls, fund flows, and work details.

### 2.5.6.2 Jal Jeevan Mission (JJM) <https://jaljeevanmission.gov.in/>

The Jal Jeevan Mission Portal is the official digital platform of a large-scale Government of India initiative aimed at providing safe and adequate drinking water to every rural household in India. The portal hosts program details, implementation status, guidelines, media coverage, success stories, and regular updates.

### 2.5.6.3 Swachh Bharat Mission-Grameen (SBM-G) <https://swachhbharatmission.ddws.gov.in/>

The Swachh Bharat Mission–Grameen (SBM(G)) web portal is a comprehensive digital platform for monitoring, managing, and tracking Government of India’s flagship initiative of sanitation in rural sector. This helps to monitor Solid & Liquid Waste Management to ensure better sanitation and to promote construction of toilets in rural India.

### 2.5.6.4 Pradhan Mantri Awaas Yojana – Gramin (PMAY-G) <https://pmayg.dord.gov.in>

The PMAY-G scheme aims to provide pucca houses to rural families living in kutcha or dilapidated homes, advancing the vision of Housing for All. To strengthen implementation, NIC developed key digital platforms — AwaasSoft, AwaasPlus, and the AwaasPlus 2024 mobile app, enabling seamless data collection, beneficiary verification, and real-time monitoring.

### 2.5.6.5 National Social Assistance Programme (NSAP) <https://nsap.nic.in>

National Social Assistance Programme (NSAP), a 100% Centrally Sponsored Scheme under the Ministry of Rural Development (MoRD), provides financial and food security assistance to the elderly, widows, and persons with severe disabilities from Below Poverty Line (BPL) families. It leverages the NIC's NSAP-PPS (Payment Processing System) platform for online registration, verification, approval, and integration with UIDAI, PFMS, India Post, and NIC's SMS Gateway. It integrates Digital Life Certificates for real-time verification and uses Aadhaar-based validation, PFMS integration, and automated audit trails to ensure transparency. The portal supports 23 Indian languages via Bhashini and features real-time dashboards for data-driven monitoring and decision-making.

### 2.5.6.6 Senior Citizen portal (<https://scw.dosje.gov.in>)

Senior Citizen Services Portal for the Ministry of Social Justice and Empowerment is a single digital platform for accessing key services, schemes, and information for welfare of senior citizens. The portal integrates with National Career Service (NCS) for employment opportunities, ARJUN for assistive devices under RVY, and the National Helpline for Senior Citizens Elderline (14567) helpline for support and grievance redressal.

### 2.5.6.7 Nasha Mukht Bharat Abhiyaan (NMBA)

The NMBA portal was developed to provide campaign outreach information through an integrated dashboard. NIC-DoSJE now manages and enhances this portal. It is connected with the NMBA Survey App and displays NMBA, ATF, and GIA dashboards. The portal also enables citizens to take the "Say No to Drugs" pledge.

### 2.5.6.8 Bal Vivah Mukht Bharat (BVMB) / Stop Child Marriage Portal <https://stopchildmarriage.wcd.gov.in>

The Bal Vivah Mukht Bharat (BVMB) Portal, developed by NIC for the Ministry of Women & Child Development, is a central digital platform to prevent and monitor child marriage across the country. The portal enables real-time reporting, verification, and action on suspected cases through a structured workflow connecting officials from Gram Panchayat to the National level.

### 2.5.6.9 Mission Shakti <https://missionshakti.wcd.gov.in>

The Mission Shakti Portal, designed and developed by NIC for the Ministry of Women & Child Development, is an integrated digital platform that centrally manages services and interventions aimed at women's safety, security, and empowerment across India. It brings together key components of the Sambal and Samarthya sub-schemes—including One Stop Centres, Women Helpline 181, Nari Adalats, Shakti Sadan, and Sakhi Niwas—into a unified workflow-based system accessible to citizens and officials.

### 2.5.6.10 Mission Vatsalya Portal (<https://missionvatsalya.wcd.gov.in>)

The Mission Vatsalya Portal, developed by NIC, is a unified digital ecosystem designed to deliver timely and coordinated services to Children in Need of Care and Protection and Children in Conflict with Law. Covering 26 categories of vulnerable children, the portal integrates key stakeholders—including Child Welfare Committees, District Magistrates, Juvenile Justice Boards, Police units, Child Care Institutions, foster families, and bodies like SARA and CARA—into a single workflow-based platform. By digitizing nearly 50 forms of the Juvenile Justice System and streamlining workflows for services such as foster care, sponsorship, adoption, Khoya-Paya, and institutional care, it eliminates communication gaps, reduces delays, and ensures consistent case management.

#### 2.5.6.11 PM CARES for Children Portal (<https://pmcaresforchildren.in>)

The PM CARES for Children Portal, developed by NIC for the Ministry of Women & Child Development, is a unified digital platform that enables end-to-end identification, verification, and monitoring of children who lost parental care due to COVID-19. The portal supports authorities across all States and UTs through a workflow-based system that digitizes the entire lifecycle of each beneficiary up to 23 years of age, covering financial assistance, education support, health coverage, and care arrangements.

#### 2.5.6.12 Pradhan Mantri Matru Vandana Yojana (PMMVY) (<https://pmmvy.wcd.gov.in/>)

The PMMVY Portal, developed and maintained by NIC, is a unified digital platform that enables end-to-end administration of the Pradhan Mantri Matru Vandana Yojana, a maternity benefit scheme providing conditional cash transfers to pregnant and lactating women for their first child and second girl child. The portal supports seamless beneficiary registration, Aadhaar-based authentication, PFMS-linked DBT payments, and real-time monitoring across all States and UTs.

#### 2.5.6.13 SHe-Box (Sexual Harassment electronic Box) (<https://shebox.wcd.gov.in>)

The SHe-Box Portal, developed by NIC for the Ministry of Women & Child Development, is a unified digital platform that enables women in both government and private sectors to securely file and track workplace sexual harassment complaints under the POSH Act, 2013.

The portal provides an end-to-end grievance management workflow—covering complaint submission, status tracking, communication with Internal Committees, and escalation—while ensuring confidentiality, transparency, and timely redressal. It supports large-scale onboarding of Central and State Departments, District and Local Committees, and private organizations, offering role-based access for administrators, nodal officers, and IC members.

### 2.5.7 Consumer Affairs and Food & Public Distribution

#### 2.5.7.1 CONFONET

The scheme of ‘Computerization and Computer Networking of Consumer Fora in the country, (CONFONET)’ aims to digitalize the functioning of the Consumer Commissions at all the three tiers throughout the country. The registration of complaints, recording of court proceedings, issue of notices, generation of cause lists, recording of judgements, record-keeping, and generation of statistical reports etc. are carried out through Online Case Monitoring application software.

#### 2.5.7.2 eDaakhil (<https://edaakhil.nic.in>)

As an initiative of the Department of Consumer Affairs, a web-based application software named “eDaakhil” has been developed by NIC. The portal empowers the consumers who have any grievance w.r.t any deficiency in services or quality of Goods.

#### 2.5.7.3 Targeted Public Distribution System

The scheme “End-to-End Computerization of Targeted Public Distribution System (TPDS) Operations” aims to modernize the TPDS operations and to bring transparency in the distribution of highly subsidized food grains across the country. The System is operated under the shared responsibility of the Central and the State Governments.

- Digitization of ration cards/beneficiary database for correct identification of beneficiaries; removal of bogus cards and better targeting of food subsidies.

- Online allocation of food grains for system-generated allocation orders to bring transparency in allocation of food grains, up to the Fair Price Shops level.
- Computerization of Supply Chain Management to ensure timely availability of food grains at all FPSs for delivery to the targeted beneficiaries and to check leakage/diversion of food grains.
- Online Grievance Redressal / Toll-Free Helplines and Transparency Portals to introduce transparency and public accountability in the implementation of TPDS.

#### 2.5.7.4 SMART –PDS

SMART-PDS is an advanced digital platform aimed at enhancing transparency, efficiency, and accountability in the Public Distribution System (PDS) across the country. The system has been architected to provide a unified, scalable, and secure platform for managing key processes in the PDS value chain — from Ration Card Management to Procurement, Supply Chain, Allocation, and Distribution.

#### 2.5.7.5 One Nation One Ration Card (ONORC)

One Nation One Ration Card is a national Ration Card portability scheme to ensure food security for all including internal migrants within India. It enables migrant workers and their family members to access PDS benefits from any Fair Price Shop anywhere in the country, thus ensuring food security through the inter-state portability of ration cards.

#### 2.5.7.6 Subsidy Claims Application for NFSA (SCAN) (<https://nfsa.gov.in>)

SCAN Portal facilitates the management and disbursement of food subsidies under the National Food Security Act (NFSA) and other welfare schemes. It ensures streamlined processing for all subsidy-related claims under the Public Distribution Systems for Government of India & State Governments. The SCAN Portal's integration with the Public Financial Management System (PFMS) ensures automated and error-free fund disbursements directly to state food department accounts and FCI.

#### 2.5.7.7 Mera Ration mobile application

The Mera Ration mobile application, developed by the Department of Food and Public Distribution, is a citizen-centric tool under the One Nation One Ration Card (ONORC) initiative. It provides key digital services to beneficiaries of the National Food Security Act (NFSA) such as Ration Card Services, Real-Time Information Access, Nearby FPS Locator, Grievance Redressal, and FPS Rating System.

#### 2.5.7.8 Anna Mitra Mobile Application

Anna Mitra is an official mobile application developed by the Department of Food and Public Distribution, Government of India, for enabling PDS officials and stakeholders to access Public Distribution System (PDS) information anywhere, anytime in India.

The app is designed exclusively for FPS Dealers, District Food Supply Officers (DFSO), and Food Inspectors, providing them with a unified platform to view ration-related data and reports in real time.

#### 2.5.7.9 Grievance Module (Central Grievance Redressal System)

Multiple grievance channels such as Anna Sahayata, Mera Ration App, CPGRAMS, INGRAM, and various State Grievance Portals, currently function in silos, leading to fragmented handling and delays in resolution. To address this, the SMART-PDS Central Grievance Management System aims to integrate these external platforms and establish a unified, streamlined, and efficient grievance redressal mechanism at the pan-India level.

## 2.5.8 Law & Justice

### 2.5.8.1 eGovernance Support to Supreme Court (<https://sci.gov.in>)

eGovernance support to the Supreme Court includes the management and enhancement of citizen- and litigant-centric digital services such as the official website, which provides access to Cause Lists, Case Status, Daily Orders, Judgements, Vernacular Judgements, and the e-Copying facility.

E-Filing 2.0 system has streamlined electronic filing by enabling defect notification, defect rectification, and efficient document processing for all stakeholders, including Advocates-on-Record, Parties-in-Person, and the Registry. Work-from-Anywhere (e-Office) module has significantly reduced paper dependency and physical workstation constraints, thereby enhancing operational convenience and efficiency for the Registry.

SuSwagatam, a citizen-centric, web-based, and mobile-friendly application, enables visitors to the Supreme Court to request e-Passes online, eliminating the need for long queues at the premises. The official Supreme Court of India mobile application, developed in-house by the NIC team at SCI, continues to function seamlessly, providing the Hon'ble Chief Justice of India, Hon'ble Judges, advocates, litigants, Ministries, Departments, and journalists access to live streaming of court proceedings.

### 2.5.8.2 Tribunals, Regulatory Bodies and Commercial Courts

Online Tribunals System of NIC is an ICT enabled initiative towards digital transformation of processes, workflows followed in tribunals through process re-engineering and providing a configurable automated system to cater needs of all its direct and in-direct stakeholders. It implements a decision support and case management platform for Tribunals to ensure speedy, transparent, and reliable justice delivery. It enables end-to-end online services including e-Filing Case Information System (CIS), Document Management System (DMS) and eHearing (through VC).

### 2.5.8.3 eCourts

eCourts, a Mission Mode Project of the Government of India, was conceptualized by eCommittee, Supreme Court of India, with a vision to transform the Indian judiciary by ICT enablement of courts. Phase III of the eCourts project, initiated in 2023, envisions a judicial system that is more affordable, accessible, cost-effective, predictable, reliable, and transparent for every individual who seeks justice or is part of the delivery of justice in India.

### 2.5.8.4 Case Information System (CIS), Application for Indian Judiciary (<https://ecourts.gov.in>)

Case Information System (CIS) application is implemented in High Courts and District & Subordinate courts of the country. Currently CIS version 4.0 is implemented in 8166 District & Subordinate courts and CIS HC Version 1.0 is implemented in 22 High Courts in the country.

### 2.5.8.5 National Judicial Data Grid (<http://njdg.ecourts.gov.in>)

National Judicial Data Grid is a consolidated nationwide judicial data warehouse which was set up with real time updates. NJDG provides statistics of pending and disposed cases in the country. It works as a monitoring tool to identify and manage the pendency of cases. NJDG currently hosts data of 25 Crore cases (pending and disposed) from District and Taluka Courts and 4.9 Crore cases from High Courts.

### 2.5.8.6 Virtual Courts

The concept of Virtual Courts is aimed at reducing footfalls in the courts by eliminating the physical presence of traffic violators or advocates in the court. Virtual Court is integrated with the eChallan application of the eTransport project. eChallans are digitally shared with Virtual Court for its further adjudication. A virtual judge can preside over a Virtual

Court whose jurisdiction can be extended to the entire state and working hours may be 24x7. Neither litigant needs to visit the court nor judge will have to physically preside over the court, thus saving precious judicial time. Till date 8.9 crore challans have been received through the Virtual Court, with proceedings completed for 7.8 crore challans, resulting in the collection of fines exceeding INR 896 crore.

#### 2.5.8.7 ePay (<https://pay.ecourts.gov.in>)

ePay is developed as a single payment gateway for the payment of various kinds of digital payments in the courts. It enables payment of court fees, judicial deposits, fine, penalty and other fees online through the ePay portal, thereby eliminating the use of stamps, cheque, and cash. ePay portal is integrated with 36 different State treasury applications like SBI ePay, GRAS, eGRAS, JeGRAS, Himkosh, Rajkosh etc. used by respective State Governments.

Till date amount of more than INR 1,227 crore is collected from 51 lakh transactions through ePay.

#### 2.5.8.8 eFiling (<https://filing.ecourts.gov.in/pdedev/>)

eFiling 3.0 system is a complete end to end solution developed for online filing of complaints, written statements, replies, and various applications related to cases. Both Civil and Criminal cases can be filed before any High Court or District Court of the country. The system is designed in Bilingual (English and local language) to reach wider group covering advocates/litigants.

Currently the system is operational in 30 States and more than 74 Lakh cases have been filed online through eFiling portal.

#### 2.5.8.9 NSTEP

NSTEP provides a Centralized process service tracking application and a bilingual mobile app for court messengers designed and developed for online delivery of court processes in Civil cases. It reduces inordinate delays in process serving. New enhancement for sharing of criminal warrants/ summons with ICJS/CCTNS application has also been introduced. More than 1 Crore processes have been delivered through NSTEP till date.

#### 2.5.8.10 JustIS App

JustIS mobile app is provided to Judicial officers to monitor pendency and disposal at fingertips. It also includes several new features like "Briefcase" to view the disposal of cases during previous postings. Principal District Judge can monitor pendency and disposal of the entire district under the jurisdiction and for individual judges.

#### 2.5.8.11 Judgment Search Portal (<https://judgments.ecourts.gov.in> and <https://scr.sci.gov.in>)

The Judgment Search Portal allows users to search judgments from the High Courts using various parameters such as case type, act, judge, and decision date etc. eSCR provide facility to search Supreme Court judgments. Facility of free text search is available in both the portals.

More than 1.68 Crore judgments from across 25 high courts and 37,657 judgments from the Supreme Court of India are currently available.

#### 2.5.8.12 Digital Courts

Digital Courts, Green Initiative of Indian Judiciary, has been developed to make courts paperless/ digital. The web app provides a facility for Judges to view all the case-related pleadings, charge sheets, court orders etc. of both civil and criminal cases which aim at making the court paperless. It provides AI (Artificial Intelligence) based facilities -

Automatic Speech Recognition (ASR) facility for converting speech to text to generate judgements and Translation facility for translating judgments in 18 different languages. Case Information System (CIS), eFiling, JustIS Mobile App and Interoperable Criminal Justice System (ICJS) are integrated with Digital Courts.

#### 2.5.8.13 Virtual Justice Clock for District Judiciary of India

Virtual Justice Clock for District Judiciary of India is a real time informative public dashboard which provides information in 3 levels covering all the States, Districts, and Court Establishments. Justice Clock displays statistics of Institution, Disposal and Case Clearance Rate of the State, District and Court Establishment. It also displays total pendency of cases age wise and number of cases listed for hearing on a given day.

#### 2.5.8.14 Integration with Interoperable Criminal Justice System (ICJS)

Inter-operable Criminal Justice System (ICJS) aims at integrating Crime and Criminals Tracking Network and Systems (CCTNS), e-Courts, and e-Prisons databases. CCTNS shares FIR and charge sheet data in electronic form to eCourts application, whereas eCourts shares CNR number and case details to the CCTNS through ICJS. Further updates about the case are made available through APIs.

eCourts also shares Criminal Summons/Warrant with ICJS/CCTNS through eCourts APIs. In return ICJS/CCTNS shares delivery status of Summons/Warrant online.

### 2.5.9 Home Affairs

#### 2.5.9.1 Interoperable Criminal Justice System (ICJS)

The Interoperable Criminal Justice System (ICJS) is a unified digital platform that enables seamless data exchange across CCTNS, e-Courts, e-Prisons, e-Forensics, e-Prosecution, Fingerprint, MedLEaPR, CrPI, and Women & Child-related systems. Built on the principle of “One Data, One Entry,” it ensures data consistency, eliminates duplication, and supports faster decision-making across the criminal justice ecosystem.

Developed and supported by NIC, ICJS provides an interoperable API suite, a national big data repository, advanced analytical dashboards, 360-degree profiling of criminals, criminal network analysis, and intelligence tools for quick identification of repeat offenders and crime patterns. Integrated dashboards such as NDSO, ITSSO, POCSO, NIDAAN, NDOFO, NDHT, and IMOT enable real-time monitoring and stronger coordination among police, courts, prisons, prosecution, and forensics.

#### 2.5.9.2 eSakshya

eSakshya is a national digital platform designed for secure recording, management, and verification of primary digital evidence under the new criminal laws. The platform ensures tamper-proof storage through encrypted evidence lockers, automatic hash generation, and controlled access for authorized police and judicial officers via ICJS-based multi-factor authentication. Developed and implemented by NIC, eSakshya is now operational across 35 States/UTs, supporting seamless onboarding and nationwide usage. Its integrated Sakshya Viewer enables courts, prosecutors, and investigators to access verified evidence efficiently, resulting in faster charge-sheet preparation and enhanced transparency in investigations.

#### 2.5.9.3 eSummons <https://icjs.gov.in/esummons>

The eSummon System, comprising a unified portal and mobile application, digitizes the entire lifecycle of judicial summons, enabling Courts to generate, route, and track summons electronically while Delivery Officers update service

attempts through geo-tagged mobile submissions. The system has reduced delays in summons service, improved jurisdiction accuracy for Police, and strengthened accountability through GPS-tagged proofs and real-time monitoring.

#### 2.5.9.4 Indian Cybercrime Coordination Centre (I4C) (<https://cybercrime.gov.in>)

Indian Cybercrime Coordination Centre (I4C) is an initiative of the Ministry of Home Affairs, Government of India to deal with cybercrime in the country in a coordinated and comprehensive manner. I4C focuses on tackling all the issues related to Cybercrime for the citizens, which includes improving coordination between various Law Enforcement Agencies and the stakeholders, driving change in India's overall capability to tackle Cybercrime and to improve citizen satisfaction levels. Portals include:

- **National Cybercrime Reporting Portal (<https://cybercrime.gov.in>):** For citizens to report and track their Cybercrime complaints.
- **National Cyber Police Portal (<https://cyberpolice.nic.in>):** Backend portal for MHA, DoT, IB, CBI, TSPs, LEAs and financial intermediaries to process the complaints. This Portal has multiple stakeholders like All India State/ District/ Police Station LEAs, Banks/ Financial Intermediaries, Department of Telecom, States LSA, TSP and other central agencies.
- Sahyog Portal has been developed to automate the process of sending notices to intermediaries by the Appropriate Government or its agency under IT Act, 2000 to facilitate the removal or disabling of access to any information, data or communication link being used to commit an unlawful act.

#### 2.5.9.5 ePrisons

The ePrisons application is a centralized prison management system covering the entire lifecycle of prisoners—from admission to release. Implemented across 1380 jails nationwide, it manages data of over 2.2 crore prisoners, with 5,33,912 inmates currently inside, and facilitates coordination among Prison, Police, Courts, Home Departments, and Legal Authorities.

#### 2.5.9.6 Citizen Service

The Citizen Services allows registered relatives of prisoners to view prisoner profiles, submit eMulakat (online meeting) and parole requests, and lodge grievances through the national ePrisons portal. It enhances transparency, efficiency, and communication between prisoners' families and prison authorities under the Digital India initiative.

### 2.5.10 Culture and Tourism

#### 2.5.10.1 Tourism

**Key ICT activities initiated by the collaborative efforts of NIC and Ministry of Tourism:**

- **NIDHI Plus National Integrated Database of Hospitality Industry (<https://nidhi.tourism.gov.in>)**  
NIDHI Plus is a comprehensive digital platform developed for the Ministry of Tourism to create a robust database of India's hospitality sector. It includes hotels, resorts, B&Bs, homestays, travel trade service providers, and other allied units. The system enables registration, authentication, and integration of hospitality service providers to enhance transparency and quality standards in tourism services.
- **Utsav- India's Cultural Events & Festivals Platform (<https://utsav.gov.in>)**  
A digital platform showcasing festivals, fairs, and cultural events across India. Promotes regional diversity, enhances cultural tourism, and allows citizens and tourists to discover upcoming events easily.

### 2.5.10.2 Culture Informatics

#### Amritkaal Portal (formerly Azadi Ka Amrit Mahotsav) <https://amritkaal.nic.in>

Azadi Ka Amrit Mahotsav, marking 75 years of India's independence, is supported by the Amritkaal portal engaging ministries, states, local bodies, and the citizens. Various campaigns are on the lines of themes aligned with the 'Panch Pran' announced by Hon'ble Prime Minister. The portal was relaunched on 25th June 2025 to document Emergency-era narratives.

### 2.5.11 Labor & Employment

#### 2.5.11.1 National Database of Unorganized Workers (eShram Portal)

NIC has developed an e-Shram portal for creating Aadhaar authenticated comprehensive NDUW. The portal has details of the Unorganized workers such as Name, Mobile Number, Occupation, Address, Aadhaar seeded Bank name, Educational Qualification, Skill types etc. It is the first-ever national database of Unorganized workers. More than 31.25 Crore eShram cards have been issued since the launch of the portal.

#### 2.5.11.2 Unified Shram Suvidha Platform (USSP)

USSP portal facilitates the Ministry of Labor & Employment and its Labour Law Enforcement Agencies like EPFO, ESIC, CLC(C) and DGMS to monitor the implementation of Labor laws in various establishments in the central Government sphere. It facilitates the employer/establishment to file common registration, filing of annual returns under 8 Labor Laws along with online common Return under Mines Act of DGMS. Unique Labour Identification Number (LIN) is allotted to each establishment registered under any Labour law after deduplication of data coming from various enforcement agencies.

#### 2.5.11.3 Platform for Effective Enforcement for No Child Labor (PENCiL)

PENCiL portal connects the Ministry of Labor & Employment with 21 States, 280 Districts Project Societies with 3,400 (approx.) Special Training Centers (STCs) for effective enforcement for "No Child Labor". It sets baselines based on KPIs at the levels to monitor physical and financial progress reports. The platform captures children identified and rehabilitated through STCs and skill development depending on age group and nature of industry from where the children have been rescued.

#### 2.5.11.4 SAMADHAN Portal

SAMADHAN Portal is a digital initiative of the Ministry of Labor and Employment, SAMADHAN portal and it facilitates workmen, trade union, or management to raise an industrial dispute, Claims and General Complaints before the Conciliation Officer (CO) of the area.

#### 2.5.11.5 National Career Service Centre for SC/STs Portal

The National Career Service Centres (NCSCs) for Scheduled Castes and Scheduled Tribes (erstwhile NCSC) comes under Directorate General of Employment (DGE) which operate six courses, namely Special Coaching Scheme, Computer O Level Training, Computer Hardware Maintenance Training, Office Automation Accounting Publishing Assistant, Business Accounting Associate and Cyber Secured Web Development Associate. The portal supports the process flow from filling up the application form by beneficiaries till the monthly stipend being disbursed via DBT through PFMS portal based on eligibility criteria.

## 2.5.12 New & Renewable Energy

### 2.5.12.1 National Portal for PM – Suryaghar: Muft Bijli Yojna (<https://pmsuryaghar.gov.in/>)

National Portal for PM – Suryaghar: Muft Bijli Yojna aimed at installing rooftop solar plants in 1 crore households. The scheme is implemented through National Portal with main stakeholders as MNRE Solar Division, DISCOMs, SNAs, SECI, PSUs, Government Agencies, Vendor, and Beneficiary. This portal facilitates beneficiaries for registration followed by submitting applications for installation. The portal has been integrated with PFMS, DBT, PRAYAS, NGO DARPAN and DISCOMs for seamless exchange of data.

### 2.5.12.2 Renewable Energy Equipment Import Monitoring System (REE-IMS) (<https://reeims.mnre.gov.in>)

The Secretary, Ministry of New and Renewable Energy (MNRE) launched Renewable Energy Equipment Import Monitoring System (REEIMS) portal by NIC to monitor the imports of renewable energy equipment in the solar and wind sectors by requiring registration before any import takes place. The REEIMS portal provides a simplified registration and application process for manufacturers and importers who can register using a valid DGFT IEC code.

### 2.5.12.3 Biogas & BioUrja Portals (<https://biogas.mnre.gov.in>) / (<https://biourja.mnre.gov.in>)

Biogas Portal for the Ministry of New & Renewable Energy (MNRE) is a central platform for beneficiaries to install small and medium biogas plants ranging from 1 cubic meter to 2,500 cubic meter.

BioUrja Portal for the Ministry of New & Renewable Energy (MNRE) is an online platform developed to assist project developers in submitting applications for plant installation and commissioning of Biomass and Waste to Energy.

## 2.5.13 Good Governance & Enforcement

### 2.5.13.1 IVFRT: Immigration, Visa, and Foreigners Registration & Tracking

The core objective of this Project is to develop and implement a secure and integrated service delivery framework that facilitates legitimate travellers while strengthening security. The scope of the project includes 200+ Indian Missions abroad, 114+ ICPs (Immigration Check Posts), 12 FRROs (Foreigners Regional Registration Offices), and 850+ FROs (Foreigners Registration Offices) in the State /District Headquarters.

The project introduced several citizen-centric services, including online Visa application submission, e-Visa service, Automated e-gates, 24x7 access to information through digital channels, phone and email-based grievance redressal, application status tracking, and feedback mechanisms.

### 2.5.13.2 e-Visa

e-Visa system is a flagship initiative by the Government of India to simplify and modernize the process of obtaining a visa for foreign nationals. It enables travellers from over 172 countries to apply for a visa online, eliminating the need to visit Indian embassies or consulates. Applicants can conveniently submit their details, upload necessary documents, and make payments through a secure online platform.

### 2.5.13.3 National eVidhan Application (NeVA) (<http://neva.gov.in>)

National eVidhan Application (NeVA), a mission-mode project by the Government of India with NIC as the technical partner, aims to digitize legislative functioning across state and UT legislatures, making processes more efficient, transparent, and paperless. Aligned with the “One Nation, One Application” vision, NeVA brings together 37 legislatures on a unified platform, enabling real-time access to agendas, bills, committee reports, debates, and proceedings for legislators, staff, and citizens.

Key features include paperless workflows, standardized processes, real-time collaboration, automated scheduling, AI-enabled multilingual translation via Bhashini, and cloud-based security on Meghraj. The platform consists of a Public Portal, Content Management System (CMS), Digital House (eBook), and Mobile Apps (iOS & Android).

NeVA has been implemented in 20 legislative houses, with several others in the pipeline. It also generates significant savings on paper (~340 Cr annually), reducing carbon footprint and supporting UN SDG 15 – Life on Earth, in line with the Government’s Vision Mission 2024.

#### 2.5.13.4 Digital Sansad (<https://www.sansad.in/>)

Digital Sansad—the “Temple of Democracy at a Click”—is an integrated web and mobile platform for Parliament, serving Members of Parliament (MPs), citizens, the Lok Sabha Secretariat, and government ministries. It provides end-to-end digital communication, enabling collaborative and transparent access to parliamentary business, linking state assemblies, councils, and central ministries to create a unified democratic digital ecosystem. The platform features customized dashboards for MPs to submit questions, bills, notices, and track attendance digitally, streamlining parliamentary processes and enhancing transparency and efficiency.

#### 2.5.13.5 Service Plus

ServicePlus is a robust and scalable platform, enabling government departments to seamlessly deliver citizen-centric services across diverse sectors. By leveraging its Low Code–No Code architecture, ServicePlus empowers even departments with limited technical expertise to configure and deploy services with minimal effort. The platform ensures interoperability, scalability, and ease of use, thereby meeting the growing demand for digital public services.

#### 2.5.13.6 Aadhaar Authentication Services

The Aadhaar Authentication Service, managed by the National Informatics Centre (NIC), serves as India’s leading digital identity verification platform, supporting over 120 Central and State government sector initiatives under the Digital India umbrella. It enables secure, real-time authentication through methods like demographics, biometric verification, OTP, and tokenisation. Aadhaar Authentication services are utilised by more than 120 Digital India projects, such as e-SHRAM, Ayushman Bharat, Public Distribution System (PDS) across 33 states and UTs in India, Digital Locker, Jeevan Pramaan, Biometric Attendance System (BAS) and more.

#### 2.5.13.7 Aadhaar Data Vault Services

NIC is providing the Centralized Aadhaar Data Vault Service to Central and State govt. schemes required to store Aadhaar numbers securely in encrypted format as per UIDAI guidelines. Aadhaar Data Vault provides storage for 36 applications like PFMS, M/o Rural Development, PMAYU, PMKISAN, PMEDRIVE, PMSVANIDHI, SSC, UPSC, NTAJEE, National Scholarship Portal, PMVIKAS, Jal Shakti Mission, M/o Health, Jeevan Pramaan, UPPDS and WBPDS to name a few.

#### 2.5.13.8 Aadhaar Enabled Biometric Attendance System (AEBAS)

(<https://attendance.gov.in>)

Digital India’s Aadhaar Enabled Biometric Attendance System - AEBAS Project was introduced for all Government employees to mark attendance conveniently anywhere in India. Any Government Employee who has an Aadhaar number can successfully register himself/herself on the portal and become a part of the system. Attendance marking initially was facilitated through 3 models – Tablets, Desktop Devices, and Iris scan machines, thus ensuring the ease of marking the attendance. Biometric is captured, authenticated via AUA/ASA and UIDAI within microseconds. The

system was enhanced with face-based Authentication attendance marking Personal Device (Android / iOS) and QR Base Face authentication.

### 2.5.13.9 E-Sign Gateway

The NIC E-Sign Gateway has been designed and developed by NIC for facilitating consumption of Aadhaar-authenticated E-Sign Services for over 400 eGov applications facilitating nearly 1 crore transactions per year. The Gateway acts as an interface for Application Service Providers (ASP) for performing Aadhaar authenticated Digital Signatures.

### 2.5.13.10 Jeevan Pramaan (<https://jeevanpramaan.gov.in/>)

Jeevan Pramaan is a digital service that allows pensioners to submit their life certificates through a biometric verification process. This service is available for pensioners of the Central Government, State Governments, and various other government organisations. Jeevan Pramaan enables pensioners to submit a life certificate from anywhere, anytime, even from home. Aadhaar-based biometric authentication is being used to ensure the aliveness of the pensioner. To further ease the way of submission of Jeevan Pramaan, Face Authentication-based Digital Life Certificate application (Android) was launched on 29th Nov 2021, and for iOS, it was launched in Nov 2024. As of now, 208 sanctioning authorities and 202 disbursing agencies have been integrated with the Jeevan Pramaan platform. These include various entities such as central and state governments, banks, Public Sector Undertakings, autonomous bodies, etc. In 2024-25, more than 1.58 Crore DLCs have been generated.

### 2.5.13.11 Web-Key Management System (KMS) for Issuance of Smart Card Based Driving License (DL)/ Registration Certificate (RC)

(<https://kms.parivahan.gov.in/DLSmartCardWeb/home>; <https://kms.parivahan.gov.in/rcsmartcardweb/home>)

The Smart Card Operating System Specification for Transport Applications (SCOSTA), developed by NIC and gazetted by the Ministry of Transport, serves as the national standard for secure and interoperable smart card issuance in India. NIC manages the production and maintenance of Authority Cards, maintains master encryption keys under the Central Key Management Authority, and develops all related software for central, state, and RTO levels. The upgraded web-based Key Management System (KMS), implemented in 14 States/UTs, automates software installation and updates, eliminates local databases, reduces redundancy, and cuts infrastructure costs. The new JSON-based layouts for DL and RC cards enhance flexibility and are available on the SCOSTA website. NIC also provides card personalization and chip-reading tools to states.

### 2.5.13.12 RTI Online Portal

RTI Online Portal, conceived and implemented by the Department of Personnel and Training (DoPT) and developed by the National Informatics Centre (NIC–DoPT), serves as a centralized platform enabling citizens to submit RTI applications and appeals electronically. The portal facilitates online registration for citizens and Non-Resident Indians (NRIs) and provides integrated payment facilities for RTI fees. The system has subsequently been extended to subordinate offices, attached organizations, public sector undertakings (PSUs), and several State Governments, including Maharashtra, Delhi, Karnataka, Uttar Pradesh, and the Union Territories of J&K, Ladakh and Andaman & Nicobar. It offers bilingual support and enables applicants to track the real-time status of their applications and appeals.

### 2.5.13.13 SNMS (Summons and Notices Management System)

The Summons and Notices Management System (SNMS), developed by NIC in collaboration with the Serious Fraud Investigation Office (SFIO), streamlines case management and issuance of summons/notices across investigation units. The system aligns with SFIO's workflow, enabling generation of investigation orders and management of case, company, and individual details through user-friendly interfaces.

# 3

## CHAPTER

# Make in India

## Electronics Manufacturing

Electronics industry is the world's largest and fastest growing industry and is increasingly finding applications in all sectors of the economy. The Government attaches high priority to electronics hardware manufacturing, and it is one of the important pillars of both "Make in India" and "Digital India" programmes of Government of India. The intent of the Government is to provide a level playing field for the domestic manufacturers, enabling them to compete with imports in the sector by rationalizing tariff structure, simplifying procedures, providing incentives and upgrading infrastructure.

### 3.1 National Policy on Electronics 2019

The National Policy on Electronics 2019 (NPE-2019) notified on 25.02.2019 envisions to position India as a global hub for Electronics System Design and Manufacturing (ESDM) by encouraging and driving capabilities in the country for developing core components, including chipsets, and creating an enabling environment for the industry to compete globally. The implementation of the schemes and initiatives under the aegis of NPE 2019 is expected to generate employment for about 10 million (1 crore) persons (Direct and Indirect) at various levels.

NPE-2019 has been formulated to reflect the new aspirations, requirements and realities of the electronics manufacturing sector in the country and the emerging international dynamics. The aim of NPE-2019 is as follows

- The NPE-2019 is focused on promoting an eco-system of manufacturing (group of industries), which forms supply chain of a product against the previous policy, which emphasized on promoting individual industries. The NPE-2019 aims to increase domestic value addition by leveraging potential of both domestic demand and export, with the goal of making India, a global hub for electronics manufacturing. The policy also promotes generation of intellectual property in India and deepening of the domestic research, development and designing capabilities.
- NPE-2019 also envisages intervention in emerging sectors of electronics like IoT, 5G equipment, sensors, drones, additive manufacturing (3D printers), robotics etc. and promotes their R&D and manufacturing. Among the sectors, Medical Electronics, Strategic Electronics, Auto & Power electronics have been especially identified as thrust areas for promoting manufacturing in India.
- The introduction of the concept of trusted value chain in electronics will help in addressing concerns related to cyber bugs and data thefts from our equipment. There is also focus on skilling, re-skilling and employment generation.
- NPE-2019 has ushered in a slew of new incentive schemes. Prominent among these are Production Linked Incentive (PLI) Scheme for Large Scale Electronics Manufacturing, PLI Scheme 2.0 for IT Hardware, Scheme for Promotion of manufacturing of Electronic Components, Semiconductors (SPECES), Electronics Manufacturing Clusters (EMC 2.0) Scheme and Electronics Component Manufacturing Scheme (ECMS).

### 3.2 Growth of Electronics Sector

Indian electronic manufacturing industry has undergone major transformation in the last couple of years with the host of initiatives and reforms. The government has taken several initiatives to promote electronics manufacturing and as a result, the domestic production of electronic goods has increased substantially from INR 6.41 lakh crore (~USD 79.11

Bn) in FY 2021-22 to INR 11.32 lakh crore in FY 2024-25 (~USD 133 Bn), growing at a Compound Annual Growth Rate - CAGR of 20.91%). The key drivers of growth are the large domestic market, availability of skilled talent and low-cost labour.

### Production, Imports and Exports

The production, imports, and exports of electronic goods for the last four (04) years are presented below:

(Values in ₹ crore)

	2021-22	2022-23	2023-24	2024-25
Production*	6,40,810	8,25,000	9,52,000	11,32,752
Imports**	5,49,713	6,20,752	7,27,664	8,35,504
Exports**	1,16,895	1,89,934	2,41,157	3,27,187

\* Source: Industry Association for FY2024-25

\*\* Source: Directorate General of Commercial Intelligence and Statistics (DGCI&S)

- CAGR for Production from FY21-22 to FY24-25: 20.91%
- CAGR for Imports from FY21-22 to FY24-25: 14.98%
- CAGR for Exports from FY21-22 to FY24-25: 40.93%
- As per DGCI&S data, the imports of electronic goods has increased from ₹ 7,27,664 crore in FY 2023-24 to ₹ 8,35,504 crore in FY 2024-25.
- As per the data provided by DGCI&S, the export of electronic goods has increased from ₹ 2,41,157 crore in FY 2023-24 to ₹ 3,27,187 crore in FY 2024-25. The government has taken several measures for the growth of the exports of electronics hardware sector. Special Economic Zones (SEZs) have been set up to enable hassle-free manufacturing and trading for export purposes and Electronic Hardware Technology Park (EHTP) units are the major contributors to exports.

Electronics manufacturing sector has several verticals in terms of its constituents. The production profile of the electronics sector for FY 2023-24 and FY 2024-25, based on the information provided by Industry Associations is as follows:

Product Segment	FY23-24		FY24-25	
	(USD Bn)	(INR Crore)	(USD Bn)	(INR Crore)
Mobile Phones	51	4,22,000	64	5,45,000
IT Hardware (Laptops, Tablets)	5	41,395	5.3	45,156
Consumer Electronics (TV, Audio, Accessories)	13	1,07,627	13.2	1,12,464
Strategic Electronics	5.5	45,534	6.1	51,546
Industrial Electronics	12.5	1,03,487	13.1	1,11,825
Wearables & Hearables	2.5	20,697	2.6	21,726
Auto Electronics	8	66,378	8.6	73,272
LED Lighting	3.5	28,976	3.9	33,100
Telecom Equipment	3.5	28,976	5.3	44,730
Electronic Components	10.5	86,929	11.0	93,933
Electronics Manufacturing	115	9,52,000	133	11,32,752

Source: Industry Associations

### 3.2.1 Mobile Phones

India has emerged as the 2nd largest manufacturer of mobile handsets in the world in terms of volume. There are over 300 units manufacturing cellular mobile phones and parts/ components thereof in the country. The production of mobile phones stood at INR 5.45 lakh crore (~USD 64 billion) in FY24-25 as per industry association reports. The export of mobile phones stands at approx. INR 2.05 lakh crore (~USD 24.1 Bn) for FY 2024-25.

#### **Phased Manufacturing Programme (PMP) for mobile phones and specified sub-assemblies/parts thereof:**

The Phased Manufacturing Programme (PMP) for mobile phones and specified sub-assemblies/parts thereof was notified by MeitY on 28.04.2017 to promote domestic value addition in this sector. As a result of the PMP and other initiatives by the Government, India has rapidly started attracting investments into this sector and significant manufacturing capacities have been set up in the country. The manufacturing of mobile phones has been steadily moving from Semi Knocked Down (SKD) to Completely Knocked Down (CKD) level, thereby increasing the domestic value addition. Now, almost the entire demand for cellular mobile handsets is being met through domestic manufacturing, reflecting the success of these initiatives.

### 3.2.2 Information & Communication Technology (ICT) Hardware

The first application of electronics was in the domain of communication and computing. With the emergence of integrated circuit, the world saw the advent of the digital computer era, and with the advent of microprocessor in the 1970's, the world saw an exponential growth of the Information and Communication Technology (ICT) industry. Its strategic importance is such that countries across the world have declared it as an essential commodity. With its pool of technical manpower and proven capability as a design center for most of the global hardware companies, the country is ready to become an end-to-end player and global leader in the ICT hardware design and manufacturing space.

India has a huge opportunity arising from both import substitution and export led manufacturing in the space of ICT hardware. In addition, ICT hardware holds the promise of high value addition in India, with the manufacturing of the Components (i.e., Sub-Assemblies of ICT Products), Product design and Semiconductor Design being done in the country.

Emerging domains of AI, ML, IoT are becoming the new driving forces behind the growth of ICT hardware segment. These domains require the design of specialized Semiconductors, Sensors and Servers for which India has the capability. Another emerging domain in ICT hardware is the Large-Scale Data Centres. India with its technical prowess, cheap labour, large pool of manpower, and English as the working language, has the opportunity to lead the world in all these domains.

### 3.2.3 Consumer Electronics

Consumer electronics refers to any device containing an electronic circuit board that is intended for everyday use by individuals for the purpose of entertainment, recreation or communication. This encompasses a massive category of electronic products which includes televisions, cameras, digital cameras, PDAs, calculators, VCRs, DVDs, clocks, audio devices, headphones, and various other home products. The key drivers of growth in consumer electronics market include increased awareness, easier access, changing lifestyle, higher disposable income and reduction in the per unit prices.

Television is an important device in the home consumer electronics and has been identified as one product for which India can become the global hub for manufacturing. As per FICCI, India's TV production stood at USD 4.24 billion in 2020-21 and is expected to reach USD 10.22 billion by 2025-26 with a CAGR of 20%.

Some of the initiatives taken by the government are imposing the Basic Customs Duty (BCD) on several consumer electronic goods to encourage companies to substitute imported goods with domestically manufactured goods; permitting 100% FDI in the consumer electronics manufacturing sector via the direct route and providing Capex subsidy under the Modified Special Incentive Package Scheme (M-SIPS), etc. Due to these efforts, foreign companies have been encouraged to set up manufacturing facilities for consumer electronics without a joint venture or other form of partnership with a domestic entity. In distributing consumer electronic goods to their end users, a local partner is both legally and practically required.

### 3.2.4 Strategic Electronics

The strategic electronics segment consists of Military Communication systems, Radars and Sonars, Network Centric systems, Electronic Warfare systems, Weapon systems, Satellite based Communication, Navigation and Surveillance systems, Navigational aids, Underwater electronic systems, Infra-Red (IR) based detection and ranging system, Disaster management system, Internal security systems, etc.

India has the second largest armed force in the world, and is considered the seventh largest aerospace and defence (A&D) market globally with a sizeable budget to cover the needs of the country's Army, Navy and Air Force. The large-scale modernization of the defence forces and the drive to manufacture local have become focus areas of the government. Emerging technologies are going to reshape modern day warfare, and will harness the power of electronics to do so. This will make the Indian strategic electronics sector, mainly comprising aerospace and defence, a vibrant industry over the next decade.

The next decade is likely to see exponential growth in combat systems as well as non-platform-based programmes, facilitating smart battalions. Therefore, there are opportunities for electronics manufacturing in India in both standalone systems (as part of platforms) as well as at a sub-system level. Key factors that will influence growth are:

- The modernization of weapon platforms
- The induction of state-of-art weapons by the armed forces
- The impact of indigenization and the Make in India programme

### 3.2.5 Industrial Electronics

Industrial electronics can be classified based on segments viz Power Electronics, DC/ AC converters, Material handling and Industrial Robots. The key application segments of the industrial electronics industry are process control equipment, test and measuring equipment, power electronics equipment, automation and analytical instruments. These technologies are gaining ground as modernization, automation and robotics play an important role in the modern industry. The industrial electronics sector is witnessing growth due to enhanced digitization and robotics applications in Industry 4.0.

Increasing focus on the use of renewable power sources across the globe, growing adoption of power electronics in the manufacturing of electric vehicles, and increasing use of power electronics in consumer electronics are the major factors driving the growth of the power electronics market. Power electronics space in India is dominated by unorganized regional players, which is expected to grow at higher rate due to huge demand and low penetration. Inverters and UPS are also becoming household items driving the growth of this segment. Some of the Indian players have set up global tie-ups over the last few years and have brought in newer technologies into the Indian industry. Solar Photovoltaic and allied equipment is another segment which is likely to grow at a sustained high growth rate.

Industrial electronics is an empirical barometer of overall growth in the contribution of the manufacturing sector in the economy. The spurt in investments due to the “Make in India” programme is bringing significant interest in engineering, electrical, automotive and electronics segments which are the driving force behind the growth of industrial electronics sector. In future, M2M (machine-to-machine and machine-to-man) communication modules driven by Industry 4.0 activities will determine the growth of the Industrial electronic segment.

### 3.2.6 Automotive Electronics

Automotive electronics are electrically operated systems integrated and mounted in several vehicle applications such as body electronics, safety systems, and infotainment. The automotive market demand is experiencing trends related to advanced mobility solutions, powertrain & vehicle system electrification, and advanced safety systems. Due to the increased implementation of these systems in vehicles, the penetration of automotive electronics has also increased, further creating the demand for automotive electronics products across the globe. The digitization of automotive systems by including connected technologies, in-vehicle communication, and ADAS & automated systems have created several opportunities for market growth. The growing integration & adoption of automotive electronics in modern vehicles to deliver enhanced safety & comfort to consumers is one of the major factors driving the automotive electronics industry growth. Several features offered by OEMs including Automated Emergency Braking (AEB) system, airbag system, and lane departure warning, etc. have significantly decreased road accidents worldwide. Automotive electronics along with the presence of broad computing technologies and connected features are enhancing automobile capabilities. Alcohol ignition interlock, accident data recorder system, and emergency call system are some of the features gaining attraction, which will further propel the growth. According to Allied Market Research, the global Auto electronics market is estimated to reach USD 382.16 billion by 2026, growing at a CAGR of 7.3 percent from 2019 to 2026.

Automotive Mission Plan 2016-26 targets India to be among the top three in the world for engineering, manufacturing and export of vehicles and auto components. The growing presence of global automobile Original Equipment Manufacturers (OEMs) in the Indian manufacturing landscape has significantly increased the localization of their components in the country. India has become the preferred designing and manufacturing base for most global auto OEMs for local sourcing and exports.

### 3.2.7 Electronic Components

The global market for electronic components is expected to grow. Following this global trend, the Indian electronic components market is also poised to grow significantly. Mobile Phones, Consumer Electronics and Industrial Electronics account for the major demand (82%) for electronic components in India.

Gol launched the Scheme for Promotion of Manufacturing of Electronic Components and Semiconductors (SPECS) (notified vide Gazette Notification No.CG-DL-E-01042020-218992 dated April 01, 2020). This scheme provides financial incentive of 25% on capital expenditure for the identified list of electronic goods that comprise downstream value chain of electronic products, i.e., electronic components, ATMP units, specialized sub-assemblies and capital goods for manufacture of aforesaid goods, e-waste recycling facility and R&D units for the manufacturing of semiconductors. Apart from SPECS, the other initiatives of the Government that boost the production of electronic components include rationalization of tariff structure, Phased Manufacturing Programme (PMP), and notification of electronics products under the Public Procurement (Preference to Make in India), Order 2017. Under the umbrella of “Make in India” program, BCD has been imposed on Printed Circuit Board (PCB) Assembly of Mobile handsets with the intention to strengthen the domestic EMS and components segment in India. Production Linked Incentive Scheme (PLI) for Large Scale Electronics Manufacturing is also supporting manufacturing of specified electronic components. The Indian government has imposed an anti-dumping duty (ADD) on bare printed circuit boards (PCBs) with fewer than six layers.

Further, the Government has also notified Electronics Component Manufacturing Scheme on 08<sup>th</sup> April 2025 to develop a robust electronics component manufacturing ecosystem in India. The scheme offers differentiated incentives viz. (a) turnover linked incentive (b) capex incentive (c) hybrid incentive [i.e. combination of both (a) and (b)]. A part of turnover linked incentive and capex incentive is also linked with employment. The tenure of the scheme is six (6) years with one (1) year of gestation period i.e. from FY2025-26 to FY2031-32. The scheme is designed to broaden and deepen the electronics manufacturing ecosystem covering components and sub-assemblies, which have cross-sectoral applications such as mobile phone, IT hardware, consumer, telecom, auto, medical, industrial, etc.

The Electronics Manufacturing Services (EMS) industry in India is growing rapidly and key global players as well as a number of domestic companies are operational in the country. A strong component manufacturing base is essential for a sustainable Electronics System Design and Manufacturing (ESDM) ecosystem in India. This segment needs very high efficiency of operations to stay profitable. Availability of components and an effective supply chain is vital for EMS companies for their growth.

India's electronics sector has experienced substantial growth in manufacturing and has achieved considerable scale in assembly, largely driven by strategic government initiatives. It is high time to develop an ecosystem focused on component manufacturing to further this growth and enhance global competitiveness. In this regard, the Government is planning initiatives to develop a component manufacturing ecosystem.

### 3.2.8 Medical Electronics

Indian medical devices market is among the top twenty in the world by market size, and fourth in Asia after Japan, China and South Korea. The Government has taken various regulatory steps to promote this sector and has created excellent opportunities for the domestic manufacturers, thereby reducing the dependence on imports. Medical devices industry in the country is dominated by multinationals that controls about 75-80 per cent of the Indian market. Further, more than 80 percent of domestic manufacturers are in the small-scale sector and have a turnover of less than ₹ 10 crore. Also, more than 6,000 types of medical devices are in use worldwide, but India manufactures just one-sixth of these medical devices.

## 3.3 Schemes and programs

### 3.3.1 Electronics Component Manufacturing Scheme (ECMS)

Electronics Component Manufacturing Scheme was notified on 08<sup>th</sup> April 2025 to develop a robust electronics component manufacturing ecosystem in India. The scheme offers differentiated incentives viz. (a) turnover linked incentive (b) capex incentive (c) hybrid incentive [i.e. combination of both (a) and (b)]. A part of turnover linked incentive and capex incentive is also linked with employment. The tenure of the scheme is six (6) years with one (1) year of gestation period i.e. from FY2025-26 to FY2031-32. The application window for Target Segments A, B, C & E has closed on 30.09.2025. For Target Segment D, the window will remain open till 30th April 2027. Till 30.09.2025, the scheme has received total 249 applications. The target segments covered under ECMS includes display module sub-assemblies, camera module sub-assemblies, optical transceivers module- SFP, passive components, electro-mechanicals, PCBs including multi-layer, HDI, MSAP, and flexible PCBs, Li-ion cells for digital applications, enclosures for mobile, IT hardware products, and related devices, and supply chain components and capital equipment.

Status of ECMS till December 2025 is as follows:

As of 31 December 2025, a total of 24 applications has been approved across 9 states, with a projected investment of INR 12,704 crore, production of INR 109,517 crore, and generation of 17,003 direct employment.

### 3.3.2 Modified Special Incentive Package Scheme (M-SIPS)

In order to promote large scale manufacturing in the country, a Modified Special Incentive Package Scheme (M-SIPS) was announced by the Government in July 2012. The Scheme has been amended twice – in August 2015 and in January 2017. The Scheme has been closed on 31<sup>st</sup> December 2018 to receive new applications. The salient features of the Scheme are:

- Provides Capital Subsidy - 20% for investments in Special Economic Zones (SEZs) and 25% in non-SEZs.
- Provides incentives for both new units and expansion units.
- Provides incentives for a period of 5 years from the date of approval of application.
- Provides incentives for 44 categories/verticals across the value chain (raw materials including assembly, testing, packaging and accessories, chips, components).
- Minimum investment threshold for each product category/vertical Unit to be in Industrial Area notified by Central/ State Govt.

#### Status of M-SIPS till December, 2025 is as follows:

As on 31 December 2025, 304 applications with proposed investment of Rs 64,872 Crore are approved.

The incentives to the tune of Rs 2817.20 Crore have been disbursed to the 153 applicants.

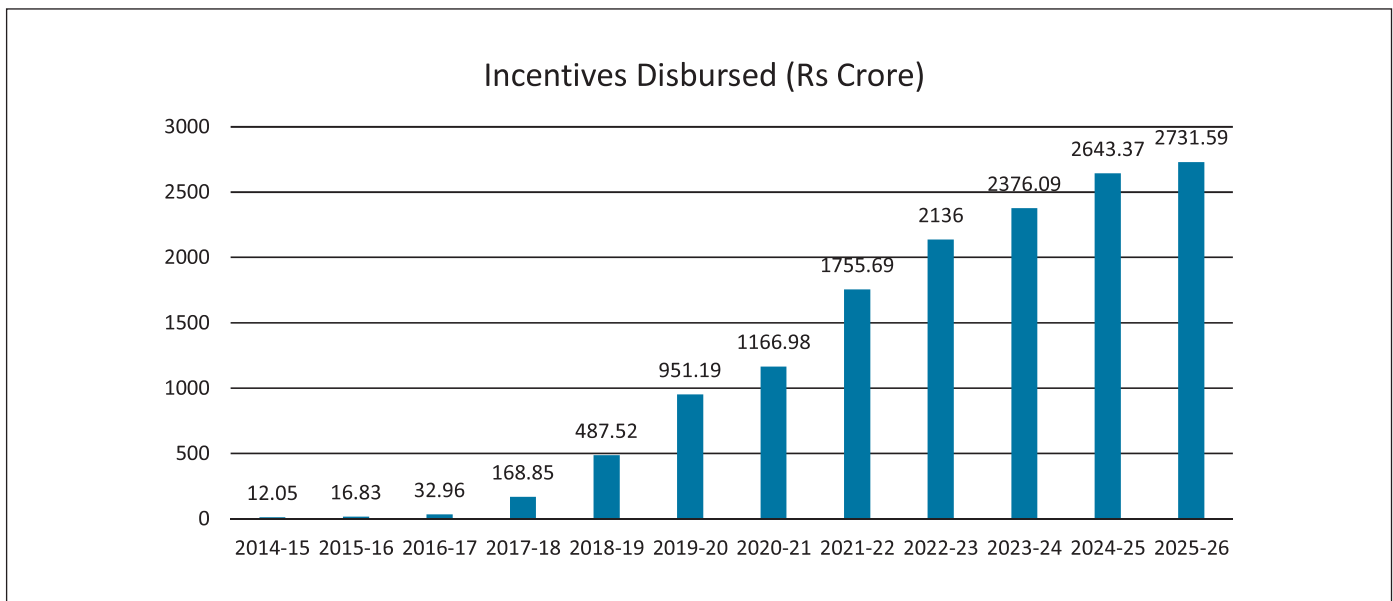

Out of 304 approved applicants, 288 applicants have started incurring investment on their projects and have made investment of Rs 54,117 Crore. Out of 304 approved applicants, 272 applicants have commenced commercial production with reported turnover of Rs 16,98,109 Crore, which includes exports to the tune of Rs 4,41,784 Crore. These units have given employment opportunities (Direct & Indirect) to over 4,79,548 persons and given revenue of approximately Rs 2,19,654 Crore to the Government.

### 3.3.3 Electronic Cluster Manufacturing (EMC) Schemes

To create conducive and sustainable ecosystem for electronics manufacturing in the country, Government notified the Electronics Manufacturing Cluster (EMC) Scheme in October, 2012 for providing support to create world-class

infrastructure along with common facilities and amenities for attracting investments in the ESDM sector. The scheme was open to receive applications for a period of five years from the date of its notification i.e., upto October, 2017. Further period upto March 2026 is available for disbursement of funds to the approved projects. The salient features of the scheme are as follows:

- i. To create robust infrastructure base for electronics manufacturing in the country through development of Greenfield EMCs and Common Facility Centres (CFCs).
- ii. Financial assistance upto 50% of the project cost subject to a ceiling of ₹ 50 crore for every 100 acres of land for Greenfield EMC and 75% of the cost of infrastructure, subject to a ceiling of ₹ 50 crore for Common Facility Centre.
- iii. State Government incentives are over and above the Central financial assistance.
- iv. Development of EMCs to provide ready infrastructure for industry engaged in electronics verticals and its entire value chain to set up their manufacturing facilities in EMC.

**Status of EMC till December, 2025 is as follows:**

Under the scheme, MeitY received 50 applications out of which 46 applications were for setting up of Greenfield EMCs and 4 applications for setting up of Common Facility Centers (CFC) in Brownfield Clusters from 19 states across the country. Of these, nineteen (19) Greenfield EMCs and Three (3) CFCs were accorded approval admeasuring an area of 3,464 acres with project cost of ₹ 3,499 crore including Grant-in-aid of ₹ 1,470 crore from Government of India. These EMCs were poised to attract an investment of ₹ 46,619 crore and are expected to generate 6.30 lakh employment opportunities once operational.

As on December, 2025, a Grant-in-aid amounting to ₹ 858.68crore has been released for implementation of these projects. These EMCs/CFCs are providing developed infrastructure with plug & play facility along with requisite testing/ validation services to electronics industry to start their production activity in the country. About 432 companies with projected investment of ₹ 55,347 crore have committed for setting up of their manufacturing facilities within these EMCs with estimated employment generation of about 2.78 Lakh. Of these, 161 companies started their commercial production with an investment of ₹ 19,973 crores and provided employment opportunities to over 77,179 persons. More than 1.5 crore man-days has been generated through these EMCs. In addition, 116 electronics manufacturing units are at various stages of construction and implementation.

### 3.3.4 Modified Electronics Manufacturing Clusters (EMC 2.0) Scheme

To provide avenues for expanding and strengthening of electronics manufacturing ecosystem in the country; Ministry of Electronics and IT notified the Modified Electronics Manufacturing Clusters (EMC 2.0) Scheme on April 01, 2020. By providing support for creation of world class infrastructure along with common facilities and amenities for attracting major global electronics manufacturers along with their supply chains, the scheme aims to make India an Electronics Manufacturing Hub. The scheme also provides requisite financial assistance for creation of industry specific facilities like Common Facility Centers, Ready Built Factory Sheds / Plug and Play facilities etc. This will attract large scale electronics manufacturers to commence their production in the country and act as Anchor units to bring their suppliers in such clusters. It will also ensure greater integration with the global supply chains in the electronics manufacturing sector. The salient features of EMC 2.0 Scheme are as follows:

- i) Financial assistance upto 50% of the project cost subject to ceiling of ₹ 70 crore per 100 acres of land for setting up of Electronics Manufacturing Cluster projects and 75% of the project cost subject to a ceiling of ₹ 75 crore for Common Facility Centres (CFCs).

- ii) Minimum land area requirement is 200 acres (100 acres in case of North-Eastern States, Hill States and UTs)
- iii) Commitment from Anchor Units for having min. 20% of saleable/ leasable area with investment Commitment of ₹ 300 crore (10% and ₹ 150 crore in case of North-Eastern States, Hill States and UTs)
- iv) Development of Ready Built Factory (RBF) Sheds and Plug & Play facilities in at least 10% of the saleable / leasable land area.
- v) Open for new as well as expansion of existing EMCs/CFCs.
- vi) Implementation and execution of scheme through Project Management Agency i.e., STPI.
- vii) State Government/its agencies, Central PSUs/State PSUs, Industrial Corridor Development Corporations (ICDCs) or joint venture of such agencies with Anchor units or industrial park developers (existing SPVs in case of expansion of projects) all eligible to apply
- viii) Scheme is open for receipt of application for a period upto March, 2024 and period upto March, 2028 is available for release of financial assistance to approved projects.

#### **Status of EMC 2.0 till December, 2025, is as follows:**

Under the Scheme, 11 applications for setting up of EMC and 2 applications for setting up of CFC admeasuring an area of 4,399 acres with a project cost of ₹ 5,226.49 crore including Central financial assistance of ₹ 2,492.75 crore have been approved. These EMCs are poised to attract an investment of ₹ 1,46,846 crore and have potential to generate about 1.80 lakh employment opportunities once fully operational. Financial assistance of ₹ 450.77crore has been released for implementation of these projects so far. An investment commitment of ₹ 1,24,124 crore has already been received from 123 companies with employment potential of 77,385 persons in these EMCs. 9 units have already started production and other 9 units are in construction. An investment of ₹ 10,908 crores has been mobilized with employment generation of 13,680 persons.

#### **3.3.5 Electronics Development Fund (EDF)**

Electronics System Design & Manufacturing is a sector which is characterized by high velocity of technological change. Intellectual Property is possibly the most critical determinant of success, not only for the companies of this sector but also to the countries and economies as a whole. Setting up of EDF was one of the important strategies to enable creation of an electronics industry ecosystem in the country. Encouraging a vibrant ecosystem of innovation, R&D with active industry involvement is essential for a thriving electronics industry. It is with this objective that an EDF has been set up as a “Fund of Funds” to participate in professionally managed “Daughter Funds” which in turn provides risk capital to companies developing new technologies in the area of Electronics and Information Technology (IT). This fund is expected to foster R&D and innovation in these technology sectors through creation of an ecosystem for providing risk capital to industry to undertake market driven R&D. It will, in the process, enrich the intellectual property in the country and encourage more entrepreneurs towards product and technology development.

Canbank Venture Capital Funds Ltd. (CVCFL), a 100% subsidiary of Canara Bank, is the Investment Manager and MeitY is the anchor investor of EDF. EDF has drawn ₹ 216.33 crore from its contributors, which includes ₹ 210.33 crore from MeitY. As on 30.11.2025; EDF has invested ₹ 257.77 crore in eight Daughter Funds, which in turn have made total investments of ₹ 1,335.77 crore in 128 Ventures/Startups. Total Funds raised by the supported startups of the Daughter Funds of EDF are approx. ₹ 21,913 crore (other than Daughter fund). Total employment in supported Startups was more than 22800 Number of IPs created/ acquired by the supported start-ups is 368. The supported start-ups and companies are majorly working in IOT, Robotics, Drones, Autonomous Cars, Health-tech, Cyber security, Artificial Intelligence / Machine Learning etc.

S. No.	Name of Daughter Fund	Amount invested by EDF (₹ crore)	Total No. of Investee entities of the DF	Amount of investments of the DF in these investee entities in (₹ crore)
1	Unicorn India Ventures Trust	15.82	17	63.64
2	Aaruha Technology Fund - 1	6.75	13	26.22
3	Endiya Seed Co-creation Fund	30.00	12	137.03
4	Karsemven_Fund	24.00	17	83
5	pi Ventures Fund 1	15.00	15	186.53
6	YourNest India VC Fund II	43.15	19	185.54
7	Ventureast Proactive Fund - II	97.75	18	425.70
8	Exfinity Technology Fund Series II	25.30	17	227.68
	<b>Total</b>	<b>257.77</b>	<b>128</b>	<b>1335.77</b>

### 3.3.6 Production Linked Incentive Scheme (PLI) for Large Scale Electronics Manufacturing

Production Linked Incentive Scheme (PLI) for Large Scale Electronics Manufacturing was notified vide Gazette Notification No.CG-DL-E-01042020-218990 dated April 01, 2020, to provide financial incentive to boost domestic electronics manufacturing and attract large investments. The Scheme extends an incentive of 4% to 6% to eligible companies on incremental sales (over base year i.e., 2019-20) of manufactured goods including mobile phones and specified electronic components for a period of five years subsequent to the base year.

Over the scheme tenure, the Scheme is expected to lead to total production of about ₹ 8.12 lakh crore. Out of the total production, about 60% is expected to be contributed by exports of the order of ₹ 4.87 lakh crore. The Scheme targets to bring additional investment in electronics manufacturing to the tune of ₹ 7,000 crore. PLI Scheme will also help in promotion of domestic champion companies by reviving Indian Brands and strengthening Indian EMS companies.

After the success of the First Round of Production Linked Incentive Scheme in attracting investments in mobile phone and electronic component manufacturing, Second Round of the PLI Scheme for Large Scale Electronics Manufacturing was launched on 11.03.2021 for incentivizing Electronic Components. Under the Second Round, incentives of 5% to 3% have been extended on incremental sales (over base year i.e., 2019-20) of goods manufactured in India and covered under the target segment, to eligible companies, for a period of four years.

In accordance with the announcement made by Hon'ble Union Finance & Corporate Affairs Minister on 28.06.2021 to provide relief to companies approved under the PLI Scheme affected by the COVID-19 pandemic, the tenure of the PLI Scheme has been extended by one year i.e., from 2024-25 to 2025-26. The notification in this regard was issued on 23.09.2021.

#### The status of PLI Scheme for LSEM till December 2025 is as follows:

As of December 2025, the companies approved under the PLI Scheme for LSEM have generated cumulative investment of INR 15,172 Cr, cumulative production of INR 10,22,687 Cr, cumulative exports of INR 5,67,442 Cr and cumulative employment of 1,47,572 (Direct jobs).

### 3.3.7 PLI Scheme 2.0 for IT Hardware

PLI Scheme 2.0 for IT Hardware was notified on 29.05.2023 with an approved outlay of Rs.17,000 crore to boost domestic manufacturing and attract large investments in the value chain. The Scheme extends an incentive of around 5% (based on localization of components/sub-assemblies) on net incremental sales (over base year) of goods manufactured in India and covered under the target segment, to eligible companies, for a period of six (6) years. The Target Segment includes (i) Laptops (ii) Tablets (iii) All-in-One PCs and (iv) Servers (v) USFF (Ultra Small Form Factor). A total of 27 companies have been approved under the Scheme.

**The Scheme is expected to generate following outcomes during its tenure:**

- i) Expected incremental production is Rs. 3.35 Lakh crore
- ii) Expected incremental investment is Rs. 2,430 crores
- iii) Expected incremental direct employment is 75,000

The status of PLI Scheme 2.0 for IT Hardware till December, 2025 is as follows:

As on 31.12.2025, PLI Schemes for IT Hardware have led to a total cumulative production of Rs. 16,531.64 crore, total cumulative investment of Rs. 856.64 crore and total cumulative employment of 4,776 (direct jobs).

### 3.3.8 Scheme for Promotion of Manufacturing of Electronic Components and Semiconductors (SPECS)

Notified vide Gazette Notification dated April 01, 2020, the Scheme provides financial incentive of 25% on capital expenditure for the identified list of electronic goods that comprise downstream value chain of electronic products, i.e., electronic components, semiconductor/ display fabrication units, ATMP units, specialized sub-assemblies and capital goods for manufacture of aforesaid goods, e-waste recycling facility and R&D units for the manufacturing of semiconductors. The scheme promotes development of electronic components manufacturing ecosystem in the country and deepening of electronics value chain and is expected to bring new investments to the tune of ₹ 20,000 crore with total employment generation potential of 6,00,000 (Direct and Indirect). The scheme is closed to receive new applications on 31.03.2024.

#### Progress under the scheme till December, 2025 as per latest Quarterly Progress Report

58 applications have been approved with total proposed investment of Rs. 22,081 crore. As per the Quarterly Progress report submitted by the applicant total investment done by the approved applications is Rs. 20,488 crore. Total production done by the approved applications is Rs. 49,352 crore. Total employment generated by the approved applications is 56,314 persons.

### 3.3.9 Programme for Development of Semiconductors and Display Manufacturing Ecosystem in India

Government of India approved the comprehensive program for the development of a sustainable semiconductor and display ecosystem in the country with an outlay of ₹ 76,000 crore (>10 billion USD) in order to foster the objective of the development of a diversified, resilient, and sustainable semiconductor and display manufacturing ecosystem in India, which provides

- i. Fiscal support of 50% of the project cost on *pari-passu* basis for setting up of Silicon Complementary Metal-Oxide-Semiconductor (CMOS) based Semiconductor Fabs in India.
- ii. Fiscal support of 50% of Project Cost on *pari-passu* basis for setting up of Display Fabs in India.
- iii. Fiscal support of 50% of the Capital Expenditure on *pari-passu* basis for setting up of Compound Semiconductors / Silicon Photonics (SiPh) / Sensors (including Micro-Electro-Mechanical Systems) Fab/ Discrete Semiconductor

Fab and Semiconductor Assembly, Testing, Marking and Packaging (ATMP) / Outsourced Semiconductor Assembly and Test (OSAT) facilities in India.

- iv. Product Design Linked Incentive (DLI) of up to 50% of the eligible expenditure subject to a ceiling of ₹15 Crore per application and also “Deployment Linked Incentive” of 6% to 4% of net sales turnover over 5 years subject to a ceiling of ₹30 Crore per application for incentivizing chip design

Government has also approved the modernization of Semi-Conductor Laboratory, Mohali under the Programme.

### 3.3.9.1 India Semiconductor Mission (ISM):

India Semiconductor Mission (ISM) as an Independent Business Division under the Digital India Corporation, has been nurturing India’s strategies for developing Semiconductors and display ecosystem focussed on the objectives namely-

- Promoting development of indigenous products/ technologies via suitable mechanisms/ infrastructure facilities
- Enabling cutting-edge research and development and curating pool of skilled manpower.
- Encouraging technology transfer by networking/ partnerships with national and international entities.
- Assisting in obtaining monetary support through requisite fund mechanisms/ grants schemes, etc.
- Facilitating adoption of secure microelectronics and developing a trusted semiconductor supply chain.

### 3.3.9.2 Modernization of Semi-Conductor Laboratory (SCL), Mohali

The Union Cabinet has also approved that Ministry of Electronics and Information Technology will take requisite steps for modernization and commercialization of Semi-conductor Laboratory (SCL), Mohali. Semi-conductor Laboratory (SCL), Mohali has been brought under the administrative control of Ministry of Electronics and Information Technology from Department of Space

SCL is an Integrated Device Manufacturer which undertakes activities pertaining to design, development, fabrication, assembly & packaging, testing and quality assurance of Silicon CMOS and MEMS Devices for various applications. Presently, SCL has two wafer fabrication lines, i.e., 200 mm wafer line operating in 180nm CMOS technology and 150 mm wafer line for MEMS technology. SCL predominantly caters to low volume requirements for various applications.

Boston Consulting Group (BCG) has been engaged to provide consultancy services for the Modernization of Semi-Conductor Laboratory, Mohali.

The primary focus of the modernization of SCL is the 8-inch 180nm CMOS fab-line with the following outlined objectives:

- (i) Augment the capacity of the line to at least 1500 WSPM, build redundancy and improve operational performance
- (ii) Enhance technological capability to support broader needs of government, academia and industry
- (iii) Ensure operational continuity and improved customer commitment.

As part of its modernization, SCL published RFP and invited proposals to upgrade its chip manufacturing facilities. Through this RFP, SCL intends to engage experienced Contractor(s) for augmentation and enhancement of the existing 8-inch fab-line. The technical evaluation and financial evaluations of the bids received have been completed, and the results have been published on the SCL website.

### 3.3.9.3 Approvals issued under the programme:

- Micron Technology Inc.’s proposal for setting up an ATMP facility in Gujarat with an investment of ₹ 22,516 crore was approved in June 2023. Micron’s facility in India will enable assembly and test manufacturing for both DRAM and NAND products and address demand from domestic and international markets. The production capacity is around 14 million units per week.

- Tata Electronics Private Limited (TEPL)'s proposal for setting up a Semiconductor Fab facility in Gujarat with an investment of ₹ 91,526 crore was approved in February 2024. The fab facility will be set up in technology partnership with PSMC, Taiwan. PSMC is an established semiconductor company having 6 semiconductor foundries in Taiwan. The production capacity of the project would be around 50,000 wafer starts per month (WSPM).
- Tata Electronics Private Limited (TEPL)'s proposal for setting up of OSAT facility in Assam with an investment of ₹ 27,120 crores was approved in February 2024. The facility will use indigenous semiconductor packaging technologies with a production capacity of 48 million per day.
- CG Power and Industrial Solutions Limited's proposal for setting up OSAT facility in Gujarat with an investment of ₹ 7,584 crore was also approved in February 2024. The facility will be set up as joint venture partnership with Renesas Electronics America Inc., USA, and STARS Microelectronic, Thailand. The Technology would be provided for this facility by Renesas Electronics Corporation, Japan and STARS Microelectronic, Thailand. The production capacity would be around 15.07 Million Units per day.
- Kaynes Technology India Limited (KTIL) proposal for setting up of Outsourced Semiconductor Assembly and Test (OSAT) facility in Gujarat for Wire bond Interconnect, Substrate Based Packages was approved in September, 2024. The Technology would be provided by ISO Technology Sdn. Bhd. and AOI Electronics Co. Ltd. (AOI). This facility will be setup with an investment of ₹ 3,307 crore. The facility will have the capacity to produce more than 6.33 million chips per day.
- Vama Sundari Investments (Delhi) Private Limited (VSIPL) proposal for setting up of Outsourced Semiconductor Assembly and Test (OSAT) facility in Uttar Pradesh for display driver ICs (DDIC) using Gold (Au) Bump technology along with chip probing facilities and die processing services was approved in May, 2025. The Technology would be provided by Hon Hai, Taiwan. The facility will be set up as joint venture partnership between VSIPL and Foxconn, India with an investment of Rs 3,706 crore. The production capacity would be around 20K wafers per month/36 Mn chips per month.
- 3D Glass Solutions Inc. (3DGS) proposal for setting up of a vertically integrated advanced packaging and embedded glass substrate manufacturing on the glass panels in Odisha with an investment of ₹ 1,943 crores has been approved in August, 2025. The plant will handle the assembly of packaged products such as Flip Chip Ball Grid Array (FCBGA) assembly, Radio Frequency System in Package (RF SiP), Antenna in Package System in Package (AiP SiP), glass interposers with passives and silicon bridges and 3D Heterogenous Integration (3DHI) modules. Proposed Installed capacity for glass panel substrate production, assembly and 3DHI is around 5800 panels per month, 4.20 million units per month, and 1100 units per months respectively.
- SiCSem Private Limited's proposal for setting up an integrated facility for Silicon Carbide (SiC) based Compound Semiconductors fab and ATMP in Odisha with an investment of ₹ 2,066 crore has been approved in August 2025. The facility will be set up in technology partnership with Clas-SiC Wafer Fab Ltd. for SiC fab and Continental Device India Pvt. Ltd. for packaging. The production capacity is 5,000 wafers/month and packaging capacity of 8 million units/month.
- Continental Device India Private Limited (CDIL) proposal for Brownfield expansion of its semiconductor manufacturing facility at Punjab, with an investment of ₹ 117 crores has been approved in August 2025. The proposed facility will manufacture high-power discrete semiconductor devices such as MOSFETs, IGBTs, Schottky Bypass Diodes, and transistors, both in Silicon and Silicon Carbide. The production capacity of the will be around 158.38 million units/annum.
- Advanced System in Package Technologies Private Limited (ASIP) proposal for setting up an OSAT facility in Andhra Pradesh, with an investment of ₹ 480 crores in August 2025. The facility will be set up in technology partnership with APACT Co. Ltd, South Korea. The production capacity of the facility would be around 96 million units/annum.

- 100 start-ups and MSMEs companies have been approved for design infrastructure support under the DLI Scheme made available by ChipIN Centre at C-DAC Bengaluru. Out of these, 24 applications have also been approved for financial support for developing semiconductor chip/ SoCs for applications in sectors such as automotive, mobility, computing, communications etc namely - DV2JS Innovation LLP, Vervesemi Microelectronics, Fermionic Design, Morphing Machines, Calligo Technologies, Sensesemi Technologies, Saankhya Labs, Aryabhata Circuits and Research Labs, BigEndian Semiconductors, C2i Semiconductors, Aheesa Digital Innovations, Mindgrove Technologies, InCore Semiconductors, Netrasemi, Green PMU Semi, WiSig Networks, MosChip Technologies, Mblt Wireless, Multi Nano Sense Technologies Pvt. Ltd., Sophrosyne Technologies Pvt. Ltd. MMRFIC Technology Pvt. Ltd. and Incise Infotech Limited.

#### 3.3.9.4 International Collaborations in the field of Semiconductors:

Becoming a self-sufficient chip manufacturing nation is a complex and multifaceted endeavour that depends on various factors, including technological advancements, research and development (R&D), skilled labour, investment, infrastructure development, policy support, and global market dynamics. Recognising the internationally integrated nature of Semiconductor Industry, Government of India started engaging with other countries to establish a resilient Semiconductor Supply Chain and Innovation Partnership.

- **MoU with USA:** Government of India had signed MoU with USA for establishing semiconductor supply chain and innovation partnership under the framework of India-United States Commercial Dialogue to enhance bilateral collaboration on opportunities to advance resilient semiconductor supply chains and leverage complementary strengths.
- **MoC with Japan:** Government of India has also signed a Memorandum of Cooperation (MoC) with Government of Japan for “Semiconductor Supply Chain Partnership” to strengthen cooperation between Japan and India towards the enhancement of semiconductor supply chain.
- **MoU with European Union:** Government of India has signed an MoU with EU, to deepen cooperation on semiconductor ecosystem, its supply chains and innovation and leverage complementary strengths by exchanging best practices w.th regard to their respective semiconductor strategies and programs.
- **MoU with Singapore:** Government of India has signed an MoU with Singapore to establish the “India-Singapore Semiconductor Ecosystem Policy Dialogue,” aimed at enhancing cooperation in semiconductor supply chains, R&D, business partnerships, and workforce development, while promoting joint initiatives to boost resilience and growth in the semiconductor industry.
- **MoU with Netherlands:** A Memorandum of Understanding between Ministry of Electronics & Information Technology, Government of the Republic of India and Ministry of Economic Affairs of the Netherlands and the Ministry of Foreign Affairs of the Kingdom of the Netherlands on the India-Netherlands Partnership on Semiconductors and Related Emerging Technologies was signed in May 2025.

#### 3.3.9.5 Capacity building and talent development for semiconductors:

- Recognizing the importance of Talent development in Semiconductor domain, Government of India has been making significant efforts to develop talent in the semiconductor domain. AICTE launched following model curriculum for UG, Diploma, Minor Degree in Semiconductor domain as a step towards creation of Talent pool in Semiconductor domain:
  - B. Tech in Electronics Engineering (VLSI Design and Technology)
  - Diploma in IC manufacturing
  - Minor Degree in Electronics Engineering (VLSI Design and Technology)

These courses will help in creating Semicon industry ready talent pipeline and will reduce the time gap to make students industry ready.

- India is also collaborating with countries overseas for capacity building and Talent development in Semiconductor domain. ISM has signed an MoU with Purdue University, to enable collaboration for development of skilled workforce (through curation of specific courses/ academic programs), specialized R&D programs.
- Lam Research, USA, Semiconductor Equipment Manufacture announced to train 60,000 workforce in the next 10 years through its Semiverse Solutions virtual nano-fabrication platform and course customization in collaboration with IISc and Indian academic institutions, aiming to expedite India's semiconductor education and workforce development goals. After a successful completion of pilot programme, an MoU has been signed between ISM, IISc Bangalore and LAM Research in April 2024, to scale up the training. Under the MoU, a project is being implemented to train up to 4800 students in two years.
- NIELIT has jointly finalized the course curriculum with Tata Electronics Pvt. Ltd. for skilling manpower in various verticals of Semiconductor Assembly, Testing, Marking and Packaging. NIELIT is planning to roll out these skilling programs in its following Centers: Tezpur / Guwahati, Imphal, Agartala, Aurangabad, and Calicut.
- The First India-Dutch Semicon School has been conducted over five days, from 9-13th December, 2024 in online mode. The program featured 2 or 3 lectures each day, along with a group assignment at the end of the program. 170 students participated in the program from the following institutions: IIT Delhi, IIT Madras, IIT Guwahati, IIT Gandhinagar, Technical University Eindhoven, University of Twente, Technical University Delft.
- Proposal on "Upskilling program for Master Trainers in Japan" for training of 50 Indian master trainers in Japan was approved at the 158<sup>th</sup> meeting of the Screening Committee held on 29.08.2025. Under this program, 50 master trainers will be upskilled in Japan through hands-on training (Technician and Engineer level) at shop floor in areas such as Facility management, Fab Operations, Maintenance Engineer, Semiconductor Packaging and Testing, Reliability and Failure Analysis. The implementation schedule for the training program of 50 master trainers is tentatively planned from May 2026 to March 2028.

### 3.3.9.6 Outreach Activities:

#### Semicon India Conference 2025:

'SEMICON India 2025' Conference has been organized from 2<sup>nd</sup> –4<sup>th</sup> September, 2025 with the Theme 'Building the Next Semiconductor Powerhouse'. The event witnessed the super success with over 30,000 attendees, participation from 48 countries, and more than 350 companies showcasing innovations. Unique features included country pavilions, workforce development sessions, and student mentoring programs.





#### The key announcements that were made during the event are:

- Reopening of the EDA tool access window under the Design Linked Incentive (DLI) scheme.
- Selection of 30 semi-finalists under the Digital India RISC-V Grand Challenge.
- GlobalFoundries' support for DLI-approved companies through the India Foundry Connect program.
- Collaboration between ChipIN Center and Odisha's O-Chip program to boost fabless design in the state.
- Moschip Technologies unveiled the roadmap for the indigenous VIDYUT chip for smart energy meters.
- NetraSemi and PRAMA India announced a partnership to integrate indigenous chips into CCTV surveillance devices.
- C-DAC signed MOUs with international partners to advance cryogenic chip design and hybrid quantum computing capabilities.

#### 3.3.9.7 Employment

The semiconductor manufacturing facilities will generate direct employment of more than 25 thousand advanced technology jobs and about 60 thousand indirect jobs.

#### 3.3.9.8 R&D Road map

- **Applied Materials Inc. (AMAT)** has announced a planned investment of \$400 Mn to establish Collaborative Engineering Centre in Bangalore. During the initial 5 years, the center would support \$2Bn+ of spending and create ~500 advanced engineering jobs. This initiative will facilitate R&D collaboration amongst R&D team of Applied Materials, Indian academic institutions and R&D team of vendors of Applied Materials. This will also help in development and sourcing of components/sub-assemblies required for the AMAT's semiconductor equipment.
- **Advanced Micro Devices:** Advanced Micro Device (AMD) announced plan to invest approximately \$400 Million over the next five years to expand Research, Development and Engineering Operations in India. The planned investment includes a new AMD campus in Bangalore, Karnataka that will serve as the company's largest design center, as well as the addition of approximately 3,000 new engineering roles by the end of 2028. AMD committed to an investment of \$73Mn for Year 2024 and \$32Mn for Year 2025 as a part of \$400Mn investment. It has hired 980 Engineers, including 22% women.
- **Microchip:** Microchip Technology announced a \$300 million investment plan to expand its operations in India. To strengthen its presence in India, the company has inaugurated a new research and development (R&D) facility at One Golden Mile Office Tower in Hyderabad. This 168,000-square-foot center, which has a capacity for 1,000 employees, joins Microchip's existing developments in Bengaluru and Chennai. Microchip has added more than

200 engineers to the workforce. The Phase II office of Microchip is underway to add more than 1200 engineers in Chennai.

**MoU with Singapore:** Government of India has recently signed an MoU with Singapore to establish an “India-Singapore Semiconductor Ecosystem Policy Dialogue”. The Policy Dialogue will be used as a platform to:

- Discuss semiconductor supply chain related issues;
- Exchange best practices to leverage opportunities for growth in the global semiconductor industry;
- Explore areas for mutually beneficial semiconductor R&D collaboration;
- Encourage collaboration between Singapore-based and India-based companies towards mutually beneficial semiconductor related business opportunities and partnerships;
- Consider initiatives to enhance semiconductor supply chain resilience, based on areas of mutual strength such as fabs, packaging, design, equipment, specialty chemicals and gases, semiconductor grade materials; and
- Promote Industrial Parks and workforce development for mutual benefit

### 3.3.9.8 R&D Road map

- **Applied Materials Inc. (AMAT)** has announced a planned investment of \$400 Mn to establish Collaborative Engineering Centre in Bangalore. During the initial 5 years, the center would support \$2Bn+ of spending and create ~500 advanced engineering jobs. This initiative will facilitate R&D collaboration amongst R&D team of Applied Materials, Indian academic institutions and R&D team of vendors of Applied Materials. This will also help in development and sourcing of components/sub-assemblies required for the AMAT’s semiconductor equipment.
- **Advanced Micro Devices:** Advanced Micro Device (AMD) announced plan to invest approximately \$400 Million over the next five years to expand Research, Development and Engineering Operations in India. The planned investment includes a new AMD campus in Bangalore, Karnataka that will serve as the company’s largest design center, as well as the addition of approximately 3,000 new engineering roles by the end of 2028. AMD committed to an investment of \$73Mn for Year 2024 and \$32Mn for Year 2025 as a part of \$400Mn investment. It has hired 980 Engineers, including 22% women.
- **Microchip:** Microchip Technology announced a \$300 million investment plan to expand its operations in India. To strengthen its presence in India, the company has inaugurated a new research and development (R&D) facility at One Golden Mile Office Tower in Hyderabad. This 168,000-square-foot center, which has a capacity for 1,000 employees, joins Microchip’s existing developments in Bengaluru and Chennai. Microchip has added more than 200 engineers to the workforce. The Phase II office of Microchip is underway to add more than 1200 engineers in Chennai.

### 3.3.10 Investment Promotion to Attract Investment in ESDM Sector

#### 3.3.10.1 Promotion of ECMS, PLI, SPECS, EMC 2.0 and Schemes for Development of Semiconductors and Display Manufacturing Ecosystem in India

To boost investment in India’s Electronics System Design and Manufacturing (ESDM) sector, the Ministry undertook a series of targeted promotion initiatives, including the launch of a new initiative i.e. Electronics Component Manufacturing Scheme. Extensive outreach efforts - such as webinars, seminars, roadshows and stakeholder consultations - were conducted to highlight the benefits of these schemes. High-level engagements were also facilitated, enabling direct interactions between industry representatives and senior MeitY officials to address concerns and provide clarity on investment pathways. These efforts have positioned India as a promising destination for ESDM, significantly enhancing global awareness and industry interest.

### 3.3.10.2 Advocacy and Outreach Programmes

#### 3.3.10.2.1 Launch of ECMS Guidelines and Online Portal

On 26<sup>th</sup> April, 2025, MeitY organized a launch event for the Electronics Component Manufacturing Scheme (ECMS), which marked a major milestone for India’s electronics ecosystem. Hon’ble Minister of Electronics and IT, Ashwini Vaishnaw unveiled the scheme guidelines and online portal, with strong participation from government, industry, and global stakeholders. The event showcased the scheme’s innovative approach, commitment to Six Sigma standards and design excellence, and its focus on employment generation and supply chain integration. The occasion also saw Sarvam AI selected to build India’s first indigenous AI foundational model, reflecting India’s growing capabilities in electronics and AI. The launch draws attention to India’s robust strategy toward becoming a global electronics manufacturing hub.



#### 3.3.10.2.2 5<sup>th</sup> Electronics Supply Chain Summit

On 16<sup>th</sup> May 2025, ELCINA organized 5<sup>th</sup> Electronics Supply Chain Summit at the Radisson Hotel in Sector 18, Noida, Uttar Pradesh. Director, MeitY, discussed about the contours of newly notified Electronics Component Manufacturing Scheme (ECMS) during the Investors Roundtable. The discussion focused on promoting investment under the ECMS. The event brought together EMS manufacturers, component manufacturers, investors, industry associations, and state government representatives.



### 3.3.10.2.3 NAMTECH Roundtable on Talent & Capacity Building for Sustainable Manufacturing: Global Perspectives, local Action

On 22<sup>nd</sup> May 2025, NAMTECH organized a Roundtable on “Talent & Capacity Building for Sustainable Manufacturing: Global Perspectives, Local Action.” The event was graced by the Union Minister of Electronics & IT and brought together industry leaders, academia, and global partners, including MIT and Suzuki, to deliberate on skill development, innovation, and sustainable practices in manufacturing. The roundtable also facilitated strategic collaborations with partners such as GSV, Siemens, and Applied Materials for developing skilling frameworks and research infrastructure in smart manufacturing and emerging technologies. The initiative reinforced NAMTECH’s commitment to creating a future-ready workforce and advancing India’s vision of Viksit Bharat 2047.



### 3.3.10.2.4 Roadshows for promotion of Electronics Component Manufacturing Scheme (ECMS) in Andhra Pradesh, Pune, Gandhi Nagar and Orissa

In June 2025, to promote investment under the Electronics Component Manufacturing Scheme (ECMS) and to sensitize the industry, MeitY organized a series of roadshows at Tirupati (Andhra Pradesh), Pune (Maharashtra), Gandhinagar (Gujarat), and Bhubaneswar (Odisha). The roadshows were led by the Joint Secretary and Director, MeitY, in collaboration with leading industry associations.

These events witnessed participation from EMS manufacturers, component manufacturers, investors, industry associations, and state government representatives. The initiative generated strong interest and has resulted in significant traction for ECMS applications.

### 3.3.10.2.5 Seminar for promotion of Electronics Component Manufacturing Scheme (ECMS)

On 16<sup>th</sup> June 2025, MeitY, in partnership with the Consulate General of India in Guangzhou, organised a Seminar-cum-B2B Meet to showcase investment opportunities in India’s consumer electronics sector and promote the Electronics Component Manufacturing Scheme (ECMS). Director, MeitY, outlined the scheme’s investor-friendly framework, emphasizing its ease of implementation, global competitiveness, and long-term policy stability. The session generated strong interest from global companies and their supply chain partners operating in China.

On 17<sup>th</sup> June, 2025, MeitY, in collaboration with the Embassy of India in Tokyo, organised an India–Japan Seminar to promote participation in the Electronics Component Manufacturing Scheme (ECMS). Secretary, MeitY, highlighted the strong India–Japan synergy in the electronics value chain and invited Japanese companies to partner in advancing value addition through ECMS beyond PLI-led assembly growth. Director, MeitY, outlined the scheme’s industry-friendly features and global competitiveness, positioning ECMS as a compelling opportunity for manufacturing investments under the Make in India vision. The seminar received positive response from Japanese industry.

### 3.3.10.2.6 AI Infrastructure for Bharat

On 20<sup>th</sup> June 2025, Joint Secretary Shri Sushil Pal addressed the AI Infrastructure for Bharat event hosted by Netweb and NVIDIA. He outlined MeitY's efforts to position India as a global hub for IT hardware manufacturing, noting that the success achieved in mobile manufacturing is now paving the way for a similar transformation in the IT hardware sector. With strengthening domestic capabilities and supportive policy interventions, India is set for rapid growth in innovation-led manufacturing, contributing to both economic expansion and technological self-reliance.

### 3.3.10.2.7 Investment Promotion Roadshow for Electronics Component Manufacturing Scheme (ECMS), Taiwan

From 9–11 July 2025, a delegation from the Ministry of Electronics and Information Technology (MeitY), led by Shri Sushil Pal, Joint Secretary, visited Taiwan to promote investment in India's electronics manufacturing sector. The visit included an Investment Promotion Roadshow, the India–Taiwan Electronics Supply Chain Roundtable (attended by over 60 Taiwanese companies), and focused one-to-one meetings with leading firms such as Advantech, Foxconn, Unimicron, Supermicro, Compal, MSI, and others. The delegation highlighted India's growth in electronics manufacturing, the Electronics Component Manufacturing Scheme (ECMS), and Production Linked Incentive (PLI) schemes, while encouraging Taiwanese companies to expand their manufacturing footprint in India.



### 3.3.10.2.8 India–Japan Industrial Collaboration and Investment in Electronics Manufacturing, Japan

From 14–19 September 2025, a delegation led by Secretary, Department for Promotion of Industry and Internal Trade (DPIIT), visited Japan to advance the India–Japan Industrial Competitiveness Partnership.

Joint Secretary, participated in the delegation with a focus on promoting investment in India's electronics manufacturing sector and facilitating partnerships between Japanese companies and Indian industry.

During the visit, the Joint Secretary held one-on-one meetings with leading Japanese firms, including Air Water, FANUC, NIDEC, Sharp, and TDK. The delegation showcased India's growth in electronics manufacturing, highlighting the Electronics Component Manufacturing Scheme (ECMS) and Production Linked Incentive (PLI) schemes, while encouraging Japanese companies to expand their manufacturing footprint in India.

### 3.3.10.2.9 Measures to facilitate Ease of Doing Business

Central Board of Indirect Taxes & Customs (CBIC), Department of Revenue, Ministry of Finance has decided to exempt the Electronics and Semiconductor Manufacturing Sector from application of Section 65A of the Customs Act.

### 3.3.11 Other programs

#### 3.3.11.1 Compulsory Safety Standards for Electronics

The “Electronics and Information Technology Goods (Requirements for Compulsory Registration) Order, 2012” was notified on 3rd October, 2012 under the Compulsory Registration Scheme notified by Bureau of Indian Standards (BIS) under the ambit of the BIS Act, 1986, to ensure the safety of Indian consumers and curb the inflow of substandard electronic products. The Order has been migrated to BIS Act 2016 as “Electronics and Information Technology Goods (Requirement of Compulsory Registration) Order, 2021”. necessitates creation of an institutional mechanism for developing and mandating

standards and certification for electronic products to strengthen Conformity Assessment infrastructure nationwide. As per the provisions of the Order, before manufacturing, import, sale, stock etc of the products notified under the schedule of the Order, the products need to be registered with BIS based on testing of the notified product at BIS recognized laboratories as per the Indian Standards. The registration is granted to a manufacturer for manufacturing a product at a particular location. As on date, 65 products have been notified under the schedule of the Order. MeitY has also notified the Essential requirements (ERs) of security of CCTVs under the ambit of the order to protect sensitive information and to ensure proper functionality of CCTV systems.

The Compulsory Registration Scheme has resulted in high compliance of notified electronic goods to Indian safety standards and more than 50,000+ registrations have been granted by BIS to manufacturing units covering approximately 4,00,000 products models/series.

#### 3.3.11.2 Public Procurement (Preference to Make in India) Order 2017

Government has issued Public Procurement (Preference to Make in India) [PPP-MII] Order 2017 vide the Department for Promotion of Industry and Internal Trade (DPIIT) Order No. P-45021/2/2017-B.E.-II dated 15.06.2017 with subsequent revisions dated 28.05.2018, 29.05.2019, 04.06.2020, 16.09.2020 and 19.07.2024 to encourage ‘Make in India’ and to promote manufacturing and production of goods, services and works in India with a view to enhancing income and employment.

In furtherance of the aforesaid revised Order, MeitY has notified mechanism for calculating local content for 14 Electronic Products dated 07.09.2020 and 06.03.2024 viz., (i) Desktop PCs, (ii) Thin Clients, (iii) Computer Monitors, (iv) Laptop PCs, (v) Tablet PCs, (vi) Dot Matrix Printers, (vii) Contact and Contactless Smart Cards, (viii) LED Products, (ix) Biometric Access Control / Authentication Devices, (x) Biometric Finger Print Sensors, (xi) Biometric Iris Sensors, (xii) Servers, (xiii) Cellular Mobile Phones and (xiv) CCTV/VSS Systems, for procurement to be made from local suppliers.

### 3.3.12 Centre of Excellence in Electronics and ICT application

#### 3.3.12.1 National Centre of Excellence for Large Area Flexible Electronics (NCFlexE)

The project for setting up of National Centre of Excellence for Large Area Flexible Electronics (NCFlexE) at IIT-Kanpur was approved on 14<sup>th</sup> November, 2014 with a project cost of ₹ 132.99 crore including Government Grant-in-aid (GIA) of ₹ 111.12 crore. The main objective of the NCFlexE centre is to establish a research programme to engage in leading edge research in large area of flexible electronics and building strategic academic collaborations to address requirements through joint technology developments and to realize home grown technologies for manufacturing.

**OPV on Paper**      **OPV on Glass**      **Gas sensing prototype**      **Temperature sensing prototype for healthcare**      **Transpacks: An IIT Kanpur Start-up**

**PVDF based piezo sensors**      **IV level monitoring**      **Printed heaters for wearables**      **Warm Hug**

**Printed Components**      **Printable conductive inks**      **Education kit**

**Flexible OLEDs and TFT Circuits**      **OLED Displays and Signage**      **TFT based circuits and arrays**      **Tamper Evident RFID Tags**

**ISFETs for wearables and packaging**      **Brand protection label**

**ToT: Algorithm to categorize the quality of milk**

**Technology Readiness Level**

**Fundamental Research**      **Technology Development**      **Technology Demonstration**      **System Level Integration**      **Productisation**

**Product/prototype developed in the Centre**

The centre has been established with state-of-the-art laboratory facilities in the emerging flexible electronics area and has a portfolio of 64 filed patents. 7 Technology/ Know-how have been transferred to industry including incubation & mentoring support to start-ups. A startup M/s Transpack Ltd. has been incubated in Anti-counterfeiting technology.

The technology has been transferred to M/s SPMCIL and got ordered of more than ₹ 300 crore from Delhi Excise Department etc. The other startup M/s Likhtronics Pvt. Ltd. has been incubated recently for the product Educational Kits using special inks. In addition, 5 technologies of the centre have been transferred to industries/start-ups for commercialization. Several companies have invested in the centre for R&D, prototype & product developments etc. The Centre is working closely with industries to meet their requirement in this thematic area and developed various prototypes like Temperature Sensors for Milk Adulteration & Gas Sensors for Food Spoilage, Smart Label with tamper evident tracking, OLED Display, Handheld Infrared Thermometer, Screen-printed sensor for Bilirubin detection in Serum, Warm Hug/Heater Jackets, TFT Array, Sensor for Breast Cancer detection, Smart IV Bottle, Piano keyboard on paper etc.

Based on achieving of targeted objectives & milestones successfully and steer the centre activities ahead, the Ministry of Electronics & IT (MeitY) accorded approval to IIT-Kanpur on 24.11.2023 for initiation of Phase-II activity with a project cost of ₹ 83.08 crore including Government Grant-in-aid of ₹ 60.00 crore from MeitY, ₹ 10.00 crore as industry contribution and ₹13.08 crore from IIT-Kanpur. As on date, MeitY has released a Grant-in-aid of ₹10.79 crores to IIT-K towards the Phase-II of the project. Under the Phase-II, prima-facie, the prototypes /technological applications in the field of “Level & Packaging, Strategic and Healthcare sector (but not limited to)” has been considered to address the technological requirement of the industry/organization in these sectors. The center facility is available for industry / start-ups / academia / MSME /other organizations for active collaboration. Under Phase-II, 30 patents have been filed. The following 2 Technologies have been transferred to the industry.

Product /Technology	Industry	Sector	Status
Bilirubin Sensor	Sensa Core Medical Instrumentation Pvt. Ltd.	Healthcare	Technology Licensed to M/s Sensa Core
LFIA based strips for detection of bovine mastitis	Prompt Equipment Pvt. Ltd.	Milk Safety	Technology Licensed to M/s PROMPT Equipment's

Further, 8 industrial projects have been initiated with relevant stakeholders including industries as well as Govt. organizations. Under the Phase-II, 7 prototypes have been developed including sustainable sensing platform for electrochemical sensors using sugarcane skin having varied applications from biosensing to heavy metal detection and Li ion-based technology (coin cell) having capacity of > 30 mAH and under field trial. A lab prototype of a pouch cell battery with 350 mAH capacity has also been developed and demonstrated to provide home-grown technological solution for LED lights and power pack applications.

### 3.3.12.2 Next Generation AMOLED Displays, OLED Lighting and OPV Products

The project “Next Generation AMOLED Displays, OLED Lighting and OPV products: Development of disruptive Technologies to enable cost effective electronic component manufacturing in India”, approved by MeitY being implemented by IIT Madras with total budget outlay of INR 41.60 Crore, including MeitY’s Grant-in-Aid amounting to INR 35.32 Crore. The objective of the centre is to demonstrate state- of-the-art AMOLED based displays developed by Fine Metal Mask (FMM) and Closed Space Sublimation (CSS) processes. OPV devices are also being developed for roll-to-roll manufacturing. A laboratory has been developed successfully for state-of-the-art research facility. A clean area has been set up of area around 3000 sq. ft. There are two parts in the clean area. One is of class 100 and the rest of the area is of class 1000. The class 100 area is used for substrate cleaning, which is very crucial for the fabrication. Class 1000 area has all the deposition units and is utilized for AMOLED device fabrication.



**AMOLED Dock system control**

### **3.3.12.3 Establishment of Gallium Nitride (GaN) Ecosystem Enabling Centre and Incubator (GEECI) at Society for Innovation and Development (SID), IISc Bengaluru**

MeitY has awarded the project to Foundation for Science Innovation and Development (FSID), a Section 8 company, IISc Bengaluru for “Establishment of Gallium Nitride (GaN) Ecosystem Enabling Centre and Incubator (GEECI) for High Power and High-Frequency Electronics” at Centre for Nano Science and Engineering (CeNSE), Bengaluru with budget outlay of ₹ 334.29 Crore. The project envisions to nucleate an end-to-end ecosystem for enabling GaN based electronics manufacturing in the country for power and RF electronics. The incubator will be a R&D foundry dedicated to GaN that will function to generate its own IP, generate IP for industries based on their problem definition for a fee and provide foundry services for pilot scale manufacturing. The Objective of the Project is to establish GaN based Development Line Foundry facility for RF and Power applications and to incubate startups and Entrepreneur-in-Residence. The establishment of the Development line has been completed.

The project is expected to meet India’s strategic RF needs and develop devices that can be used to make prototype systems for the emerging 5G and power applications. The established GaN foundry facility as part of the Incubator will help to stimulate the flow of capital and technology, create employment opportunities, promote higher value addition in the electronic products manufactured in the country, especially in RF and power applications, including strategic applications, reduce dependence on imports and give thrust to the Hon’ble Prime Minister’s clarion call for “Aatma Nirbhar Bharat”.

# 4

## CHAPTER

# International Cooperation

### 4.1 Multilateral Cooperation

With the Government's outlook on Digital Diplomacy, Digital Economy and launch of Digital India Program (DIP), MeitY has synergized its efforts to expand Electronics and IT/Software sector globally. This expansion aims to diversify markets, enhance specialized knowledge in various domains, and leverage the expertise of a highly skilled workforce, creating new business avenues worldwide. For the promulgation of the public policy objectives MeitY has been actively working to build strategic alliances with foreign partners, especially in the emerging areas of Information and Communications technology (ICT), through bilateral and multilateral cooperation.

MeitY regularly engages with various foreign governments, academic institutions, and industry bodies to develop partnerships that are mutually beneficial, promoting the exchange of expertise, experience sharing and fostering innovation. The International Cooperation Division (ICD) of MeitY has taken the lead in driving these initiatives, focusing on key areas such as:

- **Supporting National Goals:** Ensuring that all international collaborations align with key government initiatives like 'Digital India' and 'Make in India,' which are central to India's long-term digital transformation and manufacturing objectives.
- **Engaging in Global Forums:** Enhancing India's presence and leadership on international platforms to address key issues such as G20, SCO, BRICS, ASEAN, digital transformation, bridging the digital and gender divides, and strengthening digital governance and infrastructure.
- **Facilitating International Industry Collaboration:** Creating an environment that encourages cooperation between Indian industries and their international counterparts to foster innovation and joint development in cutting-edge ICT solutions.
- **Encouraging R&D Initiatives:** Supporting international research and development partnerships to accelerate advancements in ICT applications, thereby contributing to the development of groundbreaking digital technologies.
- **Coordinating with Global Institutions:** Collaborating with international organizations such as the UN agencies (including UNESCO, UNCTAD, UNDP, ECOSOC, and ESCAP), WSIS, World Bank, WTO, ADB, and the World Economic Forum (WEF). These partnerships help safeguard India's interests and ensure that the country's priorities are represented in global ICT policies and discussions.
- **Spearheading Collaborative Projects:** Launching joint projects with global partners, including establishing IT institutes, software development parks, digital solutions and initiating joint R&D ventures.
- **Promoting India's ICT Expertise:** Showcasing India's ICT strength across various international forums by organizing, sponsoring and participating in trade fairs, symposiums, exhibitions etc.

To achieve these objectives, the ICD, MeitY engages through various mechanisms, such as Memorandums of Understanding (MoUs), Joint Working Group (JWG) meetings, Free Trade Agreement (FTA) and multilateral deliberations/negotiations in the ICT, digital economy and digital trade areas. The ICD also leads India's involvement

in key international events to highlight the potential of Indian IT and software industries. Moreover, the division actively works to address challenges related to the export of Indian IT services and the mobility of IT professionals, representing these issues at global forums.

Through these efforts, MeitY aims to strengthen India's position as a key player in the global digital economy, promoting its ICT capabilities while ensuring that the country's interests and expertise are well-reflected in international collaborations.

To protect its national interests and advance its digital transformation on the global stage, MeitY has been actively engaging with various multilateral forums. These efforts involve collaboration, negotiations, and addressing technical and policy matters with key international forums/organizations like the G20, United Nations, WTO, World Bank, BRICS, SCO, IPEF, QUAD, ASEAN, G7, ADB, BIMSTEC, Commonwealth, IPU, ITU, SAARC, OECD, and others in the IT/Software and electronics sectors.

India's participation in various international forums highlights its commitment to driving digital progress and fostering partnerships with global stakeholders. Through these forums, India showcases its achievements, explores opportunities for collaboration, and strengthens its influence in shaping the global digital economy.

## 4.2 Key Achievements

**South Africa's G20 Presidency 2025:** MeitY represented India in G20 Digital Economy Working Group (DEWG), Artificial Intelligence Task Force (AITF), and Ministerial Meetings under the South African Presidency in 2025. The DEWG meetings focused on discussions and negotiations of the Digital Economy Ministerial Declaration, incorporating the proposed priority areas- Universal and equitable digital inclusion through connectivity, usage, and enabling conditions; Digital Public Infrastructure (DPI) as a key element for digital transformation; digital innovation ecosystems unleashing the potential of Micro, Small and Medium Enterprises (MSMEs); and equitable, inclusive, trustworthy, and sustainable Artificial Intelligence (AI) for good and for all. The AITF meetings focused on deliberations and negotiations of the AITF Ministerial Declaration, which emphasized inclusive, ethical, and sustainable AI development, addressing themes such as human rights-centred AI, digital sovereignty, bias mitigation, open access, information integrity, responsible use of AI, public sector capacity building, and linking AI with sustainability, with data governance as the foundation.

MeitY negotiated the key issues and put forth the DPI and AI agenda agreed under the Indian Presidency in 2023. The Chair's Statement of the Digital Economy Working Group and the Chair's Statement of the Task Force on Artificial Intelligence, Data Governance and Innovation for Sustainable Development were ultimately adopted during the Digital Economy Ministers' Meeting (DEMM) and the Ministerial Meeting of the AI Task Force, respectively, on September 29-30, 2025 at Cape Town, South Africa, reaffirming the priorities of the Working Group and the Task Force and strengthening commitments on the proposed deliverables.

**WEF's Annual Meeting 2025:** The 55<sup>th</sup> World Economic Forum (WEF) Annual Meeting held in Davos, Switzerland, from January 20–24, 2025, provided a significant platform for India to showcase its digital initiatives and strengthen global partnerships in the technology sector. The Hon'ble Minister of Electronics and Information Technology, Shri Ashwini Vaishnaw led the Indian delegation and participated in several sessions and roundtable discussions with global political and business leaders. The Minister underscored India's strategic vision of leveraging digital and physical infrastructure, semiconductor and electronics manufacturing, and inclusive innovation to drive economic growth. India's leadership in Digital Public Infrastructure (DPI) and responsible AI development was also highlighted.

**WTO Public Forum 2025:** Session on DPI – Driving Trade, & Development: MeitY, in collaboration with the Permanent Mission of India (PMI) to the WTO, Geneva organized a session on “Digital Public Infrastructure – Driving Trade and Development” during the WTO Public Forum 2025 at Geneva. The session showcased India's DPI journey, from AADHAAR and the JAM Trinity (Jan Dhan, AADHAAR, Mobile) to initiatives such as UPI, DigiLocker, ONDC, and the

proposed Bharat TradeNet, highlighting how DPI serves as a catalyst for trade facilitation and sustainable development. Joint Secretary (ICD), MeitY, participated in the session and delivered remarks on India's experience in leveraging DPI to promote inclusive growth and foster global digital cooperation. India called for WTO key role in promotion of digital technologies including DPI for the global trade and economic development.



#### **UN-CSTD Working Group on Data Governance (WG-DG) Meetings:**

The Global Digital Compact (GDC), adopted by UN Member States on 22 September 2024, led to the establishment of a dedicated Working Group on Data Governance (WG-DG) by the United Nations Commission on Science and Technology for Development (UN-CSTD) to facilitate an inclusive, multi-stakeholder dialogue on data governance at all levels relevant to development. India serves as a member representing the Asia-Pacific Regional Group. As a member, MeitY has actively participated and proactively contributed to all meetings of the UN-CSTD WG-DG.

Conference on Digital Public Infrastructure (DPI) for Digital Transformations organized jointly by PMI-India and the International Telecommunication Union (ITU) on at the UN Headquarters in Geneva, the conference focused on the future of Digital Public Infrastructure (DPI) and the role of emerging technologies in transforming governance. Shri S. Krishnan, Secretary, MeitY participated and shared insights on India's DPI journey and the potential of citizen-centric digital innovation in promoting inclusive digital economies.

#### **United Nations Commission on International Trade Law (UNCITRAL): 68<sup>th</sup> & 69<sup>th</sup> Session of Working Group IV (Electronic Commerce)**

The 68<sup>th</sup> session of the UNCITRAL Working Group IV (Electronic Commerce) was held in New York from 24 to 28 March 2025 and 69<sup>th</sup> session was held in Vienna, Austria from 20 to 24 October, 2025. The sessions focused on formulating default rules on data provision contracts aimed at facilitating cross-border data flows. MeitY participated in both the sessions and contributed to the discussions on the draft default rules on data provision contracts.

#### **United Nations Economic and Social Commission for Asia and the Pacific (UNESCAP): 20<sup>th</sup> Session of the Governing Council of the Asian and Pacific Training Centre for Information and Communication Technology for Development (APCICT)**

United Nations Economic and Social Commission for Asia and the Pacific (UNESCAP) is the regional development arm of the United Nations for the Asia-Pacific region. UNESCAP represents a common forum for countries of the region with 53 members including China, Indonesia, Japan, Republic of Korea, Singapore, UK and many developing and Least Developed Countries to build capacities and share experience in the field of using ICT for development. APCICT is the regional institute of the UNESCAP formed to strengthen the efforts of the member countries of ESCAP to use the ICT in their socio-economic development.

The 20<sup>th</sup> session was held at Incheon, Republic of Korea on 5<sup>th</sup> November 2025, to review the administrative and financial status of the Centre, progress of implementation of the Centre's flagship programmes, outcome of independent evaluation and work plan for 2026, and discuss the ICT capacity-building needs in Asia and Pacific alongwith the discussion on priority areas for Centre's future programme of work. MeitY participated in the session and contributed to discussions on acceleration of digital transformation in Asia and the Pacific through its flagship ICT capacity building initiatives.

### **United Nations Educational, Scientific, and Cultural Organization (UNESCO): 43<sup>rd</sup> General Conference (GC)**

UNESCO is a specialized agency of the United Nations that works to build peace and sustainable development through international cooperation in education, science, culture, and communication. It supports Member States by setting global norms, promoting knowledge sharing, protecting cultural and natural heritage, and strengthening national capacities through policy guidance and programmes.

The UNESCO General Conference is the organization's highest decision-making body, comprising all Member States, which meets biennially to set overall policies and priorities, approve the programme and budget, adopt conventions, and elect the Executive Board and Director-General

The 43<sup>rd</sup> General Conference (GC) of UNESCO was held in Samarkand, Uzbekistan from 30 October to 13 November 2025. MeitY participated in the Social and Human Sciences (SHS) and Communication & Information (CI) Commission meetings of the General Conference on 5–6 November 2025 and presented India's stance on various ICT issues.

## **4.3 Bilateral Cooperation**

With the Government's outlook on Digital diplomacy, Digital Economy and the launch of the Digital India Programme, MeitY has synergized its efforts to expand the IT and electronics sector globally including diversification of geographies, domain expertise, and highly skilled workforce to enhance business opportunities. Efforts have also been made to evolve strategic cooperation with potential foreign partners in emerging and frontier areas of Information and Communication Technology. The Ministry regularly engages with various Governments including academic and industry bodies to forge partnerships for mutual progress, and also provide an opportunity for the sharing of knowledge and experience. The International Cooperation Division has been involved in the following tasks:

- Aligning foreign collaboration activities in India's 'Digital India program' and 'Make in India' initiatives of the Government of India.
- Creating a conducive environment for international cooperation to help industries to cooperate with the industries of other countries.
- Fostering, encouraging and promoting research and development in the application of information technology related facilities.
- Initiating joint projects like IT institutes, software parks, programmes for joint R&D and facilitating IT Advisers etc.
- Showcasing India's ICT strength across the globe by organizing, sponsoring and participating in trade fairs, symposiums, exhibitions etc.

The International Cooperation Division of this Ministry has been pursuing the above objectives through Memorandum of Understanding (MoUs), Joint Working Groups (JWG) meetings, Projects in other geographies/ countries, participating in major international events to showcase India's strength and enhance business opportunity for Indian IT Industries. The division has also spearheaded the negotiations on Digital Trade chapter under various forums/ Free Trade Agreements (FTAs).

To strengthen cooperation with other emerging economies, the MoUs/ Agreements in the field of Digital technologies and Semiconductor were signed with Indonesia, Thailand, Japan, Philippines and Netherlands. Further, in order to expand India's Digital capabilities in Digital Public Infrastructure (DPIs), MeitY has signed MoUs on cooperation in the field of sharing successful digital solutions implemented at population scale for digital transformation with 5 countries – Venezuela, Sri Lanka, Brazil, Lesotho and Maldives. Under the signed MoUs, several virtual technical workshops have held to explore areas of cooperation.

#### 4.4 Major bilateral engagements

1. A bilateral meeting between Hon'ble Minister of Electronics and Information Technology, and Executive Vice-President for Technological Sovereignty, Security, and Democracy, European Commission, was held on February 27, 2025 in New Delhi. Discussions focused on strengthening India-EU cooperation in key areas such as microelectronics and supply chain resilience, AI, DPI, high-performance computing and quantum technology, digital skills, and telecom and IT standardization.
2. A bilateral meeting under Working Group-1 of the India-EU Trade and Technology Council (TTC) on Strategic Technologies, Digital Governance, and Digital Connectivity was co-chaired by Secretary, MeitY, from the Indian side, and DG CNECT, European Commission, on February 28, 2025. Discussions focused on enhancing India-EU collaboration in safe and trusted AI, interoperable DPI standards, creating resilient semiconductor supply chains, and aligning research and development priorities in telecom. Both sides reiterated their commitment to strengthening the India-EU partnership.
3. The Second Meeting of the India-EU TTC was held in New Delhi on February 28, 2025. Hon'ble Minister for Electronics and Information Technology, participated as a co-chair on the Indian side, along with India's External Affairs Minister, and Commerce and Industry Minister. The EU side was co-chaired by Executive Vice-President for Tech Sovereignty, Security and Democracy, Commissioner for Trade and Economic Security, Interinstitutional Relations and Transparency, and Commissioner for Startups, Research and Innovation. The co-chairs reaffirmed their commitment to expanding and deepening engagement under the TTC.
4. A bilateral meeting between Group Coordinator (R&D), MeitY, and a delegation from the Department of Science, Innovation and Technology, UK, was held on March 13, 2025, in MeitY. Discussions were held regarding compound semiconductors, microelectronics and supply chain resilience, research and development, and skilling.
5. The Second Meeting of the India–South Africa Joint Working Group (JWG) on Information, Communication and Technology (ICT), co-chaired Joint Secretary, MeitY, from the Indian side, and Acting Deputy Director General, ICT International Relations and Trade, DCDT, from the South African side, was held in Pretoria, South Africa, from March 26–28, 2025. Discussions were held regarding cooperation in the areas of Digital Public Infrastructure, digital payments ecosystem, artificial intelligence, startup ecosystem, digital skills, and IT/ITeS.
6. A bilateral meeting between Secretary, MeitY, and State Secretary, Federal Ministry for Digital and Transport (BMDV), Germany, was held on April 9, 2025, in MeitY. Discussions focused on advancing strategic cooperation in resilient and diversified supply chains with emphasis on collaboration in AI, research and development, digital skilling, and Digital Public Infrastructure.



7. A delegation led by Secretary, MeitY, visited the Netherlands from April 28–29, 2025. During the visit, meetings were held with Secretary General, Ministry of Economic Affairs, and Director General for Foreign Economic Relations, Netherlands. The delegation also held interactions with leading companies and institutions including NXP Semiconductors, Philips, HighTech NL, Dutch Research Council (NWO), ASML, and Quantum Delta, and visited the ASML Experience Center and the Quantum research facilities at TU Delft. Discussions focused on exploring collaboration in semiconductors and related emerging technologies.
8. A Young Leaders' delegation from various political parties of Nepal to India visited MeitY for an interaction with Secretary MeitY on August 4, 2025. Secretary MeitY briefed the delegation about India's initiatives regarding Digital Public Infrastructure, Electronics Manufacturing Ecosystem in India, IndiaAI Mission, Capacity building programs and Cyber Security etc.



9. India–Singapore Joint Working Group on Digital Technologies was held in virtual mode on August 6, 2025. The key agenda items included cooperation in Digital Public Infrastructure, collaboration opportunities involving DigiLocker, cross-border verification of educational certifications, mutual recognition of e-signatures, sharing best practices in data governance and AI, UPI–PayNow linkage, and collaboration between industry and startups.
10. The first meeting of the Malaysia–India Digital Council (MIDC), co-chaired by Secretary, MeitY, from the Indian side, and Secretary General, Ministry of Digital, from the Malaysian side, was held on August 26, 2025, in virtual mode. Discussions focused on cooperation in artificial intelligence, digital public infrastructure, digital talent, and cybersecurity.
11. A meeting between Secretary, MeitY, and Hon'ble Vice Minister for the Development of Information and Communication Technologies, Venezuela, was held on September 16, 2025, in MeitY. Discussions were held regarding DigiLocker proof of concept and further cooperation under the signed MoU on sharing successful Digital Solutions between the Ministry of Electronics and Information Technology, India, and the Ministry of People's Power for Science and Technology, Venezuela.
12. The Working Group-1 of the India-EU Trade and Technology Council (TTC) on Strategic Technologies, Digital Governance and Digital Connectivity met on October 31, 2025 to discuss digital priorities ranging from semiconductors, digital public infrastructure, and digital skills to AI, high performance and quantum computing, and IT and telecom standardisation. The meeting was co-chaired by the Secretary, MeitY and the Director-General, DG CNECT.



13. A delegation, led by the Secretary, MeitY, visited the United Arab Emirates to participate as a speaker at the Abu Dhabi Global AI Summit during 2–3 November 2025.

- 14 The inaugural meeting of the India – Mauritius Joint Working Group (JWG) on Information and Communication Technology (ICT) was held in virtual mode on November 6, 2025. The meeting was co-chaired by Joint Secretary, ICD, MeitY and Hon'ble Minister for Information Technology, Communication and Innovation, Mauritius. The discussions focused on key areas of cooperation, including Digital Governance, Digital Public Infrastructure (DPI) including DigiLocker, Digital Payments, Digital Skilling, Cyber Security, and Artificial Intelligence.
- 15 The 3rd meeting of the India – Uzbekistan Joint Working Group (JWG) on Digital Technologies was held in virtual mode on November 7, 2025. The meeting was co-chaired Joint Secretary, ICD, MeitY and Hon'ble Deputy Minister, Ministry of Digital Technologies, Uzbekistan. Both sides deliberated on key agenda items, with a focus on cooperation in the area of Digital Public Infrastructure (DPI), including DigiLocker, digital skilling, and potential collaboration in the IT sector regarding IT parks.

# 5

## CHAPTER

# Innovate and Design in India

## 5.1 Artificial Intelligence & Emerging Technology

### 5.1.1 Promoting the Adoption of Cutting-edge Technologies to Create Significant Economic and Societal Impact

India is now prepping for cutting-edge technologies including 5G, AI, blockchain, augmented reality & virtual reality, machine learning & deep learning, robots, natural language processing, etc. These will be critical in the government and industry, for planning or decision-making, expediting development or analyzing deployment, issue solving or product creation, detecting new trends or drawing out linkages and associations. The Emerging Technologies Division of MeitY is responsible for fostering and promoting the utilization of cutting-edge technologies in the country. The Emerging Technologies Division is supporting work for policy/strategy papers in emerging areas like AI, AR/VR, IoT, blockchain, robotics, computer vision, drones, etc.

#### Initiatives by MeitY in Emerging Technologies

- **Centres of Excellence for Internet of Things (Gandhinagar, Bengaluru, Gurugram & Vizag)**

Under the Digital India initiatives, MeitY along with NASSCOM and state governments has set up Centres of Excellence on Internet of Things at Bengaluru, Gurugram, Gandhi Nagar and Visakhapatnam. First Centre on IoT was established in Bengaluru in 2016 along with the Government of Karnataka and NASSCOM. One of the objective of these centres was to enable India to emerge as an innovation hub in IoT through democratization of innovation and realization of prototypes. The CoE, supported by Government and industry is a nationwide platform for innovation sandbox to enable technology adoption and innovation, and to develop a culture of cocreation in Industry 4.0, manufacturing, automotive and transportation, lifesciences and healthcare, agriculture and other industry verticals and horizontals. More than 551 startups have been enrolled, 96 societal projects have been undertaken, and 116 IPs generated.

- **Centre of Excellence on Virtual & Augmented Reality (VARCoE) at IIT Bhubaneswar:**

Virtual Reality and Augmented Reality (VR and AR) have massive innovation potential across a wide range of industries and research fields. With an objective to explore the opportunities in this niche area, Software Technology Parks of India in partnership with MeitY, Government of Odisha, IIT Bhubaneswar and a philanthropist has established Centre of Entrepreneurship for Virtual and Augmented Reality (VARCoE) at IIT Bhubaneswar. VARCoE undertakes worldclass research, develop state-of-the-art testing facility/laboratories for advanced algorithms, applications and methods in aid of AR & VR for immersive visualization in areas including skill development, product design, healthcare, art & architecture, transport, construction, tourism, entertainment, education & productivity software. Presently nine major projects on AR&VR applications in various domains involving 12-15 highly qualified faculty and researchers of IIT Bhubaneswar are in progress. VARCoE has also supported 32 startups so far.

- Centre of Excellence on Gaming, VFX, Computer Vision & AI at Hyderabad:**

This CoE has been set up in collaboration with MeitY, STPI, the gaming industry and the Govt of Telangana in Jan 2020 to provide resources such as mentoring, technology support and funding for gaming, animation, VFX, computer vision and AI start-ups. It offers integrated programs, CVLAB and Game Lab for start-ups to scale up through its incubation facility. The centre has been branded as IMAGE. The IMAGE accelerator program includes premium plug and play co-working space for start-ups and offers access to the ecosystem which comprises IP owners, mentors, seed funding, investors and a platform to support Go-To-Market strategy. At present 97 start-ups have been on-boarded and so far, 220 products & 108 IPRs have been created.

- Centre of Excellence on Blockchain Technology at Gurugram:**

The STPI APIARY, a Centre of Entrepreneurship in Blockchain Technology has been setup in collaboration with MeitY, STPI, Govt. of Haryana, Padup Venture Private Limited, IBM, Intel, GBA and FITT in March 2020. This is an initiative to identify and evaluate promising start-ups in the field of Blockchain technology that will be hosted in the STPI Gurugram incubation facility. The CoE is created to be an Incubation-cum-Accelerator Programme through which acute challenges faced by start-ups from validation of idea to initial investment will be addressed. Total 43 start-ups have been onboarded and so far, 43 products & 06 IPRs have been created.

- Design, Development, and Deployment of National AI Portal (INDIAai Portal):**

The National AI Portal of India (INDIAai) has been set up to prepare the nation for an AI future. This has been implemented as a one stop online portal for AI related developments in India, sharing of resources, details of start-ups, investment funds in AI, companies and educational institutions related to AI in India, etc. The portal currently has the following major sections – news, articles, case studies, research reports, listing of startups, listing of investment funds, colleges, companies, countries, people, videos, datasets, courses, and initiatives of states and central ministries. As on date, there are 3647 national and international articles, 1314 news, 366 videos, 171 research reports, 512 startups, 151 case studies, and 172 government initiatives listed on the National AI Portal.

- POC for AI Research Analytics and Knowledge Dissemination Platform (AIRAWAT)) & PARAM Siddhi-AI:**



A flagship initiative of Govt of India, steered by the Ministry of Electronics and Information Technology (MeitY), AIRAWAT-PARAM Siddhi AI (AIRAWAT-PSAI) is a converged HPC-AI dense GPU infrastructure designed & commissioned by Centre for Development of Advanced Computing (C-DAC). AIRAWAT-PASI is integrated platform for Artificial Intelligence (AI), providing a comprehensive framework for developing, training, and deploying AI models.

The system is having peak computing capacity of 13.17 PetaFlops (410 AI PF). With recent upgrade, the total compute capacity of AIRAWAT-PSAI stands at 538 AI PF (17.48 PF HPC)

This AI computing infrastructure connects Centres of Research Excellence in AI, Indian Centres for Transformational AI, Academic, Research Labs, Scientific Community, Industry MSMe and Start-ups.

1300+ users, including 90+ startups from 240+ Institutes/Organization across India, are part of AIRAWAT-PSAI user community. More than 300+ projects are associated with AIRAWAT -PSAI and more than 300K workloads are executed on the system.

- **IndiaAI Mission:**

The Government of India launched the IndiaAI Mission, a comprehensive national level program to democratize and catalyze the AI innovation ecosystem in the country and ensure the global competitiveness of India's AI startups and researchers.

The Mission aims to establish a robust AI ecosystem through strategic programs and partnerships across the public and private sectors. By democratizing computing access, improving data quality, developing indigenous AI capabilities, attracting top AI talent, enabling industry collaboration, providing startup risk capital, ensuring socially impactful AI projects and bolstering ethical AI, it will drive responsible, inclusive growth of India's AI ecosystem. The Mission is being implemented by 'IndiaAI' Independent Business Division (IBD) under Digital India Corporation (DIC) through the seven key pillars: IndiaAI Compute Capacity, IndiaAI Foundation Models, AIKosh (IndiaAI Datasets Platform), IndiaAI Application Development Initiative, IndiaAI FutureSkills, IndiaAI Startup Financing, and Safe & Trusted AI.

This Mission will propel innovation and build domestic capacities to ensure the tech sovereignty of India. It will also create highly skilled employment opportunities to harness the demographic dividend of the country and help India demonstrate to the world how this transformative technology can be used for social good and enhance its global competitiveness. The Mission has been able to:

- (i) High-end AI compute infrastructure with over 38,000 GPUs and 14 cloud partners established.
- (ii) Democratize access to AI Datasets through AIKosh with 3,011 datasets and 243 AI Models onboarded from 39 organisations across 20 sectors such as agriculture, health, water, governance, rural development, urban infrastructure, commerce, environment, aquaculture, etc.
- (iii) Initiated the development of indigenous foundational models and multilingual LLMs & SLMs with 12 partners (Sarvam AI, Soket AI, Gnani AI, and Gan AI, Avaatar AI, IIT Bombay consortium – BharatGen, Zenteiq, Gen Loop, Intellihealth, Shodh AI, Fractal Analytics, Tech Mahindra Maker's Lab).
- (iv) Expand AI skilling programs and creating pathways for entry level with Fellowship programs to support 500 PhD fellows, 8,000 undergraduate students, and 5,000 postgraduate students across a variety of disciplines, and setting up of 570 Data and AI Labs in tier 2 and 3 cities.
- (v) 200+ fellowships awarded to UG/PG students and 28 PhD scholars onboarded across 17 research institutes.
- (vi) 27 IndiaAI Data & AI Labs operational through NIELIT centers, aiming to upskill 10,000+ students in three years; 4 IndiaAI labs in partnership with an Industry partner, established in Delhi, Mohali, Mhow, and Mokokchung.
- (vii) 30 AI solutions under development across 14 themes in 5 key sectors: Climate, Disaster Management, Healthcare, Agriculture, and Governance.
- (viii) Sectoral hackathons and AI challenges launched with partners including the Indian Cybercrime Coordination Centre, Geological Survey of India, and National Cancer Grid to further encourage focused AI solution development.

- (ix) 10 startups supported for international growth and mentorship through partnerships with Station F and HEC Paris.
- (x) 13 projects initiated in AI governance frameworks to ensure adequate guardrails for protecting the safety, security, and trust of citizens by AI safety institutions have been initiated.

- **AI Impact Summit 2026:**

India will host the AI Impact Summit in February 2026 at Bharat Mandapam, New Delhi, as a global convening to shape the future of inclusive, responsible, and resilient Artificial Intelligence (AI). Building on the momentum of previous multilateral initiatives including the Bletchley Park, Seoul, Paris, and Kigali Summits, the AI Impact Summit is envisaged to mark a shift from aspirations to impact, demonstrating how AI can deliver tangible outcomes for *People, Planet, and Progress*. As the first Global AI Summit of this series to take place in the Global South, the Impact Summit will advance a future where the transformative impact of AI serves humanity, advances inclusive growth, fosters social development, and promotes people-centric innovations that protect our planet. The Summit builds on extensive groundwork, including five rounds of public consultations and global outreach sessions in Paris, Berlin, Oslo, New York, Geneva, Bangkok, and Tokyo. Regional events across India have ensured grassroots voices are represented, while over 150 affiliated Pre-Summit Events worldwide have generated actionable insights and broadened participation. Complemented by curated consultation sessions for the flagship events and working groups, these efforts reflect India's deeply participatory approach to the Impact Summit.

### 5.1.2 Quantum Technology

C-DAC is executing various projects of national importance in the areas of Quantum technologies. These initiatives are aimed at development of indigenous R&D capabilities and fostering a strong ecosystem in this critical technology sector. Various initiatives have been taken in the areas of Quantum computing, Quantum communication, and building a secure Post Quantum Public Key Infrastructure.

- **Establishment of Superconducting based Quantum Computing Reference Facility:** The Ministry of Electronics and Information Technology (MeitY) has initiated a project titled "Establishment of a Superconducting-based Quantum Computing Reference Facility" to accelerate research and development in quantum technologies, enhance national capabilities, and strengthen industry participation. The project envisions the creation of a state-of-the-art quantum computing facility in the country, equipped to tackle advanced scientific and industrial challenges through quantum computation. A superconducting quantum computer with 50–100 qubits will be established including cryogenic cooling systems, precision control electronics, and specialized software. The facility will feature cloud-based access, enabling researchers and industry professionals to perform quantum experiments remotely. Beyond infrastructure development, the initiative focuses on capacity building and collaboration, aiming to train hundreds of skilled professionals and promote partnerships between academia and industry. Through these efforts, the project seeks to position India at the forefront of global quantum technology research and innovation.

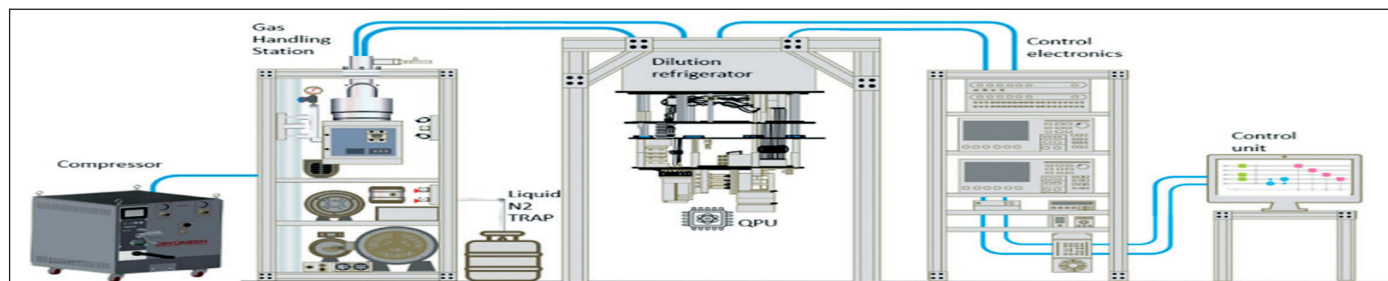

Reference Facility Set-Up

- HPC based Quantum Accelerators for enabling Quantum Computing on Supercomputers:**

The Quantum Accelerator project, initiated by the Ministry of Electronics and Information Technology (MeitY), is an effort to develop a quantum computing simulator platform, using high-performance computing capabilities of existing PARAM supercomputers. Its primary objective is to expedite the execution of quantum algorithms, harnessing the processing power of GPU, Vector, and FPGA cards, with a notable demonstration featuring the state-of-the-art Rudra GPU board.

A unified quantum computing platform, Qniverse, has been developed to provide seamless management, visualization, and execution of quantum workloads across simulators, accelerator testbeds (Vector, FPGA, GPU), and quantum hardware backends, establishing a versatile ecosystem for quantum-HPC integration. Also, QARN (Quantum Accelerated and Reconfigurable Noisy simulator), a GPU-accelerated simulator, has also been developed and is capable of simulating up to 28 qubits with significant performance improvements. Quantum Accelerators provides a platform to students, researchers, software developers, start-ups to innovate and implement their idea of Quantum Computing on Quantum Accelerators.

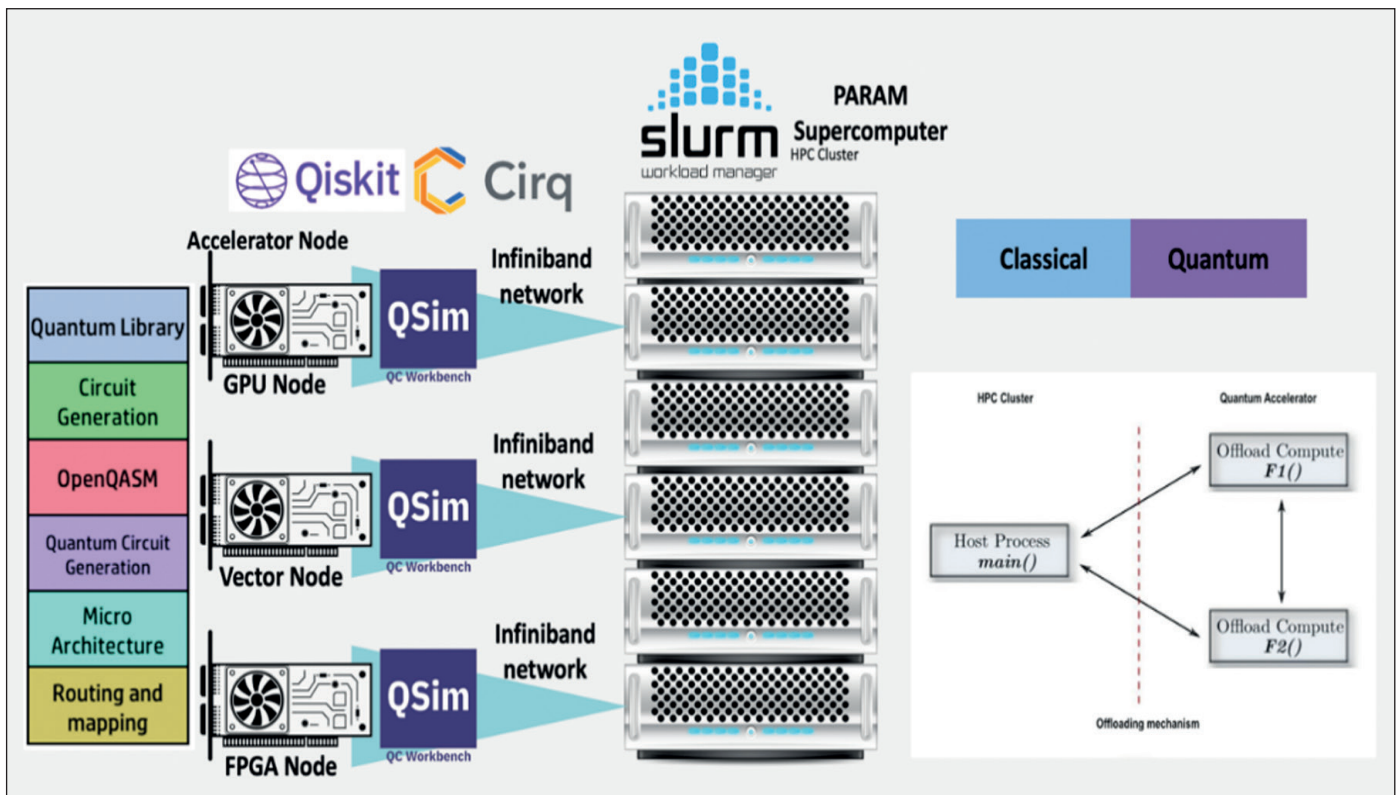

Quantum Accelerator Architecture

- FinTeQ - Quantum-Safe Financial Transaction Framework:** The project is being implemented to develop a quantum-safe financial transaction framework to secure financial transactions against emerging quantum threats that could compromise existing cryptographic systems such as RSA, ECDSA, and AES. The framework adopts a dual approach—leveraging fiber-based Quantum Key Distribution (QKD) for secure symmetric key exchange in B2B financial transactions, and deploying indigenously developed Secure USB Dongles, built on SCOSTA-OS and compliant with PKCS#7 and PKCS#11 standards, for enhanced authentication in B2C and C2C transactions across web and mobile platforms. This initiative strengthens the security of financial transactions with quantum technology.

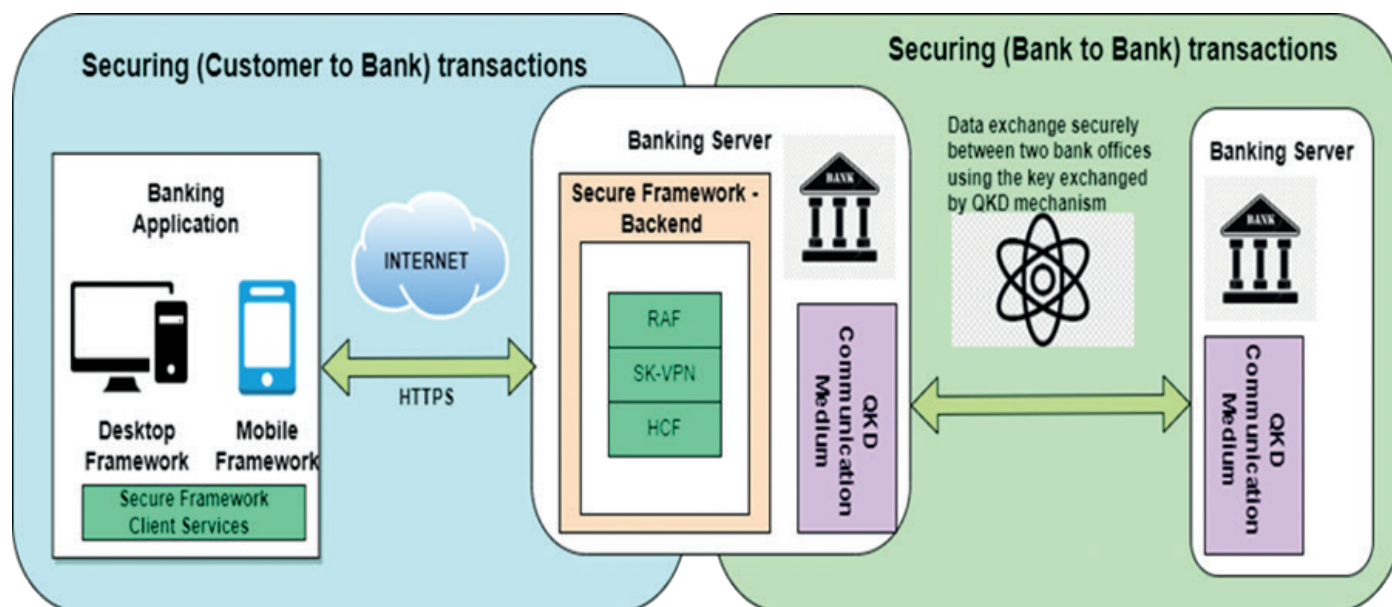

FinteQ Framework

- Development of Secure Post Quantum Public Key Infrastructure:** The emergence of quantum computing poses a significant threat to the security of existing Public Key Infrastructure (PKI), as widely deployed public-key cryptographic algorithms are vulnerable to quantum attacks. To address this challenge, the Ministry of Electronics and Information Technology (MeitY) has initiated the project “Development of Secure Post-Quantum Public Key Infrastructure (PQ-PKI)”, aimed at enabling PKI systems based on Post-Quantum Cryptographic (PQC) algorithms and ensuring long-term cryptographic security in the quantum era.

Under this project, Post-Quantum Crypto Tokens are being developed using CRYSTALS-Dilithium for digital signature schemes and CRYSTALS-Kyber for key encapsulation mechanisms. These algorithms have been selected by the National Institute of Standards and Technology (NIST) as standardization candidates (winners) under its Post-Quantum Cryptography program. In addition to adopting standardized PQC algorithms, the project also envisages the design and development of new indigenous Post-Quantum Cryptographic algorithms.

The selected PQC algorithms are being implemented on hardware platforms (FPGA) and a Post-Quantum based Crypto Dongle will be designed to provide high assurance and resilience against both classical and quantum adversaries. The Certificate Authority (CA) software suite is being enhanced to seamlessly integrate with the Post-Quantum Crypto Token, enabling end-to-end PQC-enabled PKI services.

The developed solution would significantly strengthen the security of PKI systems against quantum-enabled attacks. Key deliverables under the project include FPGA implementations of CRYSTALS-Kyber and CRYSTALS-Dilithium, a PQC-based Document Signer application, a PQC soft token, CA software suite enhancements compliant with IVG guidelines, and a Post-Quantum Cryptography-enabled TLS cipher suite.

- Quantum Machine Learning Use Cases and Applications:** MeitY has initiated a project envisioning the establishment of a robust quantum research and development ecosystem that drives long-term innovation in quantum machine learning (QML) and its real-world applications. The project is being implemented by CDAC (Hyderabad, Mohali, Noida, Delhi, CINE), IIT (Roorkee, Ropar, Gandhinagar) and IIIT Hyderabad. The project aims to Develop Quantum Machine Learning Applications which could leverage quantum advantage in solving complex problems in areas of healthcare, geology, surveillance, cyber security, emergency management, remote sensing and chemistry. Another major activity in the project includes capacity building of more than 700

manpower in the country in the areas of Quantum Computing and Quantum Machine Learning. By fostering a skilled workforce and encouraging collaborations with startups and industries, the project will drive the growth of a self-sustaining quantum ecosystem in India. Advanced quantum machine learning methods are being tried to mineral prospectivity and brain tumor analysis. Hybrid quantum-classical ensemble models are being developed for these challenges. A Quantum Neural Network (QNN) is being developed for dynamic road path optimization during natural disasters. New quantum algorithms were also developed for intermediate-term quantum computers.

- Enabling Secure Boot in RISC-V Processors using Post Quantum Secure Schemes:** In light of the advancements in quantum computing, it is crucial to migrate to post-quantum schemes in various environments, especially for applications like secure booting. MeitY has initiated a project with the objective to demonstrate the secure boot functionality in a RISC-V environment, using both classical and post-quantum secure cryptographic schemes, alongwith on-chip keys generation. The project is being implemented by SETS Chennai and C-DAC Thiruvananthapuram focuses on developing three secure boot environments specific to RISC-V architecture, one based on Edwards-curve Digital Signature Algorithm (EdDSA), another on eXtended Merkle Signature Scheme (XMSS3), and third using Cryptographic Suite for Algebraic Lattices (CRYSTALS)-DILITHIUM or MAYO. Software implementation of EdDSA Scheme on VC707 FPGA board has been carried out. The task of integrating EdDSA with secure boot functionality of RISC-V based VEGA processor built by C-DAC using FPGA is under progress.
- Development of a Quantum optical sensor based system to identify and categorize Arsenic and Lead in water even with very low concentration:** Identification of ultra fine trace elements in water, packaged food, etc. is a crucial societal need. However, existing measurement techniques face limitations in resolution. A research project was implemented for the development of a quantum sensor-based array device for grading the quality of usable water, primarily for drinking purposes by CDAC Kolkata and Tezpur University, Assam. The team has synthesized and characterized sensing material  $\text{Fe@rGO}$  and  $\text{Fe}_3\text{O}_4@\text{SiO}_2$  for detecting arsenic (As) and lead (Pb) respectively. The research team has created special sensing materials,  $\text{Fe@rGO}$  for detecting arsenic and  $\text{Fe}_3\text{O}_4@\text{SiO}_2$  for detecting lead. The team has developed an IoT-enabled fibre-based sensor system that connects to the cloud and works with the same sensing materials, allowing remote monitoring and real-time data access
- Design and Development of a Unified Blockchain Framework (UBF) for offering National Blockchain Service and creation of a Blockchain Ecosystem:** Blockchain, a distributed ledger technology, enables a layer of trust and eliminates the need for a third party to validate the transactions. Considering the requirement for shared blockchain infrastructure, MeitY implemented a project for designing and developing a Unified Blockchain Framework (UBF) to offer National Blockchain Service and create a blockchain ecosystem, jointly executed by C-DAC (Hyderabad, Pune, Mumbai), NIC, SETS Chennai, IIT Hyderabad, IIIT Hyderabad, and IDRBT Hyderabad. MeitY launched the Vishvasya Blockchain Technology Stack in September 2024 to provide Blockchain-as-a-Service (BaaS). It supports distributed infrastructure, smart contracts, security, privacy, interoperability, and permissioned blockchain application development. MeitY has also developed and deployed various use cases with government agencies under the UBF. NBFLite, a lightweight version of Vishvasya, has also been developed to support rapid prototyping, research, and experimentation for academia and startups. NBFLite is available for download from <https://blockchain.meity.gov.in> after registration. A Portal <https://blockchain.meity.gov.in/> has also been developed with sections covering blockchain-related articles, education & training programmes, success stories, latest information, startup details and use cases. The project has so far resulted in the filing of 5 patents and the publication of 51 research papers in reputable journals.
- Bharat DB:** Databases are essential for delivering modern services, yet most commercial and open-source platforms come from international vendors, creating external dependency. To address this, MeitY has initiated a research project to develop an indigenous, secure, resilient, and reliable database platform supporting native

Indian languages. This is being implemented jointly by IIT Madras, IITM Pravartak, and CDAC Chennai. BharatDB aims to build a robust database ecosystem, strengthen security and reliability and drive digital transformation. BharatDB, a secure, scalable, and modular database platform forked from PostgreSQL 17.4, is being designed for enterprise and government workloads. Two beta versions have been developed with several new and improved features: Beta 1 included database upgrade validation, role-based auditing, log analysis, job scheduling, vector support, and single sign-on, while Beta 2 added SSL by default, multi-factor authentication, enhanced auditing, distributed DB with load balancing, and real-time monitoring. It has undergone customer testing to confirm its stability and readiness for production. Beta 3 version is currently in development with further enhancements, and performance benchmarking is ongoing. The pilot deployment of Bharat DB has been carried out at STPI and City Union Bank.

- Open Challenge Competition for Development of “Indian Web Browser with built-in CCA India Root Certificate:** The Indian Web Browser Development Challenge (IWBCD) was launched as a national open challenge to foster the development of secure, standards-compliant, and India-centric web browsers. The initiative focused on incorporating critical indigenous capabilities such as a built-in CCA India Root Certificate, native in-browser digital signing, support for all official Indian languages, parental controls, web filtering, and other essential modern browser features. Through a rigorous multi-stage evaluation process, the challenge successfully resulted in the development of three finalist browsers, each implementing the mandated indigenous features while leveraging open-source browser engines as their foundational platforms.
- Indigenous Intelligent and Scalable Neuromorphic Multi Chip for AI Training and Inference Solutions:** MeitY initiated a research project at IIT Hyderabad, aimed to design and develop an indigenous neuro-morphic architecture for AI training and inferencing. The project progresses from FPGA prototyping to System on Chip (SOC) realization, leading to fabrication of a MCM (Multi-Chip Module) module which comprises multiple SOCs. The team has demonstrated various applications such as image classification, object detection etc on the FPGA prototype. The first Chip Tapeout using TSMC 65nm has been completed. Optimization efforts to enhance performance, reduce power consumption, minimize chip area, memory integration etc. have been carried out. The first AI chip was launched at the T-Chip Semicon Constitution Summit 2025 held in Hyderabad.
- Development of computational protocols for designing inhibitors using PARP-1:** Breast cancer is the most common type of cancer among the Indian population, with lack of awareness and high cost of treatment leads to lower reporting of illnesses. Poly Adenosine Diphosphate Ribose polymerase (PARP-1) inhibitors are among a few handfuls of targets which play an efficient role in treating breast cancer. A project was initiated at NIPER, Guwahati for the development of computational protocols for designing inhibitors using PARP-1 as a model and synthesis & biological evaluation of designed inhibitors. Machine Learning models for prediction of PARP-1 activity have been designed and deployed as a web-server-based GUI. The work has led to publications in high-impact journals and development of two webtools: one for assessing drug synthesis routes and another for the prediction

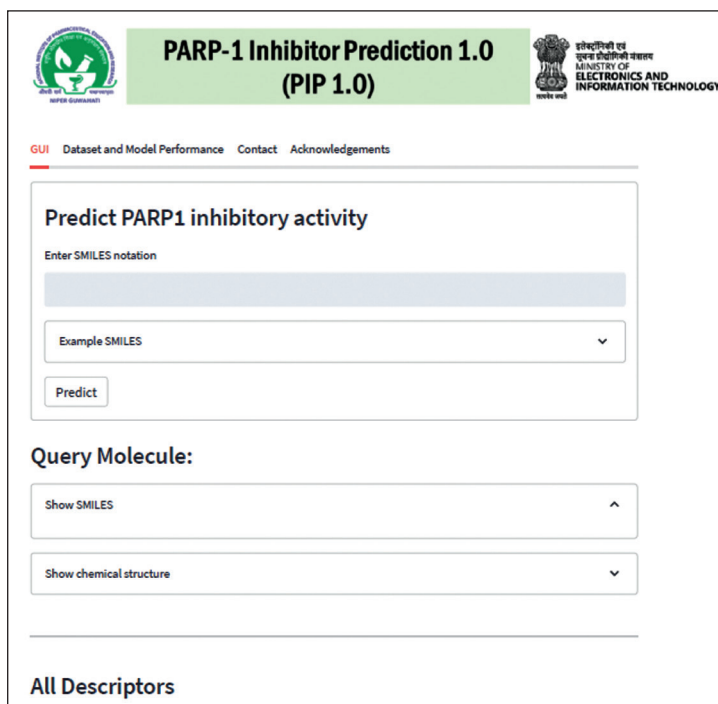

of PARP-1 inhibitors. Consequently, these tools have been granted copyrights. An Advance Centre for Computer-Aided Drug Design (ACAD) which utilizes (Param Embryo HPC supercomputing facility) at NIPER Guwahati was established. A cancer research database was also created to be used for further research works. The team also generalized methods and protocols to other applicable targets such as TKNS-I

- AI augmentation and implementation of e-Saadhya platform for PAN India technology empowerment of Children with Autism and Mild Intellectual disabilities (e-Saadhya 2.0):** Autism affects individuals differently, requiring personalized and adaptable learning approaches. With autism impacting about 1 in 100 children globally and limited availability of specialized educators especially in low and middle-income countries there is a critical gap in inclusive education. The rapid shift toward digital learning has further highlighted the need for accessible e-learning solutions. MeitY has initiated e-Saadhya 2.0 project with the objective to facilitate Artificial Intelligence based techno-pedagogical ecosystem for learners with autism associated with mild intellectual disability in both inclusive and special schools. And also to formulate for wider implementation of e-Saadhya an end-to-end framework (screening, assessment, intervention, evaluation and materials used across learning settings) on PAN India basis. This project is being implemented by C-DAC Bengaluru and NIEPID Secunderabad.
- Privacy preserving techniques using Homomorphic encryption of Genomics data:** Fully Homomorphic Encryption (FHE) enables secure computation on encrypted data and is gaining practical relevance as data privacy becomes a policy and security priority, reinforced by the Digital Personal Data Protection Act, 2023. Alongside FHE, privacy-preserving technologies such as Secure Multiparty Computation, Differential Privacy and Trusted Execution Environments are increasingly explored, especially for sensitive domains like genomic data. The strong growth projected for the homomorphic encryption market and related sectors such as genome sequencing underscores the rising need for robust, privacy-preserving data security solutions. Foreseeing these emerging technologies, MeitY has initiated a project with the objective to develop a framework for privacy preservation based on homomorphic encryption for genomics data encryption and analysis. The project is being implemented by a joint consortium of SETS Chennai and C-DAC Pune.
- Blockchain and Machine Learning Powered Unified Video Know Your Customer (KYC) Framework:** Know Your Customer (KYC) is a key requirement for identity verification in the financial sector. A prototype blockchain- and ML-enabled Unified Video KYC Framework has been developed to allow regulated entities (REs) in the financial sector to conduct video-based KYC of their customers. Under the project, a prototype blockchain-based Video-KYC platform has been developed to establish trust among Reporting Entities (REs) for secure and reliable KYC data sharing. The platform includes an audio-visual chatbot to reduce human intervention, machine learning methods to detect face spoofing and verify identity documents, face and voice biometrics for customer identification, etc.
- Visvesvaraya PhD Scheme for Electronics & IT:** MeitY has initiated “Visvesvaraya PhD Scheme for Electronics and IT” with an objective to enhance the number of PhDs in Electronics System Design and Manufacturing (ESDM) and IT/IT Enabled Services (IT/ITES) sectors in the country. Cabinet Committee on Economic Affairs (CCEA) has approved the scheme in 2014. The total estimated cost of the first Phase of the Scheme is Rs. 466 Crores for nine years. The duration of the scheme has been extended up to December 2025. The major achievements of the first phase of the scheme includes completion of 823 Full-time and 189 Part-time PhDs, 19 Full-time and 08 Part-time PhD candidates are at the verge of completion as they have submitted Thesis, 32 Full-time and 59 Part-time PhD candidates are pursuing PhD and will complete PhD soon. Scheme also awarded 158 Young Faculty Research Fellowships. Under the scheme 90 Patents have been filed and 5750 Research Papers have been published by PhD Candidates & YFRF awardees.

Visvesvaraya PhD Scheme for Electronics & IT-Phase II was initiated in September, 2021 with a total budget outlay of Rs. 481.93 crore for a duration of nine years.

The scheme is designed to support:

- a) 1000 Full Time PhD seats in the areas of ESDM & IT/ITES
- b) 225 Post-Doctoral Fellowships.
- c) One time support for 250 Candidates (50 candidates/year) for 6 months Visit to Labs Abroad.
- d) Contingency Research Grant @ Rs. 1.20 Lakh/year per Full Time PhD.
- e) 150 Part Time PhD seats & 50 “Young Faculty Research Fellowships”.
- f) One time award of Rs. 3.0 Lakh for Part Time PhD Candidates after completion of PhD.
- g) YFRF Fellowship & Contingency Grant @ Rs. 20,000/- per month & Rs. 5 Lakh/year respectively up to 5 years.

A total of 1000 full-time & 153 Part-time PhD seats have been allocated to 155 and 112 institutions respectively across the country. On the allocated seats, 774 Full-time & 57 Part-time PhD candidates have been enrolled in 131 and 33 institutions respectively and the enrolment of the remaining seats is in progress. 11 Young Faculty Research Fellowship (YFRF) has been awarded. A total of 125 Post-Doctoral Fellowship (PDF) seats have been allocated to 114 institutions.

## 5.2 Creation of Research Eco-System

### 5.2.1 National Supercomputing Mission (NSM) & High-Performance Computing (HPC)

The National Supercomputing Mission (NSM) was approved by the Cabinet Committee on Economic Affairs (CCEA) in 2015 and is being implemented within the broader framework of Digital India. The Centre for Development of Advanced Computing (C-DAC), under the Ministry of Electronics and Information Technology (MeitY), is responsible for the design, development, and deployment of petascale high-performance computing (HPC) systems.

C-DAC’s efforts encompass the entire HPC ecosystem, including system architecture, components, system software, applications, solutions, and services. The Mission aims to achieve technological self-reliance by progressing in a phased manner—from assembly to manufacturing, and ultimately to design and manufacturing of indigenous supercomputing systems targeted at the exascale ecosystem.

NSM focuses on building and deploying petascale supercomputing capacity across India to strengthen national capabilities in science, engineering, and research. It also contributes to the ‘Skill India’ initiative by fostering expertise in HPC technologies and operations. The overarching objective of NSM is to realize the vision of ‘Atmanirbhar Bharat’ in high-performance computing, empowering national research laboratories, academic institutions, and industries to undertake advanced R&D using indigenous supercomputing infrastructure.

#### 5.2.1.1 HPC Systems Deployed under NSM

C-DAC has successfully deployed 38 supercomputing systems across premier institutions such as the IISc, IITs, national R&D laboratories, and its own centers, providing a total compute capacity of 48 Petaflops (PF). These systems are extensively supporting advanced research initiatives across diverse domains.

During 2025, four(04) new systems were installed at IIT Bombay(3PF), IIT Madras (3PF), IIT Delhi (250 AIPF/8PF) and IIT Patna(838TF). All these systems except IIT Delhi system are built using indigenously designed and manufactured HPC servers “Rudra” and a locally developed HPC system software stack, thereby reinforcing India’s self-reliance in high-performance computing. These systems significantly enhance the computational capabilities available to scientists and researchers across the country.

The PARAM Utkarsh system at C-DAC Bengaluru is supporting initiatives such as Design Linked Incentive (DLI), Chip to Startup (C2S), AI for Cyber Security, and various other industrial research programs. Similarly, PARAM Siddhi at C-DAC Pune is being utilized by startups and research institutions for AI/ML-driven applications in science, engineering, and finance.

The PARAM systems under NSM are being accessed by over 14,000 active researchers, including 1,700+ PhD scholars from 250+ institutions across the country via the National Knowledge Network (NKN). These systems have enabled research in critical areas such as drug discovery, disaster management, climate modeling, astronomy, computational chemistry, material science, aircraft engine design, hypersonic flight, and green energy technologies. To date, researchers have completed over 1.5 crore compute jobs and published more than 1,650 research papers in leading international journals. Additionally, startups and MSMEs are leveraging NSM's HPC and AI infrastructure to accelerate innovation and product development in India.

### 5.2.1.2 Indigenous HPC Technologies under NSM

#### Rudra-I server

C-DAC's indigenously designed Rudra-I server platform is poised to ensure India's self-sufficiency to design, develop and deliver as per country's needs. It has an edge in security conscious environments and businesses. It features Intel Xeon 2nd Generation Cascade Lake processor supporting DDR4 memory.

C-DAC has partnered with EMS partners in India for mass manufacturing of Rudra servers. More than 6000 servers have been manufactured so far. All the NSM Phase-3 systems are based on Rudra -I server. Under transfer of technology agreement, C-DAC has transferred the Rudra Server Design to three industry partners, viz. M/s VVDN, M/s Kaynes technologies and M/s Avalon technologies. These efforts by C-DAC have catalysed the development of entire ecosystem right from design, manufacturing and userbase generation.

#### Rudra-II server

Rudra-II is based on Intel's Fifth generation Xeon Scalable Processor Emerald Rapids. It supports next-gen industry-standard technologies such as PCIe 5.0, HBM & DDR5 memory speeds of up to 5600MT. It is compatible with Open Compute Platform (OCP) 48V DC for Cloud/Data center and HPC market. For cooling it has option of both Liquid (better energy efficiency) and Air cooling.

Rudra-SPX Design validation testing is completed. Production process of the servers has commenced. For production of the servers, C-DAC has signed-up with EMS partners VVDN Technologies and Kaynes Technology. These servers are being used in upgradation and new systems under NSM.

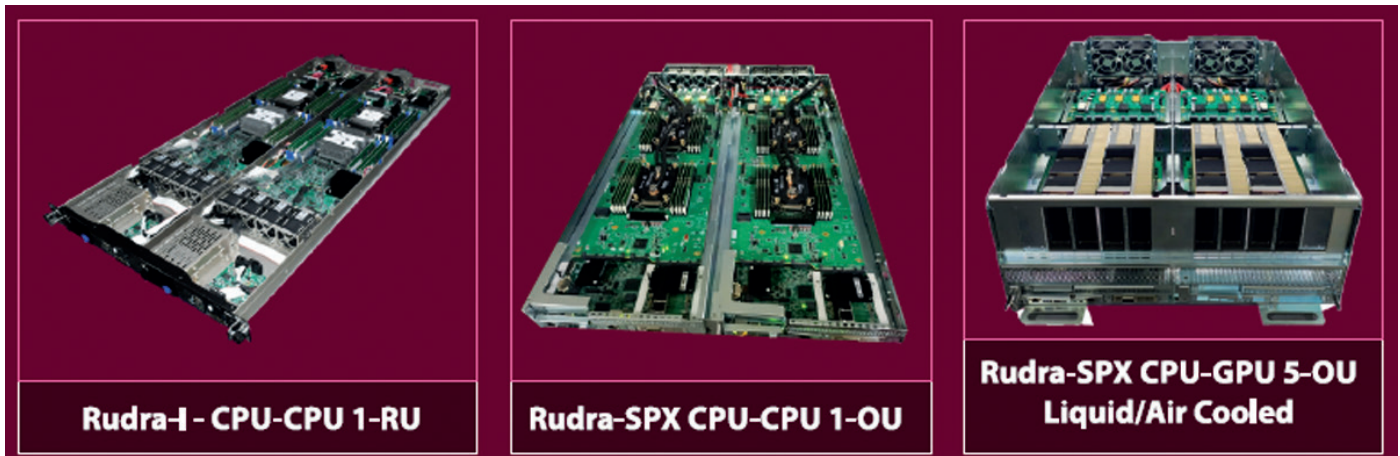

## Rudra-III

Powered by AMD 4th Gen EPYC 9004 ‘Genoa’ processors and 8× AMD Instinct MI300X OAMs, Rudra-GN supports DDR5, PCIe 5.0, and is ORv3 (21”) rack compatible. It is available in two air-cooled variants—20U for HPC and 80U for advanced AI workloads with GPUs.



20U CPU only



80U GPU

## Rudra-GRX-AP server

Rudra-GRX-AP is based on Intel’s sixth generation Xeon Scalable Processor, Granite Rapids (GNR)-AP. It supports next-gen industry-standard technologies such as PCIe 5.0 & DDR5 memory speeds of up to 8800MT. Rudra-GRX-AP Design is completed.

### 5.2.1.3 Trinetra Interconnect

C-DAC’s Trinetra interconnect is aimed at exascale network design without the need for dedicated switching hardware. Under NSM, two variants of Indigenous Trinetra HPC network have been developed:

Trinetra-A is based on PCI-e Gen3 host interface, and 100 Gbps physical link layer. It uses six 100 Gbps links to realize a 3D torus topology. The software stack allows application interface, based on standards to run applications seamlessly. Trinetra-A is deployed in PARAM Rudra (1PF) pilot facility at CDAC, Pune.

Trinetra-B is based on PCI-e Gen3 host interface and 200 Gbps physical link layer technology. The design uses 10 such links to realize ‘Supercluster’ topology. Aggregate throughput from Trinetra-B physical link layer is 2 Terabits/sec, full duplex.

### 5.2.1.4 C-DAC Storage Server Appliance

Based on Rudra 1 motherboard, SSD storage server MK1 is designed to provide the combination of flash performance and capacity. The dual processor provides maximum SSD performance, while the remote DMA feature enhances throughput. A redundant power supply ensures high availability.

Based on Rudra SPX Baseboard, SSD storage server MK2 is developed using Intel Sapphire Rapids processor as storage controller. It has 3U form factor and is configured for both single port working and dual port working of SSDs. E3.S SSDs provide high storage density and 32 slots provide upgradability to enable Petabyte storage in a single server.

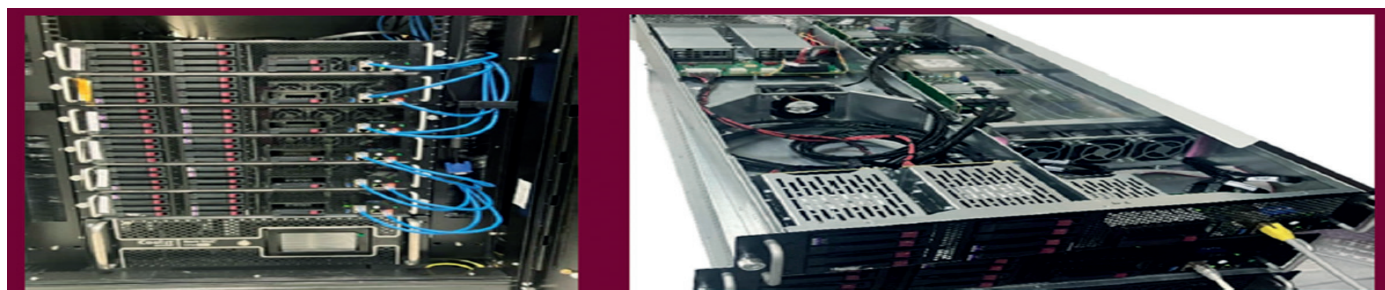

### 5.2.1.5 Development of HPC based applications for national need under NSM

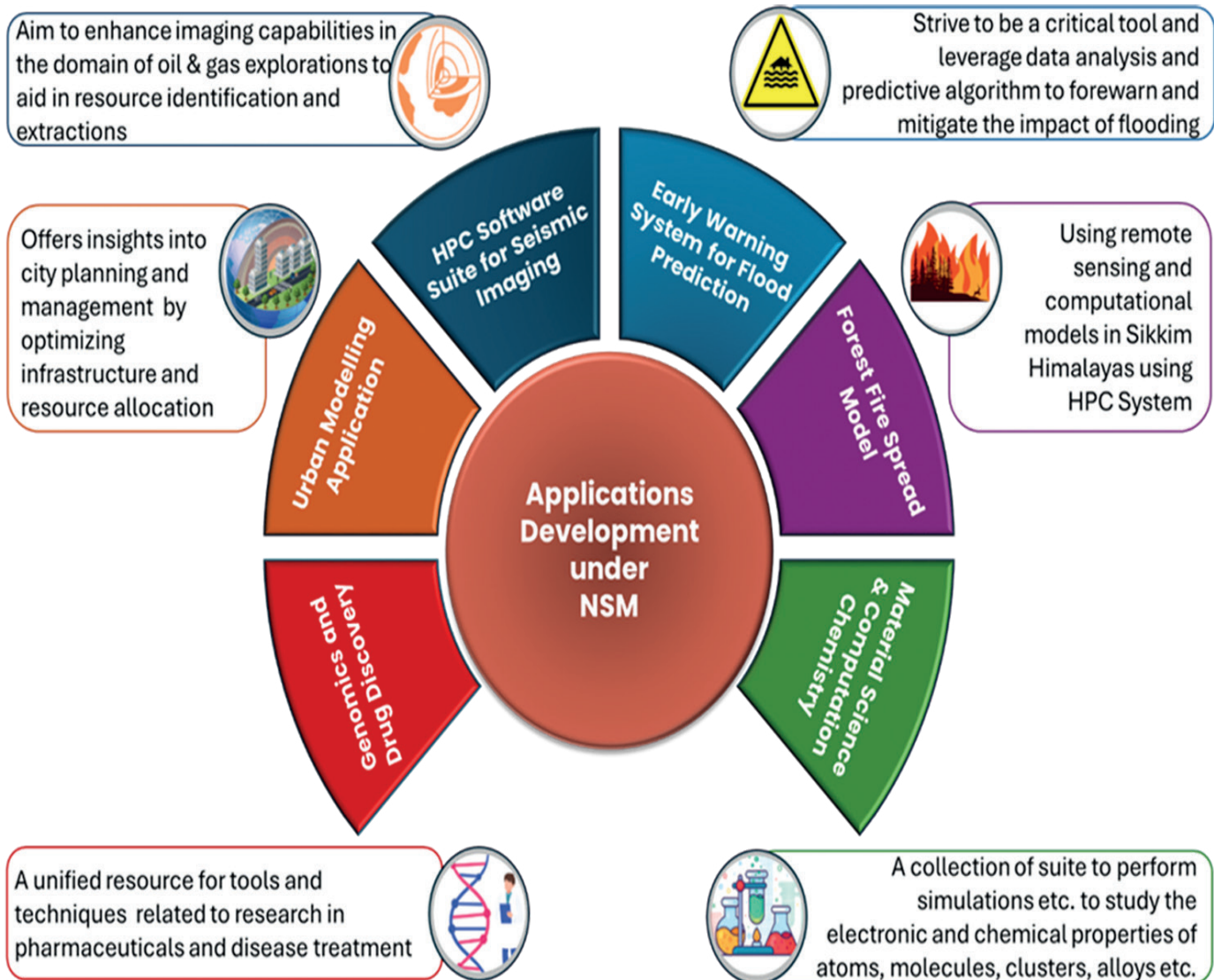

#### Early warning system for flood prediction (EWS-FP) in river basins of India

It leverages data analysis and predictive algorithms to forewarn and mitigate the impact of flooding in the river basins of India by safeguarding communities. Currently, it is used to simulate floods (upto 2 days in advance) in Mahanadi River basin during monsoon. On July 02, 2025, Union Minister of Jal Shakti inaugurated C-FLOOD, a web-based platform that provides two-days advance inundation forecasts up to village level in the form of flood inundation maps and water level predictions. It uses 2-D hydrodynamic modelling to simulate flood scenarios on infrastructure developed under NSM. It marks a transformative step towards strengthening India’s flood management and disaster response framework.

#### A HPC Software Suite for Seismic Imaging to aid Oil & Gas Exploration (SeisRTM)

SeisRTM enables generation of high-resolution 2D and 3D images of complex geological sub-surfaces from seismic datasets. It has been rigorously tested and validated on a wide range of seismic datasets, demonstrating its robustness across diverse exploration scenarios. This Software has been deployed at ONGC and Oil India limited. It has contributed in capacity building, with over 300 students from institutes of national importance trained in its use.

## Simulation Lab and Science Based Decision Support Framework to Address Urban Environment Issues

A fully coupled urban “meteorology, hydrology and air quality” modelling system comprises of Data as a Service (Data Hub), Modelling Platform as a Service (Science Gateway), and a Decision Support System (DSS) for cross-sector end-user decisions. It offers ready-to-use weather, hydrological, and air quality models through automated end-to-end modelling workflows. DSS facilitates easy conversion of scientific data into participatory, multi-stakeholder actions. Through this system C-DAC is providing weather and urban flood forecast to Pimpri Chinchwad Municipal Corporation, Pune Municipal Corporation and Water Resource Dept., Pune. C-DAC is also providing weather forecast to Nashik dist., Kolhapur dist. and Ahmedabad Municipal Corporation. The modelling system has been handed over to MoES for deployment.

## National Platform for Genomics and Drug Discovery

BRAF (Bioinformatics resources and Applications Facility) is provided to start-ups like Elmentoz Research and industries like InSilicoMinds under Platform-as-a-Service (PaaS) and Software-as-a-Service (SaaS). BRAF also serves as the computational backbone for ministerial and departmental research programs, directly accounting for computational usage and provide roadmap which enables long-term sustainability.

Meta-analysis of tuberculosis associated lung-microbiome along with machine learning based classifier has been developed for biomarker identification. Tool for lineage identification of mycobacterium complex and pipeline for pan-genome based analysis of antibiotic resistance has been developed. Computational studies of novel ligand analogs that bind to guanine riboswitches using molecular dynamics simulations have been developed.

Marine metagenomics Information Portal (<https://mmip.niot.res.in/home>) is developed to serve as a one-stop-solution for the storage as well as analysis of Deep Ocean metagenomics data sampled across the Indian sub-continent in collaboration with National Institute of Ocean Technology, Chennai.

### 5.2.1.6 Application Porting, Optimization and Scaling

- Deployed and managed 300+ applications/ libraries/ tools in Molecular dynamics, Material science, Computational chemistry, Weather prediction, CFD, Bioinformatics, AI-ML, and other domains. Conducted acceptance tests on HPC systems at IIT Patna, IIT Bombay, IIT Chennai and C-DAC Bangalore.
- Assisted end users in optimizing their HPC applications - including time-critical workloads - for improved performance, scalability, and resolution. Successfully scaled applications such as LAMMPS and WRF to full CPU capacity (over 2 PF), and AI models to full GPU capacity (approximately 1 PF) on NSM systems at IUAC Delhi and IIT Bombay. Conducted two 3-days and one 1-month hackathon at IIT Guwahati, IIT Kharagpur and IIT Madras respectively to optimize and upscale computational performance of indigenous research applications being developed/ maintained by faculties.
- Explored and benchmarked HPC and AI architectures such as MiPhi, RISC-V based accelerator (Wormhole series by Tenstorrent), SambaNova etc. for performance of applications and frameworks.

### 5.2.1.7 Human Resource Development in HPC

More than 1700 researchers, faculties and students were trained through workshops (conducted online and offline), hackathons, and domain-specific programs, equipping them with skills in HPC, GPU computing, and AI/ML. Faculty development initiatives strengthened research and teaching capabilities, while hackathons and collaborative platforms fostered innovation and community building. These efforts have enhanced India’s HPC workforce, promoted applied research, and advanced the nation’s supercomputing ecosystem. Cumulative 28000 trained since start of the mission.

Currently nine nodal centres located at Indian Institute of Technology (IIT) Kharagpur, Indian Institute of Technology (IIT) Madras, Indian Institute of Technology (IIT) Goa, Indian Institute of Technology (IIT) Palakkad, Walchand College of Engineering Pune, Delhi Technological University Delhi, National Institute of Technology Arunachal Pradesh, IGNTU Amarkantak and Pondicherry University are operational.

C-DAC has established a Centre for HPC Upskilling and Knowledge-sharing (C-HUK) to enable the candidates belonging to SC-ST and Women categories with the knowledge and proficiency in the areas of HPC, AI, Embedded and Cyber Security as part of the NSM. Under C-HUK, 1500+ manpower has been trained.

### 5.2.1.8 International Association

C-DAC is an affiliate member of Accelerated Data Analytics and Computing Institute (ADAC). C-DAC is also an affiliate member of “High Performance Software Foundation (HPSF)”. Under Indo-EU collaboration in High Performance Computing(HPC), GANANA project has been initiated to strengthen research collaboration between India and European Scientific communities focussing on three priority areas Climate Change, Natural Hazards and Bio-informatics.

## 5.2.2 R&D and IP Development

### 5.2.2.1 Convergence, Communications & Broadband Technologies (CC&BT) and Strategic Electronics

The R&D in CC&BT and Strategic Electronics Division of MeitY has been playing a pivotal role as a key enabler of technologies that drive economic growth and development. Its efforts have been focused on advancing India’s digital transformation and strengthening indigenous capabilities in next-generation communication and strategic electronic systems. The previous years have witnessed significant strides in R&D efforts in the domain of cutting-edge Communication and Broadband Technologies, with a clear focus on empowering citizens with pervasive access to digital services across a multitude of use cases and verticals.

The R&D efforts within the CC&BT and Strategic Electronics Division, MeitY aim to achieve several key objectives. These include fostering research and development activities in communications and strategic electronics, with a strong emphasis on collaboration among academic and research institutions, user organizations, industry, and international partners. The Division also strives to promote the commercialization of developed technologies while providing essential technical inputs and support to various ministries, departments, and organizations such as the Department of Telecommunications (DoT), Telecom Regulatory Authority of India (TRAI), Telecom Standards Development Society of India (TSDSI), Department of Science and Technology (DST), Centre for Development of Telematics (C-DOT), Telecom Centres of Excellence (TCOE), Ministry of Information & Broadcasting, Department of Space, and the Bureau of Indian Standards (BIS). These collective efforts contribute significantly to the growth and advancement of India’s digital technology landscape.

To further strengthen the digital ecosystem, R&D initiatives in Convergence, Communications, Broadband Technologies, and Strategic Electronics are directed towards building indigenous capabilities in thrust areas such as Next Generation Networks (NGN) and communication technologies, 5G and beyond, Next-generation mobile technologies, Broadband Wireless Technologies, Green Communications, Quantum Communication, Vehicular Communication, Cyber-Physical Systems, AI-enabled Communication, Big Data Analytics, and the Internet of Things (IoT) for societal applications and disaster management. These initiatives also include Machine-to-Machine (M2M) Communication and Strategic Electronics with applications in both civil and defence domains, along with innovative backhaul communication technologies.

The R&D activities are focused on creating Intellectual Properties (IPs) leading to patents, designing innovative algorithms that contribute to product development, and developing prototypes that provide a strong foundation for advanced technological solutions. The outcomes of these projects are expected to play a vital role in achieving the goals of the Government of India's 'Make in India' and 'Digital India' initiatives.

In the continued endeavor to foster indigenous capabilities in Next Generation Communications and Convergence Technologies, the focus extends across a diverse spectrum of innovations. Key areas include massive multiple-input multiple-output (MIMO) systems, Media Access Control (MAC) and Physical Layer (PHY) SoC (System on a Chip) development for low-power and long-range networks, the creation of a Metro Area Quantum Access Network (MAQAN) with advancements in network management innovation and experimentation, and the deployment of a millimetre-wave (MMW) radiometer for the North-Eastern Region of India. Additionally, strong emphasis is laid on ICT applications in strategic sectors, alongside advancements in Broadband Wireless Access Technologies, Visible Light Communication (VLC), Vehicular Ad-hoc Networks (VANETs), IP-based products and services, and electromagnetic wave applications. The innovation landscape further extends to high-power RF and microwave tubes, Terahertz (THz) wireless systems, and Radar technologies, reflecting a holistic approach towards strengthening India's R&D ecosystem in advanced communication technologies.

The significance of R&D initiatives lies in their potential to propel the nation into the next wave of digital transformation. These efforts underscore an unwavering commitment in advancing the frontiers of technology, promoting innovation, and fostering growth, thereby reinforcing India's position as a leader in the global digital landscape. The mission continues to be firmly rooted in pioneering breakthroughs that enhances the digital ecosystem and bolster the nation's position on the global stage.

**Projects contributing to 6G:** Over the past two decades, MeitY has supported projects including advanced technologies, from 4G to 5G and beyond, including 6G, contributing significantly to global standards and technology prototypes. This played a crucial role in introduction of usage scenario of "Ubiquitous connectivity" for International Mobile Telecommunications (IMT)-2030 (6G) by India in the WP5D meeting held at Geneva in June 2023.

This usage scenario, coupled with the new capability of coverage, enables the development of 6G technologies. Substantial efforts, including the formulation of proposals like Extreme MIMO, 6G Satcom and New Waveforms have been undertaken, and these contributions have been integrated into the 6G Vision document.

The vision of Bharat 6G Mission is to contribute significantly to 6G standards and intellectual property, with the goal of achieving 10% of the Standard Essential Patents (SEPs) in 6G to achieve 6G-self-reliant powered nation.

The following on-going projects align with the above vision:

- 6G End-to-End Communication System
- 6G: Sub-THz Wireless Communication with Intelligent Reflecting Surfaces (IRS)

**6G End-to-End Communication System:** The main aim of the project is to develop fundamental technological innovations and solutions in two important areas, i.e., the maximization of Network coverage & range at high operational frequencies and Development of wireless technology that offers extremely high data rates and extremely low latency with near wireline (fibre) experience.

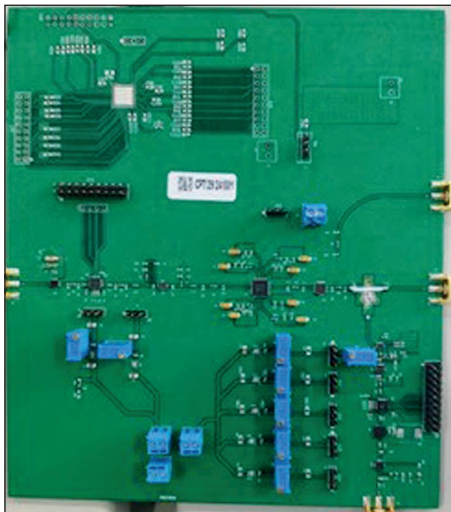

(a) Radio Frequency Front End (RFFE)

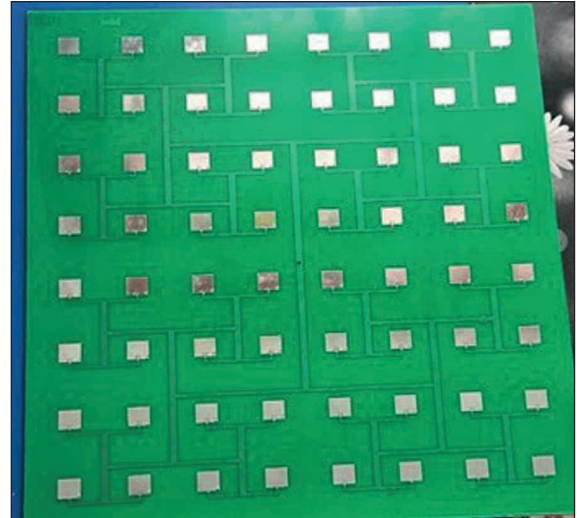

(b) Antenna

The project is aligned with global 6G standards and actively contributes to International Telecommunication Union-Radio Communication Sector (ITU-R) Working Party (WP) 5D and 3<sup>rd</sup> Generation Partnership Projects (3GPP). A 6G New Radio (NR) modem prototype in the 6.425–7.125 GHz band with a novel Orthogonal Time-Frequency Division Multiplexing (OTFDM)-based physical layer integrating 5G NR primitives has been developed to enhance energy efficiency and scalability. The OTFDM Register-Transfer Level (RTL) transmitter/receiver has been implemented and tested on Field Programmable Gate Array (FPGA), and the 6G NR modem integrated with synchronization and data channels. Wireless video transmission using an FPGA-based PHY has been demonstrated, and RF integration at 7 GHz validated key parameters. A 200 MHz bandwidth, 1.2 Gbps throughput, and 125–250  $\mu$ s latency have been achieved. Hardware with 35 dBm TX output, a 64-element antenna array, and efficient FPGA resource utilization has been realized. Contributions to ITU-R WP 5D and 3GPP Radio Access Network (RAN) have been made, including four ITU papers and three 3GPP submissions. Three new patents have been filed, and several publications released. Collaborations with IIT Bhilai, Vignan University, and WiSig Networks have been strengthened, and BEL has signed an NDA for technology transfer. The project remains well-aligned with ITU’s 6G framework, showcasing India’s growing capability in next-generation wireless systems.

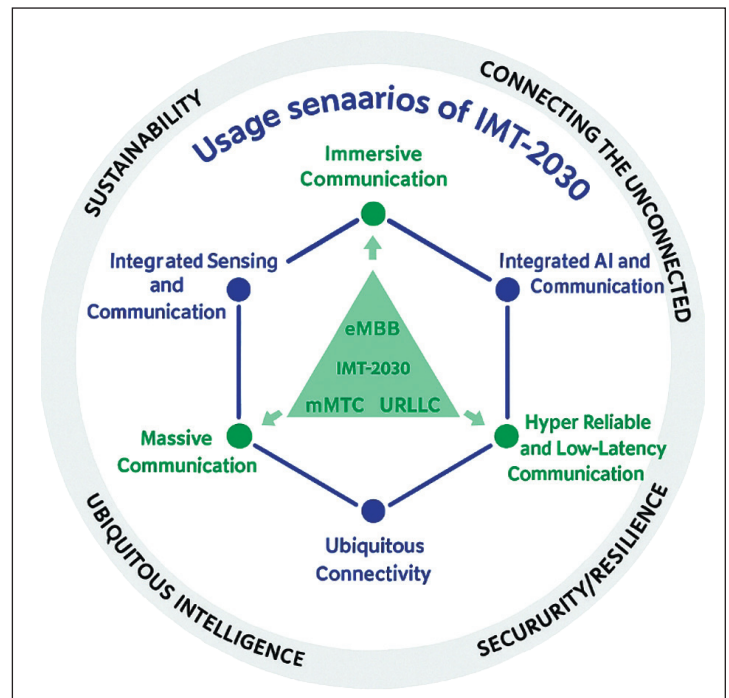

Wheel Diagram-IMT-2030

**6G: Sub-THz Wireless Communication with Intelligent Reflecting Surfaces (IRS):** As part of the collaborative research between Society for Applied Microwave Electronics Engineering and Research (SAMEER) and Indian Institute of Technology Madras (IITM), the objective of the project is to develop and demonstrate a fully functional 6G high speed communication link incorporating various subsystems at 140GHz which includes, sources, multipliers, mixers,

waveguide components like comparators, vector modulators, amplifiers, isolators, power distribution network, intelligent reflecting surfaces and transceivers.

Significant progress has been made in developing D-band and IRS-based communication systems. D-band antenna systems, including plano-convex lens and prime-focus reflector antennas at 140 GHz have been developed, while IRS unit cells at 7 GHz, along with complete hardware and controller have been fabricated and characterized for non-specular reflection and demonstrated at Indian Mobile Congress (IMC) 2025. Key D-band components such as Band Pass Filters (BPFs), Local Oscillator Phased-Locked Loop (LO PLLs), Monolithic Microwave Integrated Circuit (MMIC) housings, and waveguide transitions have been realized, and the first transceiver prototype with Intermediate Frequency (IF) up/down converters has been tested with IIT Madras’s baseband unit. SAMEER also showcased a 145 GHz Line-of-Sight link achieving 6.4 Gbps data transmission using IIT Madras’s baseband signal at IMC 2024 in New Delhi. 6G antennas and components were also demonstrated during the “Digital India Future Labs” event in Delhi organized by MeitY in February 2024. Further, the team has filed 1 patent and several conference publications.



**D-band Transmitter, Antenna and Baseband unit**



**D-band Receiver, Antenna and Baseband unit**



**7 GHz IRS demo at SAMEER Stall at IMC 2025**

**Design of Dynamic MAC and PHY SoC for Low Power and Long Range:** The project has been successfully implemented and tested the IEEE 802.15.4:2020 standard on an ARM M4 processor (nRF52840). Additionally, an out-of-tree module was developed for GNU Radio, supporting ADF7242 and ADF7030 transceivers, and incorporating MAC features based on the IEEE 802.15.4:2020 Time Slotted Channel Hopping (TSCH) Medium Access Control (MAC) standard.

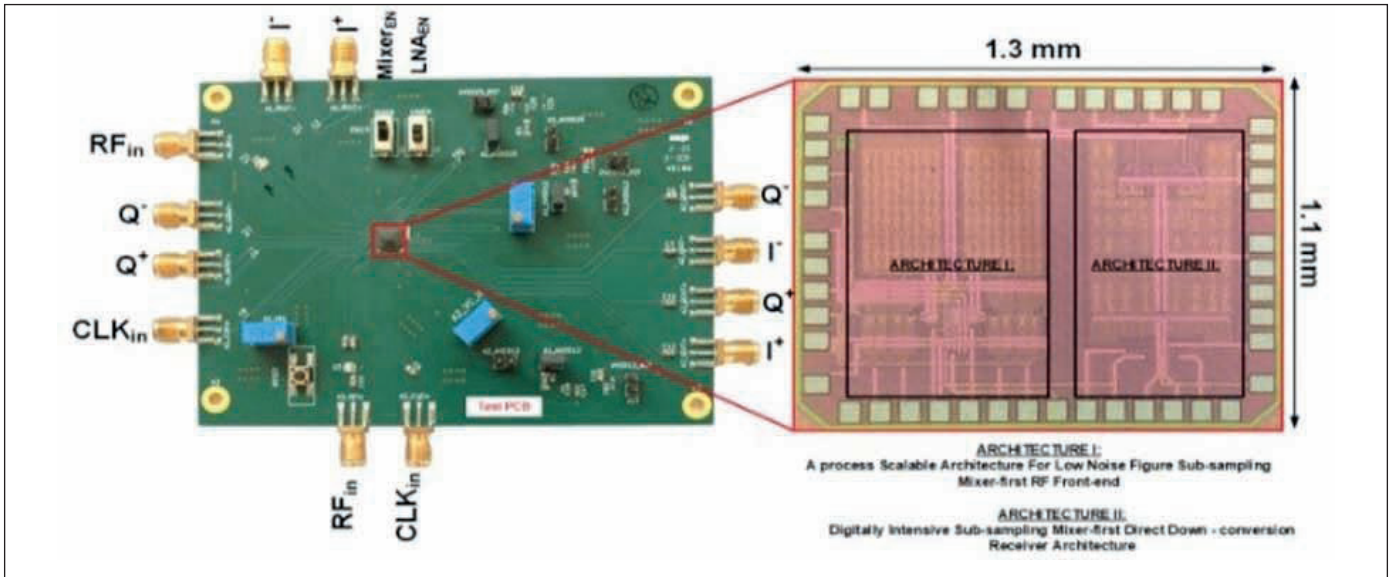

(a) Characterization board of Receiver (b) Full-chip microphotograph of Receiver

The development and testing of a low-power digital baseband operating at 2.4 GHz on FPGA - using the beacon, MAC command, and data frames specified in the IEEE 802.15.4:2020 standard has been completed. Physical testing and Graphic Database System II (GDSII) generation of the developed digital baseband (Phase 1) are also complete, along with the test setup for the same.



Test set-up for Digital Baseband Phase I

Further, tape-out and successful testing of the sub blocks of the RF front end have been conducted. The team has published 2 IEEE transactions, 2 IEEE international conference papers and 2 MDPI journals based on the work done.

**Quantum Key Distribution-based Ultra-Secure and Reliable Optical Networks using Shared Fibre Topology:** The objective of this project is to analyze a physical layer model of a quantum channel integrated with the existing optical networks, demonstrate co-existence of quantum and classical data channels, investigate new disaster aware strategies for providing survivability against natural disasters in optical networks integrated with Quantum Key Distribution (QKD), and strategies for optimal placement of Trusted Repeater Nodes (TRNs) in a metro area network..

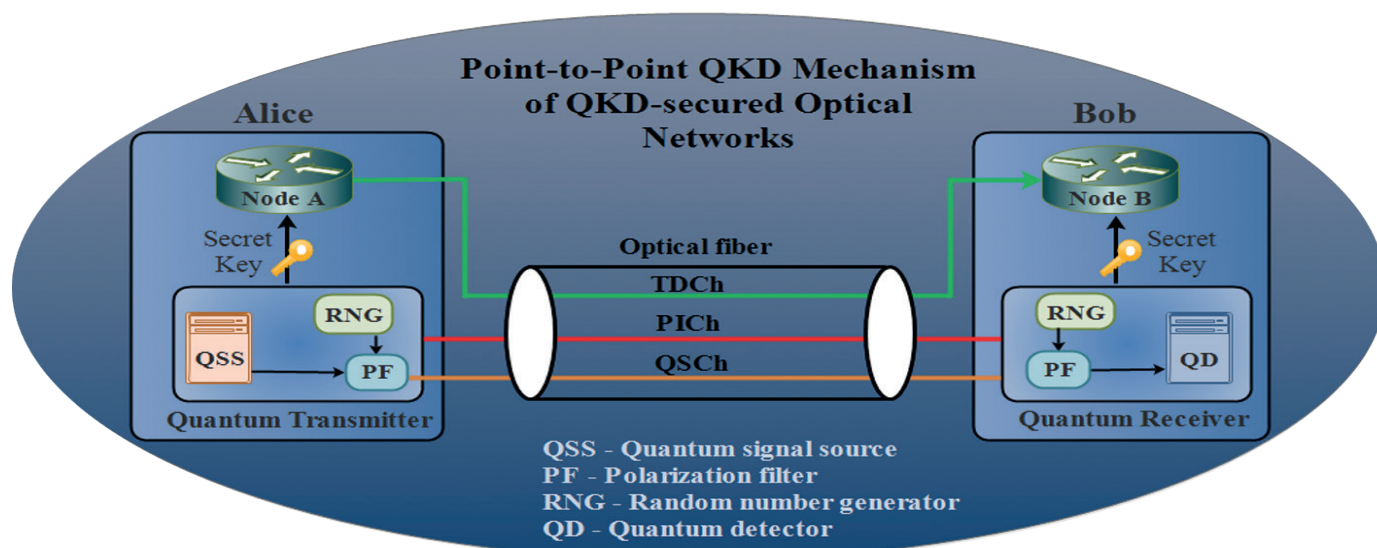

**Architecture of QKD-secured Optical Networks**

The research achieved significant advancements in the practical deployment of QKD over optical fibre networks. A comprehensive quantum–classical noise mitigation model was developed using quantum field theory, Boltzmann kinetics, and cylindrical modal analysis to address phonon-induced decoherence. Lindblad operators for single-mode quantum fields were derived, and a Monte Carlo–based noise cancellation algorithm achieved 80–90% noise reduction, restoring quantum state coherence. Quantum–classical coexistence in Wavelength Division Multiplexing (WDM) fibres was optimized through linear programming of classical channel power, effectively reducing Raman scattering noise and Quantum Bit Error Rate (QBER), leading to improved key rates. Experimental validation was carried out using an Alice–Bob QKD setup, analyzing QBER, Secret Key Rate (SKR), and click rate under real-world conditions, supplemented by IBM Qiskit and VPIphotonics simulations of BB84 and COW protocols to study depolarizing noise, photon loss, and inter-core effects. A quantum-aware, disaster-resilient routing strategy was formulated to ensure secure key distribution during fibre cuts or node failures through proactive rerouting based on QBER, key rate, latency, and risk metrics. Furthermore, a Dynamic Secure Quantum Resource Allocation (D-SQRA) framework was introduced to optimize quantum key and time-slot utilization, reduce blocking probability, and enhance scalability, with simulations on NSFNET and UBN24 topologies confirming superior efficiency over conventional methods.

**Establishment of EMC test facility for testing of strategic electronics systems:** This initiative aims to set up an EMC testing facility in Maharashtra to support the Military, Navy, Air Force, and commercial manufacturers across India’s western zone. With 70% of defence production shifting to indigenous development, India’s limited Military Standard (MIL-STD) testing facilities result in a 6–8 month waiting period for defence manufacturers. This project will boost industry in Maharashtra and the nation due to the presence of defence hubs and the Western Naval Command in the region. SAMEER currently offers limited MIL testing for manufacturers from Pune, Nasik, and Aurangabad, who otherwise travel to southern regions like Chennai for compliance testing due to the absence of an Electromagnetic Compatibility (EMC) facility in the western zone.

The test facility will offer NABL-accredited compliance testing including Shielded Anechoic Chamber (10 m) with fully lined ferrite-tiled and hybrid absorbers meeting the all requirements of CISPR 16-1-4/5, IEC 61000-5-X standard and MIL-STD 461 F for full compliance EMI/ EMC.

The project has progressed with all necessary statutory clearances, including environmental, fire, and Airport Authority approvals, allowing civil activities to commence. The City and Industrial Development Corporation of Maharashtra

(CIDCO) has issued the commencement certificate for the construction of the chamber and laboratories. The Central Public Works Department (CPWD) awarded the contract for civil structure which is being built.

**A Unified IOT Architecture and Development Framework for 5G/6G MMTC Applications:** The objective of this project is to create a customizable 5G/6G generic IoT platform capable of accommodating heterogeneous sensors, with different capabilities, to support many applications with stringent communication requirements having high reliability and high connectivity, address performance to computational architecture, privacy, security, energy harvesting, energy conservation, and many other required aspects in an optimal and robust manner.

**Ongoing MeitY-NSF joint research collaborative projects:**

Ministry of Electronics and Information Technology (MeitY), Government of India and National Science Foundation (NSF) of U.S. signed an Implementation Arrangement (IA) on Research Collaboration. This MeitY – NSF collaborative research opportunity focuses specifically on discoveries and innovations in areas of mutual interest and listed in participating NSF programs that develop new knowledge in all aspects of potential research areas, including the next generation (NextG) advanced intelligent network systems. Technology development/demonstrations may be in terms of development of prototypes, pilot scale demonstrations, field deployment, and other efforts to accelerate technology transfer. Proposing teams of U.S. and India investigators are strongly encouraged to develop appropriate partnerships with test bed providers, local communities, and Industry Partners to ensure that resources and expertise are available for the success of their project.

Following four projects are being implemented by the R&D in CC&BT and Strategic Electronics Division:

- **NeTS: Small: Towards Learning Enabled Sustainable Service Handling in 6G:**

To advance the energy efficiency of future wireless networks, this research proposes the development of a learning-based framework for intelligent resource allocation and control across both the core and radio access segments of 6G systems. By leveraging machine learning techniques, the framework will dynamically adapt to network demands and environmental variations, thereby minimizing energy consumption without compromising performance. Additionally, the study will explore a dynamic learning approach for selecting appropriate security mechanisms based on the time-varying characteristics and historical context of data flows. This adaptive security model aims to optimize protection levels while eliminating redundant processes, thereby contributing to overall energy efficiency and sustainable 6G network operations.

- **A unified Framework for video analytics Optimization and Adaptation:**

This project aims to develop key technologies that enable a unified framework for video analytics pipeline (VAP) development, optimization, and adaptation that streamlines the three major steps in developing a new VAP application.

- **Learning-Assisted Integrated Sensing, Communication and Security for 6G UAV Networks:**

This project aims to develop deep learning-driven outdoor and indoor localisation in Unmanned Aerial Vehicle (UAV) mmWave networks, location-aided UAV mmWave communications, and joint UAV mmWave communication and radar co-design to improve mmWave spectrum utilization, wireless sensing performance, and UAV device security. UAV mmWave networks require deep learning-driven solutions for accurate localization, efficient communication, collaborative sensing, and advanced security to overcome challenges like dynamic environments, signal blockages, and evolving threats in complex multi-UAV scenarios.

- **Experimental Demonstration of Application-Aware, Root-Cause Analysis for Service Disruption: A Cross-Layer Approach:**

This project aims to conduct collaborative research in the broadband wireless communication areas leading to standardization of 5G and beyond technologies by utilizing the expertise available in the country. Further, the research outcomes shall be taken to various standard bodies like 3GPP, ITU, TSDSI, IEEE, and any other standardization fora to contribute to evolving technologies for 5G and beyond.

### 5.2.2.2 Quantum Communication:

Quantum communication applies quantum principles in order to communicate via the transmission of quantum states. It is a field of applied quantum physics, closely related to quantum information processing and quantum teleportation, with the primary application of creating ultra-secure communication networks and quantum cryptography. Quantum communications use photons to transmit quantum bits (qubits) between remote places. This is because photons are very well isolated from perturbations, which translates into long-lived superposition states for photonic qubits. It can propagate with low attenuation (down to 0.2 dB/km at 1.55  $\mu\text{m}$ ) in optical fibres.

- Metro Area Quantum Access Network (MAQAN):** MAQAN has successfully demonstrated India's first operational metropolitan quantum communication network, establishing the feasibility of secure key exchange using QKD protocols over live optical fibre infrastructure. Key milestones include the deployment of a 5-node testbed, successful generation and distribution of quantum keys, integration of Post-Quantum Cryptography, and creation of the DARPAN-Q network controller. The system operated stably for over 50 consecutive days, confirming its reliability.

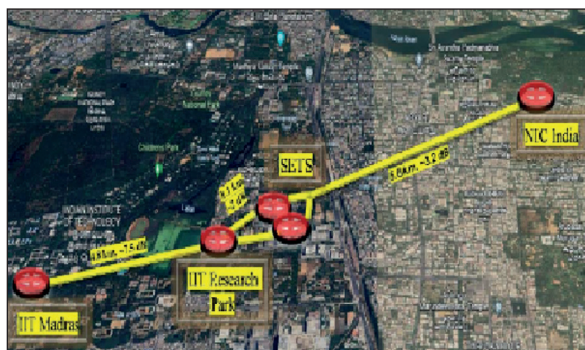

Topology of the MAQAN network

#### MAQAN Links

MAQAN has produced multiple IEEE and arXiv publications. Several government agencies and industries, including BEL, DRDO, and MCTE Mhow, have expressed active interest in technology transfer and further collaboration. Notably, the QKD systems developed under MAQAN have also been tested for their resilience against physical-layer attacks, and a robust security model was established. The project also generated ready-to-commercialize hardware IPs, including quantum communication controllers, FPGA boards, and key distillation engines. These achievements mark a significant leap in India's technological capabilities in secure communications.

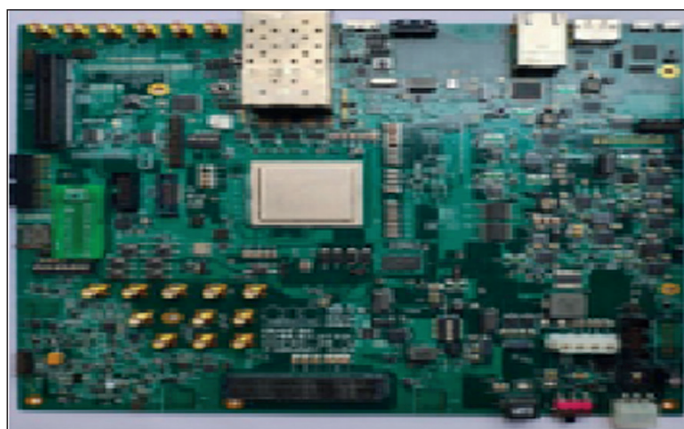

Indigenously developed Quantum Communication Board

- Agile and Ad hoc Free Space based Quantum Communication using Drone (Drone-QC):** MeitY has initiated a project on the Drone based Quantum Communication (D-QC), which is a potential candidate for reconfigurable aerial quantum nodes. The project will achieve indigenous design, development and demonstration of aerial payload including indigenous quantum pointing, acquisition and tracking system for performing quantum communication on a moving platform such as vehicle/drone.

The application domain is free space quantum communication using Drones and Quantum optical relays. It can also serve as the last link for quantum satellites. This will enable us to make a significant contribution to a wide range of technological advancements in India.



Quantum Key Distribution (QKD) using Drone

The project team has successfully demonstrated a free-space prepare-and-measure-based B92 QKD protocol in the laboratory and also developed a drone-to-drone post-quantum cryptography (PQC) link.

**5G+/6G Converged Terrestrial and Satellite IOT (5G+/6G sIoT):** The project has made significant advancements in Satcom and terrestrial communication convergence, achieving key milestones such as developing 3GPP Rel 17 compliant Satcom IoT systems. L-band NB-IoT SoC to support GEO satellites has also been successfully developed which enables a plethora of low-bit rate satellite IoT applications. Furthermore, the project has contributed to the ITU WP 5D IMT-2030 Framework Document by integrating Satcom as a key interworking feature in IMT-2030. The notable achievements include the development of link and system simulators, integration of NB-IoT features, successful  $\pi/2$ -BPSK waveform simulations, and the completion of L2/L3 for 5G NR NTN gNB and UE. Additionally, the team has enhanced its 5G base station (BS) and user equipment (UE) testbeds to support Satcom by designing advanced L1/L2/3 algorithms and protocols and has successfully filed 17 patents focused on advancements in 5G terrestrial and non-terrestrial technologies. These patents cover areas such as waveforms, physical layer (PHY) enhancements, scheduler features, and more.

**Development of MMW Radiometer for NE Region of India for Climate modelling studies for weather changes:** A millimetre wave, ground-based passive radiometer system has been developed in-house for unattended, time-contiguous measurement of tropospheric temperature and humidity profiles in the atmosphere (~ 10 km). Statistical (Machine learning-regressor and neural network-based) and Physical modelling (Optimal estimation, 1D-Var model) based Inverse model was developed for retrieval of temperature and humidity profiles.

A fully functional MMW Radiometer System has been developed, installed, and validated at IMD Guwahati.

**Cognitive Radio for strategic Applications:** This project successfully developed and demonstrated a PoC (Proof of Concept) Cognitive Radio system with real-time spectrum sensing and adaptive communication. An international webinar was conducted with delegates from the Indian Navy, Indian Army, Department of Defence Standardization, DCPW (MHA), ITBP, DRDO (DEAL, CAIR & SAG), NTRO, ISRO, and various industries including L&T, BEL, and ECIL. On the invitation of DNS (IN), the CR System was demonstrated in the Indian Navy pavilion during the Commanders' Conference held at Goa. The stall was visited by the Hon'ble Raksha Mantri, the Chief of the Naval Staff, the Flag Officer Commanding-in-Chief, Western Naval Command, and other dignitaries. The work was highly appreciated by the Indian Navy, being recognized as the "first of its kind in India". The Cognitive Radio terminals developed under this project, with value addition to address custom requirements, are now positioned at the Military College of Telecommunication Engineering (MCTE), Mhow for experimentation and training purposes.

#### **Acoustic Gun Shot Detection System for Strategic Applications:**

This project successfully delivered an advanced, field-deployable acoustic gunfire detection and localization system capable of accurately identifying and locating small-arms fire for strategic and defence applications. The system was developed in three adaptable configurations—Static (networked), Vehicle-mounted, and Soldier-mounted—to support deployment across diverse operational environments. Designed specifically for military and border-security scenarios, the system significantly enhances situational awareness by enabling precise localization of hostile fire and effective monitoring of cross-border firing incidents. As a key outcome, one patent has been filed, and the technology has been successfully transferred to Sagar Defence Engineering Pvt. Ltd. for licensed production.

### **5.3 Translation R&D**

#### **5.3.1 Initiatives under Electronics Components and Material Development (EMDP)**

The Electronics Components & Material Development Programme (EMDP) has been promoting research and development (R&D) since 1986 to nurture indigenous capabilities and strengthen India's electronics manufacturing

ecosystem. The Programme focuses on key areas including electronics materials, components and process technology, photonics, e-waste recycling (circular economy), IoT sensors, and additive manufacturing. EMDP has supported national missions and policies such as the National Policy on Electronics 2019 (NPE 2019) with the objective to encourage industry-led R&D and innovation in all sub-sectors of electronics. The strategy emphasizes a top-down approach to develop self-sustaining R&D centres through industry partnerships. Under this framework, EMDP continues to promote design, engineering, and innovation in advanced materials and components while enabling collaboration between industry and academia. The Programme has focused on developing indigenous product prototypes, IPR generation, technology transfer, and commercialization through start-ups. During the year, six patents were filed by C-MET Hyderabad and C-MET Pune, covering recovery of rare earth elements from e-waste, recycling of photovoltaic materials, polymer-carbon composites for 3D printing, flexible heating pads, RFID tag fabrication, and silicon recovery from IC chips. To date, the EMDP Programme has filed 118 patents directly through MeitY IPR cell and established 16 R&D Centres across India. These efforts have strengthened India's R&D ecosystem by facilitating access to funding, know-how, laboratory infrastructure, and scientific manpower while promoting commercialization and self-sustenance in electronic materials and component technologies. In total EMCD activities has generated 132 patents through the 16 R&D centres.

### **Project Review and Information Management Electronics (PRIME) system for MeitY:**

The Project Review and Information Management Electronics (PRIME) system is MeitY's unified digital platform for end-to-end lifecycle management of all projects across divisions. Developed by C-DAC Noida, PRIME streamlines every stage from proposal submission and appraisal to financial sanction, monitoring, and closure & post closure enhancing transparency, accountability, and efficiency in R&D and non-R&D scheme management. The portal ([www.meityprime.in](http://www.meityprime.in)) provides role-based dashboards and workflows for all stakeholders including Principal Investigators, Group Coordinators, Scientists, Working Group members, PRSG members, and financial and administrative authorities up to the Secretary level. Key modules include proposal management, peer review, project tracking, fund utilization, performance dashboards, and output-outcome monitoring. The system is integrated with e-Office for seamless workflow management and Public Financial Management System (PFMS) with PFMS for real-time financial data synchronization. As of October 2025, PRIME hosts 1,130 projects (including 1,054 ongoing and 76 closed) with 2,785 registered users and 112 scientists on-board. The system now supports scheme-wise and division-wise analytics through dynamic dashboards covering financial trends, milestones, outputs, patents, and publications. Features such as autosave, automatic alerts, mobile-Seva integration, and semantic search on the Secretary dashboard to further improve user experience and decision support. PRIME represents MeitY's shift toward a digitally empowered, data-driven governance framework that links policy, performance, and public accountability. Future enhancements include natural-language-based analytics and AI-enabled insights, reinforcing PRIME as a core component of MeitY's national digital infrastructure for managing India's technology innovation ecosystem.

## **5.3.2 Technology Development & Demonstration for Indian Industries**

### **5.3.2.1 Project on "PUSHPAK- National Mission on Drone Technology-Towards Drone Excellence"**

The Project on PUSHPAK - National Mission on Drone Technology-Towards Drone Excellence has been initiated in a collaborative manner with academia and industries. The project is progressing in development of various sub-systems of the drones to have an indigenous eco-system in this specific area. Basic design work of motors, algorithms, autopilot system have been completed.



Portal Launch by Hon'ble, MoS Shri. Jitin Prasada

### 5.3.2.2 Development of Electronics & IT based Control & Automation solutions for consumer (Toy industries) electronic goods

Under the special budget provision for SC/ST/NER communities, 60 fresh engineering graduates provided with necessary capacity to do research & development in high tech electronics with an application to the toy industry. About 18 toy prototypes have been developed by these interns. To boost the electronic toy sector, for the first time in India, “e-Toycathon 2025” was organized at CDAC-Noida. This online competition attracted 112 teams which delivered three innovative solutions for use by the toy industry.

Keeping in view the success of this project a number of national as well as international toy brands have come forward for collaboration. As a follow up, knowledge sharing with the interns followed by industrial visits were performed.

### 5.3.2.3 Design and development of indigenous, cost-effective Autonomous Tractor, for Indian Farming Conditions and Applications (A-TRACT)

The A-TRACT project envisages the design and development of indigenous, cost-effective technologies for the autonomous navigation of tractors for agricultural applications. The system comprises multiple ECUs in a distributed architecture, interconnected over a CAN FD bus, to enable autonomous manoeuvring in farm fields.

Key subsystems developed includes, Auto Steer subsystem, which automates the tractor steering column; a Precise Positioning System (PPS), consisting of an RTK-based GNSS receiver integrated with an IMU to provide centimetre-level positioning accuracy; and an Autonomous Controller for Tractor System (ACTS), which acts as the master controller responsible for overall vehicle control and hosting the motion-planning and path-planning algorithms.

Motion planning algorithms, kinematic modelling of the tractor, and integrated testing are under development, and field testing of the system on a 24 HP tractor, targeting vineyard applications, is currently in progress.

#### **5.3.2.4 Autonomous Bathymetric Survey Vessel (ABSV) for Advanced Glacier Lake Profiling**

The design and development of an Autonomous Bathymetric Survey Vessel (ABSV) for reservoir and glacial lake profiling has been successfully completed. The prototype was field-tested at two high-altitude glacial lakes—Baspa and Vasuki in Himachal Pradesh—under challenging environmental conditions. This represents a first-of-its-kind indigenous capability in the country and is expected to significantly benefit communities residing downstream of glacial lakes by strengthening disaster-preparedness efforts.

As an important offshoot of the project, a Water Quality Index (WQI) indicator was also developed and validated through field trials. In addition, a Grand Challenge was organized to promote the development of innovative and sustainable indigenous solutions for Glacial Lake Outburst Flood (GLOF) mitigation.

#### **5.3.2.5 The project on “TULIP: TEA HARVESTING UNMANNED ROBOTIC PLATFORM FOR NORTHEAST INDIAN TEA PLANTATION”**

The technical development of sub-systems for vision based identification of two leaves & a bud, Robotic manipulator, cutting and storing of the leaves and related AI based software have been completed. All sub-assemblies have been integrated and extensive testing of the system has been carried out in the model tea factory at Jorhat. For safe and reliable operation, the entire system is powered with an inverter-based power supply. The system field trials are in progress.

#### **5.3.2.6 Joint Call for Proposal under MeitY- NSF (USA) Research Collaboration.**

The U.S. National Science Foundation (NSF) and the Ministry of Electronics and Information Technology (MeitY) of the Government of India have signed an Implementation Arrangement on research cooperation. The Implementation Arrangement provides a framework to encourage collaborations between U.S. and Indian research communities and sets out the principles by which joint activities might be supported. This NSF-MeitY collaborative opportunity focuses on research and technological development in areas of semiconductor, next-generation communication systems, cyber-security, sustainability & green technologies, and intelligent transportation systems. Twelve projects have been awarded jointly with NSF with a combined outlay of nearly \$10 million.

#### **5.3.2.7 National Mission on Power Electronics Technology (Phase-III)**

The National Mission on Power Electronics Technology Phase-III (NaMPET-III) program has been highly successful in strengthening the power electronics technology base in the country by carrying out a multitude of activities like Technology development, deployment, technology transfer, awareness creation & manpower development and strengthening the industry interactions with R&D and academic institutes through collaborative research projects. New Horizon in power electronics technology by Exploratory Research through premier Academic Institutions are carried out especially in Wide Band Gap (WBG) power semiconductor device based power electronics systems, Application R&D in, Smart grid Power Quality Centre Concept (SPQC) is established with Power Quality systems and IOT modules. High voltage power electronic for applications in Medical devices like X-Rays systems are established for first time in the country.

Under the programme User agencies, Industries and startups are participating in the technology development and commercialization through Transfer of Technologies (ToT).

### New technology/ products are developed/deployed in field

- Model EV Charging Station equipped with comprehensive solution for EV public Charging technologies developed under NaMPET, including 7kW & 22kW AC fast charger, 15kW&50kW DC fast Chargers with SiC, Metering, user interfaces, and tariffing along with a mobile app, at C-DAC Trivandrum campus.
- Technology for Planar inductor and Transformer (250kHz, up to 10kV)
- EVIDs Integrated drive for BLDC motor for EV applications - Compact low power drive for BLDC motor integration. Compact Liquid cooled SiC motor drive @30kW. 30kW liquid cooled PMSM motor design prototyping
- First Indigenous Electrical system emulator - Indigenous design of battery emulation @15kW
- First Indigenous MVB controller for TCN based locomotive systems- only 2-3 other solutions worldwide
- AMI pilot deployment operation-SEEMA verified with actual meter interface and simulated large volume meter data (1lakhs)
- High performance Micro PMU with edge computing for Power distribution monitoring- enabling distribution digital twin, HPC power profiling
- Distribution system real-time Trend monitoring with Mico PMU
- VCU for Amrit Bharat - 22+2 coach Push pull configuration in new Amrit Bharat trainset set for trial runs
- First of the kind Microgrid with Interconnected resources
- Power system simulator
- Solar PV powering @LVDC- Microgrid Innovation for Energy Efficiency
- First Indigenous 150kV power supply for X-Rays (Consortium & exploratory projects)
- WBG material-based Magnetometer - First indigenous Hall sensor design & prototyping with WBG material -
- High performance WBG MEMS sensors for torque and vibration
- Wireless charger for LMV
- First Indigenous GaO high voltage diode design prototyping
- Low cost indigenous manufacturing process for high magnetic core power inductor
- WBG Power switch loss estimator

More product/technology launch is being prepared which are in the final stage of technical validations.

In total 20 technologies have been transferred to 31 industries for commercialization and deployments. Field deployment spans defense, railways, smart energy infrastructure, and clean mobility, contributing to import substitution, job creation, MSME empowerment, and national self-reliance. A total of 9 startups have been supported under the programme. The technical activities listed below are qualified for deep tech startup engagements.

- Micro channel based liquid cooling solutions for power electronics
- SiC Device based modular soft switching 3 phase ac to dc power converter for Electroplating application
- BLDC Motor development using readily available ferrite magnet
- Development of customised LoRa based network interface card for Smart Metering

To create the awareness, so far, 25 short-term courses in different areas of power electronics have been conducted at different institutions. 5 International visit realised. NaMPET technology demo is done at power electronics expo. Also presentations are done at various forums during the visit. Products launch by State agencies, CDAC corporate, MeitY

etc. are being arranged. 6 technology functions / ToT programs are conducted with active involvement of MeitY officials, including Secretary, along with members from railway, MoP, MNRE, DST.



### 5.3.2.7.1 Design and Development of Propulsion System for 3 phase Electric Locomotives:

The Ministry of Electronics and IT, in collaboration with the Ministry of Railways, has initiated a national effort to develop an indigenous propulsion system for three-phase electric locomotives, addressing challenges arising from obsolete GTO-based technologies, discontinued ASIC components, and proprietary communication standards. Building on C-DAC Thiruvananthapuram's successful development and deployment of VCU and TCN technologies now operational in over 3,000 locomotives, the initiative proposes the design and development of Traction Converter technology, engineering of the Auxiliary Converter, and transfer of the VCU technology for Train Control and Management System (TCMS). The project will be implemented through a consortium of C-DAC, CLW, and Indian Railways-identified industries with joint financial support from MeitY, the Ministry of Railways, and industry partners. This programme aims to strengthen domestic capability, reduce dependence on foreign suppliers, and advance the vision of 'Aatmanirbhar Bharat' and 'Design and Make in India'. The expected outcome is a fully indigenous propulsion system including traction converter, auxiliary converter and VCU with TCMS, ready for adoption by Indian Railways and further commercialization through qualified industry partners. This will be the highest (5000kW) power electronics converter technology development for propulsion in the country.

### 5.3.2.7.2 Development of Planar Magnetic Components for MHz Applications and customization for Electronics & Radar Development Establishment (LRDE's)(DRDO) Active Phase Array Radar (APAR)

The Ministry of Electronics and IT, under the National Mission on Power Electronics Technology (NaMPET), has initiated an advanced R&D project on the development of Planar Magnetic components for MHz Applications in Active Phased Array Radar (APAR) systems. The project aims to establish indigenous capability in high-frequency, high-power-density planar magnetics to address critical requirements of APAR systems developed by LRDE, DRDO. The initiative focuses on designing, fabricating, and testing compact planar inductors and transformers operating in 1 MHz range, with lower form factors, to meet the demanding size, efficiency, and thermal constraints of modern radar platforms. The project aims to develop planar magnetics for both ground-based and airborne APAR systems, along with a dedicated magnetics test bench and encapsulation techniques for rugged operation. The outcome is expected to reduce import dependence, enable customization for strategic applications, and support domestic production of high-power-density converters, benefitting defense, aerospace, radar manufacturers, and high-frequency power electronics industries.

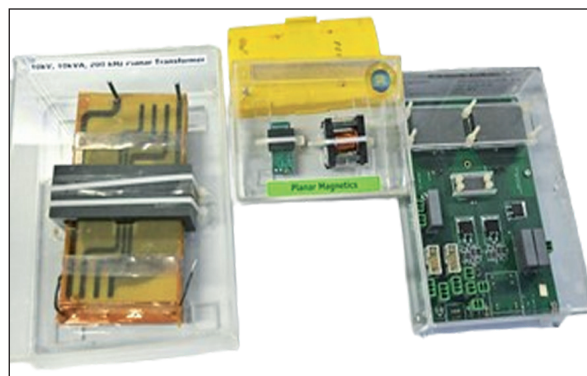

Planer Magnetics based sub-systems

### 5.3.2.7.3 Mission-Critical Power Electronic Systems for the AKASH launch vehicle in the Indian Defense Sector

During the Operation Sindoor, the Akash surface-to-air missile system, along with other air defense systems like the MR-SAM and S-400, played a crucial role in neutralizing aerial threats, showcasing India's "layered defense grid". The indigenously developed Akash system demonstrated its reliability in intercepting multiple drones and missiles, engaging four targets simultaneously at a range of 25-45 km. The operation also highlighted India's growing self-reliance in defense technology and its ability to counter asymmetric warfare.

Position control of the launch vehicle is critical to achieving mission accuracy. Despite numerous technical challenges, the Power Electronics Group at CDAC-Trivandrum successfully developed the required technology and transferred it to Tata Advanced Systems Limited (TASL) for production. Through this contribution, CDAC has played a key role in advancing national self-reliance in high-end defense electronics.



2x 5.6kW PMSM drive

### 5.3.2.8 AgriEnIcs: National Programme on Electronics and ICT Applications in Agriculture and Environment

The Ministry of Electronics and IT has initiated a national-level programme to reform the agriculture and environment sectors with the interventions of IoT, ICT, machine learning and robotics technology. The objective of this umbrella programme is to encompass the industry, users, academia, R&D institutes working in the allied domains of the thematic areas to develop user friendly and market viable technology. C-DAC Kolkata is executing this program in collaboration with multiple collaborators and Industry/start-ups. Research and development in the domains of agriculture, livestock management, and environment were focused on the development of products and the developed products are validated and certified for commercialization through industries. The AgriEnIcs programme has successfully lead to the capacity building, innovation, technology transfer and industry engagement. The technologies such as Electronics based Dairy Solution (Go-P & MAST-D), e-Quality for Agriproduces (Grain-Ex, RIGE-Sense), air quality monitoring system (AI-AQMS, brand name AirPravah), has been commercialized to the industries in the presence of Secretary, MeitY. After the transfer of technology for the Air Quality Monitoring Device (AI-AQMS) various units has been sold in the markets and is currently available on the GeM portal. The technologies like Smart poultry management and Chick gender identifier (GEMS) and Robotic apple harvester device are ready for commercialization.

### 5.3.2.8.1 Agri-Excellence: National Programme on Application of Electronics and ICT in Himalayan Region Crop Management

The Ministry of Electronics and IT has initiated a national-level programme for Himalayan Region crop management, leveraging automation, robotics, IoT, and ICT technologies. The objective of the programme is to pursue national-level R&D, product and solution development, and commercialization for identified crops of saffron, walnut, and apple for the Himalayan Region, in collaboration with academia, R&D institutions, and industry partners. Sher-e-Kashmir University of Agricultural Sciences and Technology (SKUAST), Kashmir, is executing this programme in partnership with multiple collaborators and industry/start-ups. The Agri-Excellence programme has been launched to develop automation technologies in agriculture and support farmers through smart cultivation and e-marketing solutions. Currently, technologies under the programme are being developed for application in identified crops cultivation, post-processing and e-marketing.

### 5.3.2.8.2 e-GUNA: Sensory assessment for quality of fermented foods from North-Eastern

The Ministry of Electronics and IT has supported the project which is being implemented by Centre for Development of Advanced Computing (C-DAC), Kolkata, the Institute of Bioresources and Sustainable Development (IBSD), Imphal, the National Institute of Technology (NIT), Nagaland, and the Indian Institute of Technology (IIT), Hyderabad. This initiative aims to develop and deploy a point-of-analysis device for the detection of bacterial pathogens and toxins in fermented food products. Currently, the project has generated 03 technologies such as CG-STAT system, an electrochemical sensing platform for the detection of cyanogenic glycosides in fermented foods which has been developed, field trialed, deployed, and IP protected through an Indian patent application and copyright. IIT Hyderabad has pioneered the development of FP-SENS, a food pathogen sensor that can simultaneously detect a range of bacterial pathogens including *Staphylococcus aureus*, *Bacillus cereus*, *Escherichia coli*, *Listeria monocytogenes*, *Clostridium botulinum*, and *Proteus mirabilis* that integrates seamlessly with mobile phones. IBSD Imphal and NIT Nagaland have collaboratively worked on developing a software platform for the analysis of Foodpatho chips. The technologies are now ready and underway commercialization.

### 5.3.2.9 Development of Electric Vehicles (EVs) Sub System (EVSS)

The Ministry of Electronics & IT (MeitY) has initiated a program on “Development of Electric Vehicles (EVs) Sub System (EVSS-I) with broad objective to indigenously develop the Electric Vehicle sub- systems in the areas of Electric motor, controller, converters Chargers, BMS, etc., for 2-Wheeler, 3-Wheeler/e-rickshaw, and economy 4 Wheeler. The EV sub-systems development is being taken up in consortium mode consisting of academic institutes/ R&D organization for design and development, industry to commercialize it and vehicle manufacturers to use the developed product in the manufacturing. Technology of high-efficiency PMSM motor and controller for e-rickshaw, BLDC Motor Controller for low- to medium-power e-vehicle applications, and a BLDC motor with a smart Vehicle Control Unit for e-rickshaw have been developed, tested, and transferred to various industries for production and commercialization. 2 kW DC portable EV charger was launched by Secretary MeitY, Shri S. Krishnan with the setup and inauguration of the Model EV Charging Station (MCS) at Technology Park, Thiruvananthapuram. The Mobile EV DC Fast Charger and 3 kW DC-DC Converter were launched by Hon’ble MoS MeitY, with transfer of technologies to industries. Out of the technologies undertaken in EVSS, EoIs for all the 10 completed technologies have been published to enable technology transfer and facilitate engagement with potential industry partners for commercialization.

Additionally, to support EV Battery technology developments, a Resource facility for EV Battery packaging including electro chemical workstation and thermal management in battery pack is established at C-DAC, Thiruvananthapuram Development of Motor/Controller/Charger/Converter Technologies under EoI for EVSS.

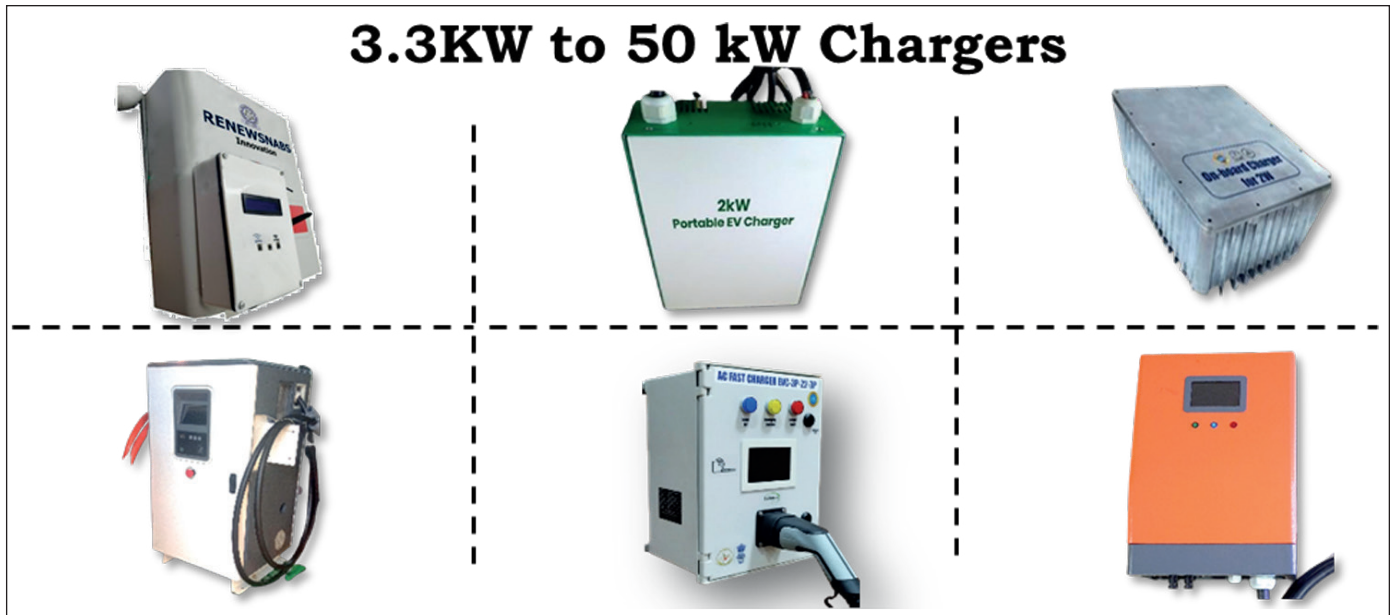

#### 5.3.2.9.1 MeitY-MHI Electric Vehicle Sub System Programme

The Ministry of Electronics and IT in collaboration with Ministry of Heavy Industries (MHI) has announced MeitY-MHI Joint Call for Proposal for “Development of Electric Vehicle Sub-System” in the presence of Secretary, MeitY. Based on the need of vehicles on the road, development of technologies for the 2-Wheeler, 3-Wheeler/e-rickshaw, and economy 4 Wheeler were mainly taken up in the first phase of EVSS programme. Now to enlarge the base of technology development in the areas of motor/motor controller, converters, BMS, Chargers etc., for all segment of electric vehicle including heavy vehicles and enhance the chances of commercialization, a unique model has been introduced, involving Product Development Agencies (PDAs) like T-Works, iCreate, MOTION, NATRAX, and GARC. These agencies will support academic institutions in technology development by offering their expertise and state-of-the-art infrastructure. Under this programme, MeitY will provide financial support for development of the technologies, while MHI will take forward the technologies for standardization, testing and dissemination to user agencies and industry partners. The expected outcome of the technology/product has to be cost-effective, quality competitive and ready for commercialization.



**Announcement of MeitY-MHI Joint Call for Proposals for EVSS in the presence of Shri S. Krishnan, Secretary, MeitY, and Dr. Hanif Qureshi, Additional Secretary, MHI**

The first call for proposal was successfully completed and 19 proposals are approved for R&D and deployment category by Academic Institutions, CDAC, ARAI, Industries and startups.

### 5.3.2.10 Digitally Connected Tribal Colonies Project

The Ministry of Electronics and Information Technology (MeitY), Government of India, and the Scheduled Tribes Development Department (STDD), Government of Kerala funded the Digitally connected tribal colonies project under the aegis of which CDAC Thiruvananthapuram, in collaboration with the Regional Cancer Centre (RCC), Thiruvananthapuram, has successfully implemented a comprehensive programme for the prevention and control of non-communicable diseases (NCDs) among marginalized tribal communities in Wayanad district, Kerala.

As part of the programme the following has been successfully established

- A disease-screening hub, equipped with a suite of indigenously developed medical devices by C-DAC Thiruvananthapuram for smear preparation, processing, staining, and digital imaging.
- Software which helps in digital workflow of screening process which includes door to door survey, management of camps using mobile app, AI assisted digital pathology systems enabling remote analysis and reporting by Pathologists across the nation.
- Dashboard software for centralized monitoring & coordination, traceability, statistics & reporting.
- Mobile Apps for screening of high-risk candidates, implementation of camps workflow and reporting to medical officers
- Employment of eligible candidates from the local community and training for NCD screening and sample processing
- Conduct of NCD screening camps with the support of PHCs/CHCs and LSG depts.
- Reports and follow-up with medical officers and ASHA workers

This programme has so far yielded the following results

- CDSCO license for the devices and software used for the programmes.
- Door to door health survey & Awareness covering 90000 family members.
- 69 NCD Screening programmes covering 7500 examinations including Pap test, oral brush biopsy and breast clinical examinations.
- More than 200 precancerous early conditions detected using the deployed system and follow-ups.

A disease-screening hub setup at Wayanad equipped with complete set of indigenously developed medical devices for sample processing, smear preparation, processing, staining, digital imaging and reporting. The NCD screening initiative was recognized by UN by awarding the UNITF award in 2024 for NCD screening using assistive devices.

As part of this initiative 46 societal classrooms in Wayanad has been enhanced with video conferencing facilities, a studio room has been set up with connectivity to all the societal classrooms, software and programs were deployed in all the classrooms, programs were devised to ensure better attendance of students in societal classrooms. The impact of this program is phenomenal as is evident from the attendance increase in societal classrooms from less than 100 to more than 900 students.

#### 5.3.2.11 Robotic Surgery for Total Knee Arthroplasty

The Ministry of Electronics and Information Technology (MeitY), Government of India, has initiated Robotic Surgery for Total Knee Arthroplasty. Health technology innovation centre at IIT Chennai and CDAC Thiruvananthapuram has successfully implemented the Robotic Navigation software and the same has been successfully demonstrated to various surgeons of the country who are experts in conducting knee replacement surgery using robotics.

The indigenously developed surgery planning system along with the navigational modules will now be subjected to clinical trails following which it will be transferred to industry for clinical deployment.

Work is in progress to integrate the navigational robotic system to the entire set up which will enable robots to perform the surgery under the supervision of Doctors.

#### 5.3.2.12 Development of Indigenized Digital Dentistry Solutions

Development of Indigenized Digital Dentistry Solutions, programme funded by MeitY, targets development of indigenized and cost-effective solutions for Digital Dentistry which can streamline clinical workflow of dental procedures and benefit patients and clinicians alike. The project targets to develop the entire ecosystem for Digital Dentistry which being (1) Cone Beam CT Scanner (b) Extra Oral Scanner (c) Intra Oral Scanner and (d) Virtual Dental Treatment Planning software. The project activities have been initiated with C-DAC, Thiruvananthapuram as the nodal implementing agency collaborating with Centre for Dental Education & Research, AIIMS, New Delhi and Indian Institute of Technology - Madras.

Prototype of CBCT scanner, Extra Oral Scanner has been completed along with Dental Implant Planning software. CDSCO Test license has also been obtained for developed components. To optimize workflow a suite of AI Services are also being developed which can greatly reduce planning and diagnostic effort has also been integrated to the developed systems.

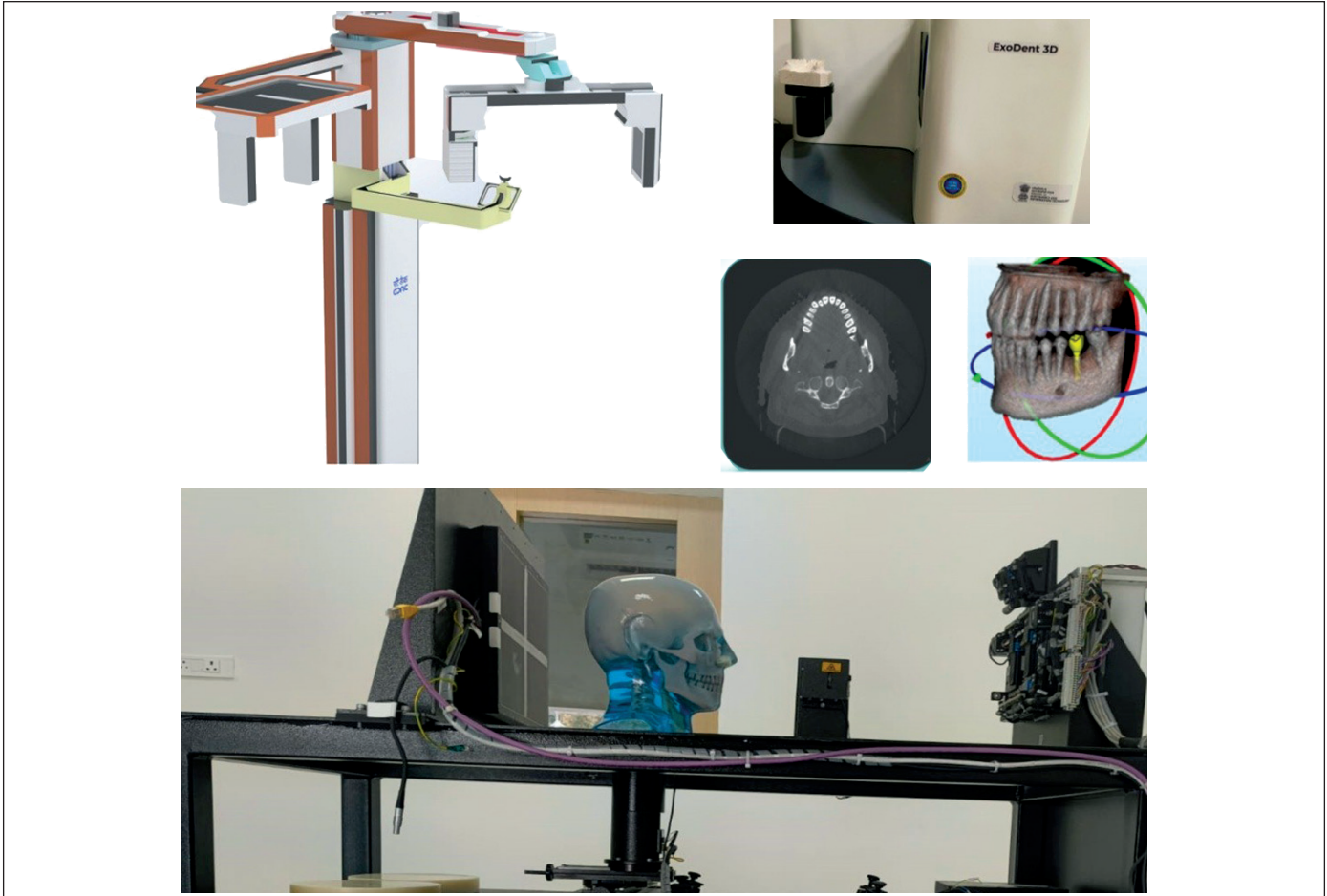

Clockwise from Top Left. CBCT final system design, Extra Oral Scanner Prototype, CBCT Reconstructed Image, Implant Planning system , CBCT Workbench

### 5.3.3 Initiatives under Microelectronics and Nanotechnology areas

#### 5.3.3.1 Some of the technologies developed/are being developed indigenously under the R&D projects initiated in Microelectronics area are:

##### 5.3.3.1.1 Chips to Start-up (C2S) Programme

Refer Chapter 7.

##### 5.3.3.1.2 Design Linked Incentive (DLI) Scheme

Government of India has approved the 'Modified Programme for Semiconductors and Display Fab Ecosystem' with an outlay of ₹76,000 crore in order to catalyse the semiconductor & display ecosystem in the country. The Design Linked Incentive (DLI) Scheme has been approved as part of it with an outlay of Rs. 1000 Crore to offset the disabilities in the domestic semiconductor chip design industry as well as move up in value-chain and strengthen the semiconductor chip design ecosystem in the country. The DLI Scheme offers financial incentives & design infrastructure support to domestic companies, start-ups and MSMEs across various stages of development & deployment of semiconductor chips. Under DLI Scheme

- 94 companies have been approved for access to state-of-the-art Electronic Design Automation (EDA) tools.

- 24 projects have been sanctioned for financial support to design chips for various applications such as surveillance camera, radar for drone detection, energy meter, microprocessor IPs, networking applications, and more.
- Out of these, twelve (12) companies have successfully completed prototype tape-outs at various semiconductor foundries and raised venture capital (VC) funding for scaling up their design prototypes for commercialization.

### Microprocessor Development Programme:

As part of the Microprocessor Development Programme, C-DAC has earlier successfully completed the design and development of the VEGA series of microprocessors including India's first indigenous 64-bit multi-core RISC-V based Superscalar Out-of-Order Processor. The VEGA series comprise of 32/64-bit Single/Dual/Quad Core superscalar Out-of-Order high performance processor cores based on RISC-V Instruction Set Architecture. Currently six variants of these indigenous Processors are available, that has state-of-the-art architecture and performance at par with other commercially available processors and is targeted for various strategic/industrial/commercial applications. Several SoC chips integrating the VEGA Processor with various System, Communication and Peripheral IPs have also been successfully taped out earlier including the 'THEJAS32' a 32-bit VEGA Single Core Processor based SoC and the 'THEJAS64' a 64-bit VEGA Single Core Processor based SoC. The 'THEJAS64' SoC that was fabricated at the Indian foundry SCL, Chandigarh and is the first fully indigenous 64-bit VEGA based System-on-Chip (SoC) designed for embedded applications.



C-DAC has recently successfully developed India's first fully homegrown Dual Core Processor based SoC 'DHRUV64'. The 1GHz 64-bit 'DHRUV64' System-on-Chip (SoC) is the third chip based on the VEGA series of indigenous RISC-V processors designed for robust and compute-intensive embedded applications. The SoC integrates the power of the VEGA AS2161 16-stage O-o-O Dual Core high performance Processor with various communication interfaces and peripherals in a FCBGA package. The processor supports single and double precision floating point instructions and an MMU suitable for Linux based applications.

Designed, developed and validated entirely in India, DHRUV64 supports embedded and IoT applications in the areas of Industrial automation, Networking, Medical Electronics and Consumer Electronics.

As part of proliferation of the indigenous VEGA processor, more than 800 members of academia and industry trained on VEGA processors as part of 13 workshops conducted. VEGA processor and peripherals licensed to M/s IndieSemiC, Ahmedabad, IIT Indore and IIIT, Pune.

### 5.3.3.2 Some of the technologies developed / are being developed indigenously under the R&D projects initiated in Nanotechnology area are :

#### 5.3.3.2.1 Products/prototypes/technologies developed and MoU signed/collaboration under the Nanotechnology Initiatives Division:

- **Health Technologies: Making Diagnostics Accessible and Affordable**

MeitY-supported innovations are transforming healthcare by making diagnostics faster, cheaper, and more accessible—even in remote areas.

### **MOBILAB: Smart Portable Blood Testing Device**

A portable device that can test 25 vital health parameters (like liver, kidney, diabetes, and anaemia) in just 30 minutes has been developed and certified by ISO 13485, ISO 9001, IEC, EMI, EMC and CDSCO. The device has been recognized by ICMR by its best innovation award. The product is already listed on the GeM portal and manufacturing plant has been setup in Greater Noida.

### **E-Eyes: Non-Invasive Heavy Metal Detector**

E-Eye based optical sensors have been developed for the detection of harmful metals like arsenic, iron, chromium, and fluoride in water and biological samples without drawing any blood. The sensor has been tested on around 100 spiked real samples and shown comparable results. The field trials will be taken up by the industry partners.

### **Smart phone enabled paper strip-based Haemoglobin detection system**

An ultra-low-cost blood hemoglobin estimation device has been developed using a paper strip, offering results comparable to lab tests without the need for trained personnel. Device comprises a paper strip, a Smartphone, and a 3D printed enclosure fitted with LED. It can estimate hemoglobin concentration from a low range of 3.5 g/dL to a high range of 19 g/dL with sensitivity 0.1 g/dL. It provides faster and more precise quantitative results. The technology has been transferred to 5 industry partners for commercialization.

### **Ultra-Fast Point-of-Care RT-PCR for detection of Sickle Cell Anaemia**

A portable handheld ultra-fast Point-of-Care RT-PCR device has been developed and optimized for early and accurate detection of sickle cell disease and trait. Hospitals and research centers are being approached for field trials and sample sourcing.

### **Allergen Detection Camera**

A handheld camera-based device that detects allergens like egg, peanuts, milk and wheat. After getting the ethical clearance, the field trails are being conducted at Institute of Child Health, Kolkata.

- **Brain-Inspired Computing Platform**

CMOS System on Chip (SoC) has been developed using molecular films for the AI hardware that can mimics how the human brain stores and processes data and memristors. A step toward indigenous neuromorphic chips. On this technology, 7 national patents have been filed. 4 articles have been published in high impact factor (I.F.) international journals out of which 3 are published in highly reputed journals namely: Nature (I.F. 69.5), Nature Electronics (I.F.40.9) and Nature Materials (I.F. 47.65).

- **Civil Infrastructure and Industrial Safety Sensors**

Optical fibre-based sensors have been developed and tested in laboratory to monitor structures, improve safety, and enable futuristic technologies. The list includes:

- **Displacement Sensors:** To measure movement in bridges and buildings. Some prototypes have been provided to Aimil Ltd. for the field trial.
- **Tilt Sensors:** To monitor structural angles and pantograph movement. Laboratory testing is completed and final packaging is being carried out.
- **Vibration Sensors:** To measure vibration in buildings and bridges. These have been installed at Kolkata Metro and NTPC Korba plant. Field trials have been done in collaboration with Aimil Ltd.
- **Strain Sensors:** Deployed at Paro-chu River bridge for real-time stress monitoring.
- **Hydrogen Sensor:** Detects hydrogen leaks that critical for industrial safety and clean energy systems.
- **Zincometer & Flawguard:** For the real-time monitoring of zinc coating on wires. The technology has been transferred and new orders received from Tarapur Plant II.

### 5.3.3.2.2 Startups in different domains have been incubated during the reporting period:

Two startups namely, Spectrofab Pvt. Ltd & Gunsutra Pvt. Ltd. have been incubated under the MeitY funded “Nanoelectronics Network for Research and Applications (NNetRA)” at IIT Delhi.

### 5.3.3.2.3 Publications

74 research articles have been published in National and International journals in the reported duration. Out of these, few are published in highly reputed journals namely: Nature (I.F. 69.5), Nature Electronics (I.F.40.9) and Nature Materials (I.F. 47.65).

### 5.3.3.2.4 National/International Patent

28 patents have been filed, and 5 patents have been granted in the reported duration.

### 5.3.3.2.5 Societal Outreach activities

- **Nanoelectronics Roadshow**

The MeitY, in partnership with IISc Bengaluru, IIT Bombay, IIT Madras, IIT Delhi, IIT Kharagpur, and IIT Guwahati, successfully hosted the national level event “Nano Electronics Roadshow” at IISc Bengaluru. The roadshow was inaugurated by Secretary, MeitY, along with Additional Secretary, MeitY. This marked a significant milestone in India’s vision of a self-reliant semiconductor ecosystem. The roadshow showcased over 100 intellectual properties (IPs), more than 50 groundbreaking technologies, and the innovation of over 35 promising startups all backed by six state-of-the-art nanoelectronics centres across the country. Taking forward Hon’ble Prime Minister Shri Narendra Modi’s clarion call for Aatmanirbhar Bharat, the event highlighted India’s technological leadership in the electronics and semiconductor domain, driven by cutting-edge research and innovation at Nano centers established by the MeitY within the IISc and IIT ecosystem. The roadshow served as a platform for over 700 industry leaders, policymakers, and academics to explore areas of collaboration around strategies for strengthening India’s nanoelectronics ecosystem.



- **Brainstorming session on neuromorphic computing at IIT Delhi on 16<sup>th</sup> April 2025**

A national level brainstorming session was held at IIT Delhi, bringing together over 40 experts from premier institutions to chart a strategic roadmap for indigenous development in neuromorphic technologies. The aim of

the session was framing the collaborative vision in the Neuromorphic Computing sector. Discussions focused on processor design, circuit and material innovation, and system integration. Participants included industry leaders Aheesa™ Digital Innovations and CYRAN AI Solutions, and top academic institutions such as IISc Bangalore, IITs (Madras, Patna, BHU, Gandhinagar, Bombay, Delhi, Hyderabad, Jodhpur, Roorkee, Kanpur), JNCASR, IISER Thiruvananthapuram, and Digital University Kerala.

## 5.4 Centre of Excellence

### 5.4.1 Nanotechnology Centres

Nanotechnology Initiatives Division at MeitY has established several Centre of Excellence in Nanotechnology to take the basic R&D outcomes to the prototype and then to manufacture Nano devices, subsystems, systems for the social benefits.

#### Centre of innovation & a Manufacturing Eco-System for Sensors (CIMES) in Industrial IoT

The Centre of innovation & Manufacturing Eco-System for Sensors (CIMES) in Industrial IoT is being established at CSIR-CGCRI, Kolkata to enable a start-up and innovation ecosystem in the country as a solution provider in the optical fibre-based sensors and instrumentation for industrial IoT. The main objective of the centre is to create a knowledge and resource centre for Indian industries and place India in the global market of optical fibre-based sensors and instrumentation in the domain of geotechnical and structural health monitoring and industrial process control instrumentation

#### Magnetic Sensor Innovation for Diverse Sectors

A dedicated facility for the upgradation and commercialization of magneto-resistive sensors leveraging GMR and TMR technologies, is being established at CSIR-NAL for 6-inch wafer scale. The initiative aims to develop cost-effective, industry-grade sensor solutions for the automotive sector, with a focus on technology transfer to industrial partners. Key efforts are directed toward customizing magnetic sensor products such as ABS speed sensors, current sensors, and angle sensors, tailored to specific industry requirements

#### Gas sensor testing and calibration facility

A national state-of-the-art gas sensor testing and calibration facility is being set up at CSIR-NPL for gases such as H<sub>2</sub>, O<sub>2</sub>, CO, CO<sub>2</sub>, NO<sub>x</sub>, SO<sub>x</sub>, H<sub>2</sub>S, N<sub>2</sub>H<sub>4</sub>, NH<sub>3</sub>, Volatile Organic compounds, etc. The sensor facility test will evaluate the device's performance (5 sensors in each chamber). The gas concentration will be covered in the range from ppb to ppm levels as required for the specific gas. The analysis will provide accurate & precise information on the sensitivity, selectivity, stability, response time, acceleration test, error, temperature profile, etc., of test gas sensing devices. This initiative is expected to contribute significantly to environmental safety and industrial automation by providing reliable gas sensing solutions tailored to diverse sectors.

### 5.4.2 Centre of Excellence on E-Waste Management

- **Circular Economy in Electronic Sector**

The Electronics System Design and Manufacturing (ESDM) sector is the heartbeat of India's digital economy—powering innovation, connectivity, and productivity across every domain. Electronic and Electrical Equipments (EEE) manufacturing is dependent on high material consumption with various rare earth elements. Rate of extraction of these abiotic resources for EEE manufacturing is significantly higher than the rate of their formation in nature. Due to growing demand of electronics sector, India became the third largest consumer of raw materials produced globally, and with the current economic trend, estimated to consume nearly 15 billion tonnes of raw material by 2030.

Moreover, this rapid growth of Electronic sector also brought an escalating challenge: E-waste generation. According to the UN Global E-waste Monitor 2022, India is the third-largest generator of e-waste globally, producing 4.17 million metric tonnes annually, with an 18% annual growth rate. This creates mounting pressure on ESDM ecosystems, critical materials supply chain, environmental issues etc.

Electronics waste (e-waste) is a global challenge and India is also facing the problem due to rapid use and fast disposal of the electronic gadgets, as also, lack of safe disposal facilities. The growing e-waste also depicts higher consumption of electronic and electrical products, which is obvious for economic development and aspirational behaviour.

Lack of proper recycling facility and infrastructure and dominance of informal sector have complicated the situation in India. Nearly 95% e-waste is recycled in informal sector with lack adequate skill-sets, knowledgebase and equipment. Moreover, lack of awareness about the ill-effect of the unscientific recycling, environmental safeguarded process possesses significant health hazards.

The dominance of informal sector could not be restrained and formal sector is facing stiff competition from them in terms of economy and acute shortage of input feedstock. Manufacturers are also facing the challenge to dispose of collected e-waste due to shortage of end to end recycling facility.

To sustain this momentum responsibly, India is steering toward a Circular Economy (CE) model—replacing the linear “take–make–dispose” pattern with a regenerative approach of “reduce–reuse–repair–refurbish–recycle–remanufacture.”

The Ministry of Electronics and Information Technology (MeitY), Govt. of India has undertaken several flagship initiatives under its Circular Economy Action Plan to mainstream circularity with in the electronics ecosystem. These initiatives span R&D and technology innovation, RoHS compliance and testing facility, skill and capacity development, awareness, informal sector formalization, and advanced recycling infrastructure.

- **R&D and Technology Development**

India’s first Centre of Excellence (CoE) on E-waste Management has been established at C-MET, Hyderabad (an autonomous body under MeitY), as hub for R&D, start-up incubation, skilling and technology transfer. Its focus areas include developing cost-effective recycling technologies for extraction of critical minerals from spent PCBs, Lithium-ion batteries, uorescent lamp phosphors, Rare Earth Permanent Magnets, and Solar Panels.

Over 25 industries have already adopted these technologies. A pilot-scale facility for PCB recycling (1 Tonne/day) has been set up at the CoE. Moreover, to build India’s capability in rare earth minerals, a pilot project for NdFeB magnet production from spent magnets by recovering rare earth elements like neodymium and praseodymium has been initiated.

- **Skilling and Capacity Building for a Green Workforce**

Recognizing that sustainable electronics require skilled human capital, MeitY has established e-waste dismantling and segregation facilities at NIELIT Gangtok, Panjab University Chandigarh and C-MET Hyderabad. Standardized training curricula aligned with the National Skills Qualification Framework (NSQF) and supported by a Learning Management System (LMS) are building a national talent pool for responsible recycling.

More than 3000 professionals have been trained across the country in environmentally sound dismantling, segregation, and e-waste handling. In parallel, an AICTE approved M.Tech program on E-waste Management at IIT Hyderabad—now in its third cohort—is nurturing future innovators and entrepreneurs in the green electronics domain.

- **Formalizing the Informal Sector**

India’s informal e-waste ecosystem—comprising over 20 lakh workers—plays an essential role in material recovery but often operates without environmental or safety safeguards. To transform this segment, MeitY launched the

project on “Informal Sector Capacity Building and Upgradation with Formation of Recycling Clusters” under the CDP-MSME scheme of Ministry of MSME. This program is being implemented jointly by C-MET Hyderabad, CIPET Bhubaneswar and NML Jamshedpur, the project aims to create 30 e-waste recycling clusters across India, engage and upskill 15,000 informal workers, and facilitate their integration into the formal recycling ecosystem. This approach ensures that India’s transition to circularity is inclusive, combining economic empowerment with environmental protection.

- **RoHS compliance and testing facility:**

The Restriction of Hazardous Substances (RoHS) directive currently restricts the use of ten hazardous substances in EEE products: lead, cadmium, mercury, hexavalent chromium, polybrominated biphenyls (PBB) and polybrominated diphenyl ethers (PBDE), bis (2-ethylhexyl) phthalate (DEHP), butyl benzyl phthalate (BBP), dibutyl phthalate (DBP) and diisobutyl phthalate (DIBP). RoHS regulations apply to all the manufacturers and distributors of electronic and electrical equipment, and compliance is mandatory for any sellable product sold in the EU. The Restriction of Hazardous Substances (RoHS) testing facility at C-MET, Hyderabad laboratory is a self-sustainable world class NABL accredited testing facility under RoHS directive for the evaluation of electronic and related products to help the Electrical Electronics Equipment (EEE) industries. This RoHS testing facility has been established under the aegis of Ministry of Electronics & IT (MeitY), Government of India. This facility follows all Standard Operating Procedures (SOPs) as per IEC 62321-3-5:2023 standard. RoHS analysis of variety of products are being carried out using these advanced characterization facilities. The test facility is accredited as per ISO 17025:2017 standard by National Accreditation Board for Testing & Calibration Laboratories (NABL), Department of Science & Technology, Government of India, in the field of chemical analysis of electronic materials (polymers, metals, etc.).

### 5.4.3 CoE on Rechargeable Battery Technology (Pre-cell)

Lithium-ion batteries are emerging as the preferred energy storage solution for consumer electronics, electric mobility, renewable power, and e-governance applications such as VVPAT machines. India currently has a strong lead-acid battery industry but remains largely dependent on imports for lithium-ion cells, with domestic industries focusing mainly on battery pack assembly. To address this gap, MeitY is supporting R&D for cost-effective, end-to-end indigenous technologies suited to Indian conditions, aimed at reducing import dependence and promoting SME participation.

In this direction, MeitY has established the Centre of Excellence (CoE) on Rechargeable Battery Technology (Pre-Cell) at C-MET, Pune for self-sustainable R&D, scale-up, and transfer of indigenous lithium-ion and sodium-ion battery technologies to Indian industries, enabling the creation of a domestic battery-cell manufacturing ecosystem. The centre has trained 90 specialized manpower and produced 20 research publications. It has developed three proof-of-concept technologies leading to field deployment and filed nine IPRs in advanced rechargeable battery materials and processes. The centre has engaged with 10 start-ups for collaborative R&D. A total revenue of ₹100 lakh has been generated towards self-sustenance, reflecting strong translational and commercialization potential.

No.	Technology available for ToT	Description
1	Development of Lithium cobalt oxide as cathode material for Li-ion batteries	LiCoO <sub>2</sub> a cathode which is commercially used in Li-ion batteries.
2	Development of Lithium titanium oxide as anode material for Li-ion batteries	Lithium titanium oxide (LTO-Li <sub>4</sub> Ti <sub>5</sub> O <sub>12</sub> ) exhibiting cubic spinel structure can easily accommodate 4 lithium ions (Theoretical capacity – 175 mAh g <sup>-1</sup> ) at higher plateau potential above 1.4 V, is the safe choice as anode material in Li-ion batteries for EV applications

No.	Technology available for ToT	Description
3	Development of Lithium (Nickel Manganese Cobalt) oxide as cathode material for Li-ion batteries.	The NMC-111 offers better temperature and cycling stability when compared to the LCO.
4	Development of Sodium Vanadium Phosphate (NVP) as cathode material for Na-ion batteries	Sodium vanadium phosphate ( $\text{Na}_3\text{V}_2(\text{PO}_4)_3$ -NVP) a NASICON-type material with exceptionally high ionic conductivity is acknowledged as a potential cathode for high-performance

#### 5.4.4 Graphene Aurora

A graphene-based RF printable antenna prototype was developed using graphene ink, and a TRL-3 hemoglobin biosensor using rGO-modified electrodes demonstrated reproducible performance with potential for clinical applications. Fire-resistant graphene-reinforced coatings were developed for EV battery housings and were found to meet AIS-156, IS 17855:2022, and UL-94 V-0 safety standards. A pilot supply of graphene-based structural coatings was completed for Aero Alloys. In addition, graphene manufacturing and scale-up partnerships were established with Adnano, Capattery, Terracarb, Graphenera, and masterbatch manufacturers including Bhagyashree and Indradhanush.

Internship programs were launched to support translational research and commercialization, with engineering and science interns contributing to electronics circuit design and graphene technology development.

#### 5.4.5 Centre for Programmable Photonic Integrated Circuit and Systems (CPPICS):

A programmable Photonic Integrated Circuit (PIC) is next-generation reconfigurable photonic processor platform with wide-ranging applications in quantum computing, quantum communication, 5G/6G communications, IoT, radar, and avionics. To build indigenous capability in this domain, MeitY has established the Centre for Programmable Photonic Integrated Circuits and Systems (CPPICS) at IIT Madras, under the Centre of Excellence (CoE) initiative, in collaboration with industry partners. The Centre focuses on R&D, design, and fabrication of programmable photonic integrated circuits and systems using CMOS-compatible silicon photonics technology. It has successfully developed several technologies, including a Fiber Optic Array Attachment Tool for PIC packaging, RF filters and microwave photonic oscillators (operating up to 60 GHz), and an indigenously built Quantum Random Number Generator (QRNG) based on silicon photonics. The QRNG has been successfully transferred to industry through a ₹1 crore technology licensing agreement with Indrarka Quantum Technologies Pvt. Ltd., marking a major milestone in India’s photonic innovation ecosystem. Since inception, CPPICS has trained 71 specialized manpower, produced 28 research publications, demonstrated two proof-of-concept technologies, filed six IPRs, transferred one technology to industry, and engaged two industries and one start-up, generating ₹55.07 lakh in self-sustenance revenue. The Centre aims to achieve self-reliance in photonic processor design and packaging within five years through commercialization, industry collaboration, and skill development, positioning India as a key player in silicon photonics and programmable photonic computing.

#### 5.4.6 National Centre for Quantum Accelerator Chip using Lithium Niobate (NCQAC)

The National Centre for Quantum Accelerator Chip (NCQAC) has been established at IIT Kharagpur in partnership with C-MET Pune and M/s New Age Instruments & Materials, Gurugram. The Centre aims to develop indigenous photonic integrated circuit (PIC) technology using Lithium Niobate on Insulator (LNOI) for ambient-temperature quantum accelerator chips (QACs) with applications across education, R&D, financial modeling, and high-performance computing. NCQAC focuses on the complete LNOI technology value chain from wafer growth and thin-film deposition at C-MET Pune to design, fabrication, and packaging of photonic quantum chips at IIT Kharagpur. Major achievements

include successful design and fabrication of rib and strip-loaded waveguides, 3-dB couplers, and periodically poled LNOI (PPLN) structures for nonlinear optics. State-of-the-art facilities are being created, including ISO-6/7/8 cleanrooms, PIC design and lithography labs, and quantum application laboratories. A total of 18 trained manpower and multiple academic collaborations (University of Paris-Saclay, University of Sorbonne, University of Paderborn, TCG Crest) have been established.

The project is progressing toward fabrication of full LNOI-based Quantum Accelerator Chips by FY 2026, supported by industrial participation for packaging and commercialization, positioning India as a key player in global photonic-quantum computing technologies.

#### 5.4.7 National Strategy for Additive Manufacturing (NSAM)

Additive Manufacturing (AM), is a key enabler of Industry 4.0 and 5.0, integrating digital design, simulation, and fabrication to create complex components layer by layer. AM enhances productivity, flexibility, and sustainability, enabling rapid prototyping, mass customization, and distributed production. It supports UN Sustainable Development Goals (SDGs) through material efficiency, reduced emissions, and localized manufacturing. For India, AM presents a transformative opportunity to strengthen indigenous manufacturing, reduce imports, and advance toward a USD 1.45 trillion manufacturing economy by 2030, positioning the nation as a global hub for advanced and sustainable manufacturing. In this direction, India launched National Strategy for Additive Manufacturing (NSAM) in 2022 for development and deployment of AM technologies in India aspiring to achieve \$1 billion Indian AM market. The program is being implemented through seven development and deployment centres and R&D projects.

##### 5.4.7.1 National Centre on Additive Manufacturing (NCAM)

- National Centre for Additive Manufacturing (NCAM) is a company registered under section 8(1) of the Companies Act 2013. The NCAM is established by the Ministry of Electronics and Information Technology (MeitY), Government of India and ITE&C Department, Government of Telangana has been established in Hyderabad, Telangana, in partnership with industry.
- The NCAM is established as an independent agency to build a comprehensive ecosystem of additive manufacturing in the country by enabling the adoption in the industry, prototyping new products and focusing on indigenization, access to state-of-the-art infrastructure, enabling research and development of standards, enabling key foreign players to establish their manufacturing units and new product development, and promoting skill development activities to generate quality manpower.
- The vision of NCAM is “To create and enable a sustainable ecosystem for product innovation in India with emphasis on research, design, development, and testing through collaborative efforts between academia, industry and government using the disruptive technology of Additive Manufacturing”. NCAM acts as the central agency to promote, foster, and drive the adoption of additive manufacturing technology in India to make the country AtmaNirbhar in the sector.
- The Centre has engaged 20 start-ups with a focus on generating IPR. NCAM has organized workshops, seminars, and conferences for delegates across India, cumulatively benefiting over 69,000 professionals. A total of 25 Faculty Development Programs were conducted across various states including Jammu & Kashmir, Punjab, Uttar Pradesh, Maharashtra, Karnataka, Tamil Nadu, Andhra Pradesh, and Telangana. Additionally, NCAM has conducted 34 Additive Expert Talks and collaborated with industry partners to organize seven international events in Delhi, Mumbai, Warangal, and Hyderabad. These events exhibited new technology and audience gained knowledge on the subject.



#### 5.4.7.2 National Additive Manufacturing Centre West (NAMC-W)

- Under the AM initiative, the project “Establishment of National Additive Manufacturing Centre West (NAMCW) at Ganpat University, Gujarat – India” had been initiated in collaboration with the State Government of Gujarat and industry stakeholders, seeks to augment AM adoption across six western states, aligning with NSAM’s aspirations.
- NAMCW endeavours to create a self-sustainable facility for product development and training, promote the commercialization of AM products, foster skilled manpower, and instil future-ready skills among students through Science, Technology, Environmental, Advanced Manufacturing, or STEAM learning. By nurturing the domestic AM ecosystem through awareness programs, NAMCW aims to bolster inclusive growth and empower the AM manufacturing industry, spanning large enterprises, MSMEs, and startups, in line with the vision of ‘Atmanirbhar Bharat’. To date, the centre has supported three startups and trained over 3,500 individuals through executive programs, certification courses, and B.Tech/M.Tech awareness programs.

#### 5.4.7.3 CoE on Additive Manufacturing- Optoelectronics Sector

- Additive Manufacturing (AM) is disruptive set of technologies which are bringing fundamental change in how manufacturing is carried out in many sectors due to its ability for mass customization. AM is enabler for digital manufacturing which has capability in producing products directly from design data by adding layers of material to obtain the final shape with minimal waste, supporting Industry 4.0.
- Ministry of Electronics and Information Technology (MeitY) has initiated a Centre of Excellence on Additive Manufacturing at Centre for Materials for Electronics Technology (C-MET), Pune in collaboration with Central Institute of Plastics Engineering & Technology (CIPET), Bhubaneswar.
- The objectives of the centre are to support Indian Additive Manufacturing Eco-system through focused and coordinated research, design and development in collaboration with 3 participating industries. The centre is expected to achieve self-sustenance and focus on developing indigenous materials and machine technologies for electronics manufacturing sector.
- In current phase of the project, 36 product/PoCs (material, machine, 3D printed products) have been developed. The project is also bringing opportunities for Indian companies to develop their own AM material and machine technologies for global market at much reduced R&D cost for any sector (not limited to electronics) such as aerospace, medical, automotive etc. The centre is also training manpower to support growth of AM economy in India.

#### 5.4.7.4 Centre for Promotion of Additive Manufacturing: Optical Computing Chips (OCC)

- Optical computational chips and photonic devices finds application in various fields of technologies such as communication, computation, healthcare, automation, sensor and defense. However, although they have shown plethora of applications, their industrial viability is mainly limited by their fabrication process which involves presence of foundries, numerous process- equipments and steps.

- In recent years, Additive Manufacturing (AM) processes are bringing fundamental change in how manufacturing is carried out in many sectors due to its ability for scalable, cost effective and sustainable fabrication process. AM is an enabler for digital manufacturing which has capability in producing products directly from design data by adding layers of material to obtain the final shape with minimal wastage. 3D printing in optical computing chip for global market
- The Ministry of Electronics and Information Technology (MeitY) has initiated a centre on Additive Manufacturing based Cost-Effective Optical Computing Chips at Indian Institute of Science, Bangalore (IISc) in collaboration with Centre for Materials for Electronics Technology (C-MET), Pune.
- The objective of the centre is to design and fabricate global state of the art 3D printer to achieve sub-micron resolution, indigenous materials for printing and to design & fabricate optical devices for computation. The centre is expected to achieve self-sustenance and focus on developing indigenous materials and machine technologies for photonics manufacturing sector.
- The centre is also bringing opportunities for Indian companies to develop their own AM material and machine technologies for global market at much reduced R&D cost for any sector (not limited to photonics) such as aerospace, medical, automotive etc. The centre has designed and developed 3 materials, 2 machine and 1 software. Additionally, training has been provided to 65 personnel.

#### 5.4.7.5 CoE on Additive Manufacturing: Medical Device Sector

- Ministry of Electronics and Information Technology (MeitY) has initiated a Centre of Excellence on Additive Manufacturing at Andhra Pradesh MedTech Zone, Vishakapatnam, Andhra Pradesh which will support Medical Device Sector.
- The vision of the centre is to make COE at AMTZ a hub (common facility for local AM industry which will offset disabilities for competing with global peers) for medical device innovation in India by nurturing various medical device start-ups through Additive Manufacturing (AM) technology.
- Through this centre sustainable long-term ecosystem will be provided to start-ups and industries which will enable medical device innovation in India; build skill-sets in the AM industry, in particular AM in the medical industry to achieve competitive advantages in the global market; promote creation of Indian IPR & facilitate IPR filing activity and offer industry, academia, global linkages to provide market access to the incubated products.
- The CoE has achieved several milestones both in skill development and technology development. Over 2400 manpower were trained in 3D printing, Medical Device Design, Prototyping and Testing in CoE AM - MDS. CoE is successful in establishing production of materials and products which earlier were under import dependency. The CoE developed 4 materials, 5 machines, 2 softwares and 9 AM products. The CoE also created capacities to deliver the highest quality small metal components with outstanding levels of chemistry control, strength, and density across a wide range of alloys.

#### 5.4.7.6 Centre for Promotion of Additive Manufacturing - Agri & Food Processing (CPAM – A & FP)

- The Center for Additive Manufacturing (CPAM), established under the Additive Manufacturing (AM) initiative of MeitY at the Centre for Development of Advanced Computing, Kolkata, pioneers a groundbreaking concept of Agri-factories.
- These facilities integrate agri-produce lines with value-added agri-product lines, ensuring control over quality, quantity, and costs. Through this innovative approach, dependency on open agri-produce markets diminishes. CPAM's mission encompasses enhancing time-to-market, market resilience, and establishing product-independent manufacturing lines for value-added agri-products, introducing AM to the sector for the first time

globally. Additionally, AM will streamline production by creating supply chain components such as agri-produce line modules and agri-photonics components, thereby reducing costs.

- Collaborating with institutions like CSIR - Central Food Technological Research Institute, Mysuru, Central Manufacturing Technology Institute, Bengaluru, and IIM Calcutta Innovation Park, CPAM aims to indigenously develop the Agri-Factory concept and AM machinery and materials.
- This initiative aligns with the government's vision to propel Indian brands in international markets, particularly in the food processing sector, as evidenced by the significant investment outlined in the Ministry of Food Processing Industries' annual report. CPAM's vision to catalyze product-oriented research and development in the agri and environment sectors is reinforced by its mission to enhance productivity, food safety, security, and inclusive growth through ICT and electronics-driven solutions.
- The center's objectives encompass controlling the quality and volume of agricultural lines, reducing infrastructure and food processing costs through 3D printing, fostering industry-driven economics, and promoting indigenous machinery and supply chains. Its scope includes designing and establishing Agri-Factory test beds, developing Agri-Factory technology, establishing a business office for self-sustenance, and preparing techno-commercial roadmaps for Agri-Factory development. The centre has trained 34 manpower, filed 2 IPRs and developed 2 proof of concept.

#### 5.4.7.7 Centre for Promotion of Additive Manufacturing: Renewable Energy & distributed Manufacturing using Customized 4D & 3D Technologies

- The project entitled as "Establishment of Center for Promotion of Additive Manufacturing (CPAM): Renewable Energy & Distributed Manufacturing using Customized 4D & 3D Technologies (CPAM: RE & DM), under AM initiative, has been established at Indian Institute of Technology, Mandi (Himachal Pradesh).
- The centre aims to focus on development of indigenous manufacturing technologies (3D printable material, 3D printing machines, DfAM, and 3D printed products) for the Renewable Energy Sector. Additionally, machine-independent low-cost solutions for Distributed Manufacturing will also be developed to promote AM based Distributed Manufacturing.
- The initiative focuses on building a sustainable ecosystem that supports decentralized production, development of green and smart materials, and advanced manufacturing processes. It also aims to strengthen skills in additive manufacturing, promote startups and IPR generation, and provide sustainable solutions tailored to the Himalayan region. The centre has trained 16 manpower and produced 6 publications.

#### 5.4.8 National Centre for Quantum Manufacturing Technology (NCQMT)

The National Centre for Quantum Material Technologies (NCQMT) at C-MET, Pune, established by the Ministry of Electronics and Information Technology (MeitY) aims to develop indigenous quantum-grade materials critical for India's quantum computing, communication, and sensing ecosystem. The Centre focuses on diamond, hexagonal boron nitride (h-BN), two-dimensional materials, superconducting films (NbN, NbTiN), and quantum dots to support next-generation quantum technologies. The Centre has successfully grown single-crystal and polycrystalline diamond substrates using an indigenous Microwave Plasma CVD system, achieving up to 1.5 mm thickness with high crystallinity. It has also synthesized large-area (100 × 50 mm) h-BN films and monolayer MoS<sub>2</sub>. Further, NCQMT has developed quantum dots (ZnS, ZnSe, ZnTe, AuAg, graphene, and perovskite) for optoelectronic and sensing applications. To strengthen translational R&D, NCQMT has partnered with M/s M/s HHV Advanced Technologies Pvt. Ltd (Bengaluru) and other industries for co-development of machinery, process and other quantum related technologies. The Centre has trained 25 specialized manpower, filed two IPRs on 2D material synthesis and large-area h-BN growth, and established key indigenous facilities including MPCVD, ALD, and CVD systems, confocal microscopy, and optical spectroscopy setups.

NCQMT is supporting the goals of the National Quantum Mission through indigenous innovation, technology transfer, and start-up incubation.

#### 5.4.9 MeitY-NSF: Machine Learning Guided 3D Printing of Self-Healing Sustainable Concrete from Waste Materials

- Concrete, primarily composed of Ordinary Portland Cement (OPC), is the most widely used construction material globally. However, OPC production contributes nearly 8% of human-induced global carbon emissions, making the development of sustainable alternatives a key environmental priority. Furthermore, the brittle nature of concrete leads to frequent structural damage due to environmental exposure. To address these challenges, the proposed project focuses on developing 3D-printed sustainable, self-healing concrete using industrial waste materials and marine organisms, supported by machine learning (ML)-driven autonomous printing technology.
- The project aims to create sustainable, self-healing concrete by replacing OPC and natural aggregates with spent foundry sand and recycled PET plastic, while incorporating carbonic anhydrase enzyme to enable autonomous crack healing through calcium carbonate deposition. It also targets multifunctionality through dual-nozzle 3D printing of multilayer concrete with silk–algae hydrogel coatings—silk waste providing thermal insulation and algae supporting CO<sub>2</sub> capture and O<sub>2</sub> generation.

#### 5.4.10 MeitY-NSF: Alloy Design and Processing Science for Additive Manufacturing of Rare Earth Permanent Magnets

- Additive manufacturing (AM) of rare-earth magnets is gaining importance for its ability to create complex designs with minimal material waste. These magnets are vital for green energy systems such as wind turbines and electric vehicles. The project focuses on developing AM processes to fabricate high-performance isotropic and anisotropic magnet.
- The project focuses on alloy design, process optimization, and fabrication of dense magnet with high coercivity. It aims to establish standardized AM processes, develop tailored alloy compositions, and explore potential for industrial-scale production. The objectives include achieving high coercivity, understanding process–microstructure correlations, and producing magnets with an optimal balance of remanence and coercivity.

#### 5.4.11 MeitY-NSF: Energy-Efficient Quantum Materials-Based Magnetic Tunnel Junctions for Unconventional Computing Applications

- Advancements in technology have created a demand for smaller, faster, non-volatile, and energy-efficient spintronic devices. Spin-based devices, such as magnetic memory (hard drives and MRAM) and spin logic systems, are also being explored for emerging computing paradigms like bioinspired, probabilistic, and Ising-based computing. The key challenge lies in identifying suitable materials that combine high speed, low power consumption, non-volatility, and long endurance. Magnetic tunnel junctions (MTJs), consisting of two magnetic layers separated by an insulating barrier, are central to many spintronic applications, including probabilistic computing.
- The project aims to develop quantum materials-based magnetic tunnel junctions (MTJs) for energy-efficient computing. It aims to overcome limitations of conventional systems through Stochastic Computing Computational Random-Access Memory (SC-CRAM) built on quantum MTJs.

#### 5.4.12 CoE on products based on Li-ion (Post Cell):

- In order to boost the mobile and other electronic industries in the country, a Centre of Excellence (CoE) for Products based on Li-ion Cells (Post-Cell) has been set up at CDAC Noida in association with the Industry Association – India Cellular and Electronics Association (ICEA) & financially sponsored by Ministry of Electronics

& Information Technology, Govt. of India and Department of IT & Electronics, Govt. of Uttar Pradesh.

- The CoE facility is created as a result of implementation of the MeitY funded project “Establishment of Centre of Excellence (CoE) for Products Based on Li-ion Cells (Post-Cell)”.
- CoE serving as a one stop facility centre for the design, development and testing of products related mobile handset accessories and other electronics applications. Specifically the products envisaged for development under CoE are Power Banks, Chargers, Wireless Chargers, Bluetooth Speakers, Smart Lighting Systems, Digital Radio, Headphones, Wearables, Solar Inverter, GPS Tag using NavIC, UPS System for IT Access, Power Tank, Access Control using RFID/Biometric.
- The project successfully completed in June 2025 and as per the directions of Governing Council of the project, the CoE facility is handed over to ICEA for operationalization for a period of two years. All the formalities for handover between C-DAC and ICEA are completed. The Centre is now named as “Electronics Design and Testing Centre (EDTC), Noida”.



## CAPABILITIES OF LAB

### Lab facility in CoE

- Analog & Digital RF Smart Lab
- PCB Development Lab
- Safety Lab
- EMI/EMC Lab
- Product Prototyping Lab
- Reliability Lab

### Design & Testing Equipment

- Digital Signal Oscilloscope
- E-Load & Power source analyzers
- Spectrum Analyzer
- Vector Analyzer
- Bluetooth Test Set
- 3D Printers with Polyjet resin Technology

### Design Software

- PADS Professional (Siemens)
- SolidWorks Professional with Flow simulation & Electronic Cooling Module

### Environmental Chambers

- Thermal Cyclic Chamber
- Thermal Shock Chamber
- Vibration Tester
- Salt Spray Machine
- Shock Test Machine



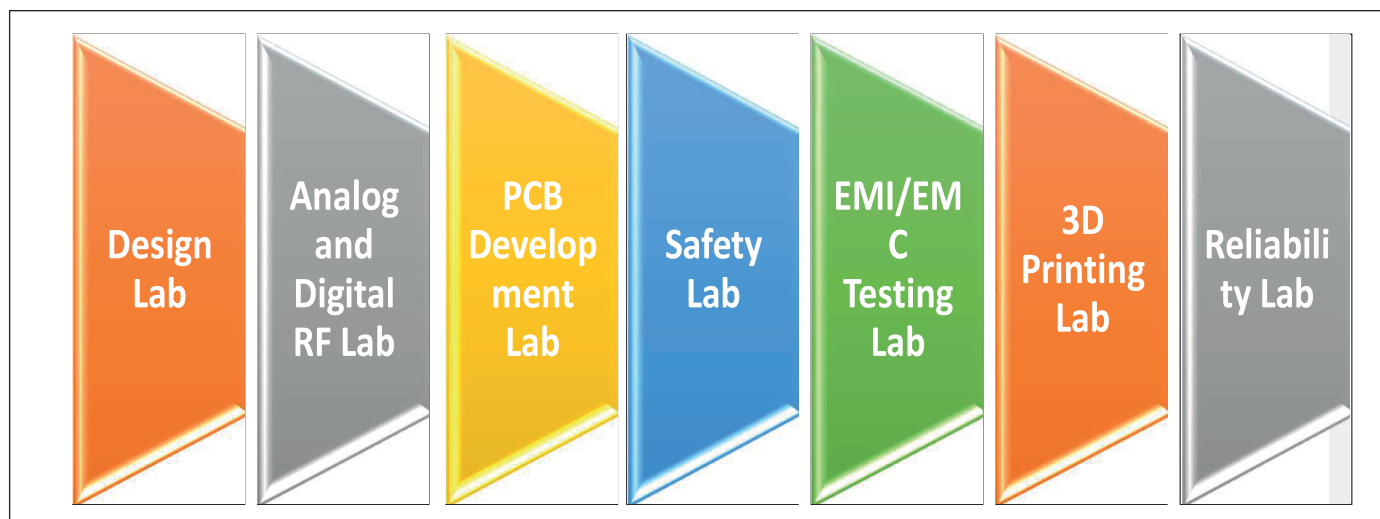

#### 5.4.13 Centre of Excellence (CoE) in Intelligent Internet of Things (IIoT) Sensors

Driven by major government initiatives and the nation's push for digitalization, smart infrastructure, industry 4.0 and automation, Smart Cities and domestic manufacturing, there have been significant growth in the sensor market in India. With the ever-growing numbers of connected devices through IoT, the need for IoT sensors have become imperative to monitor and control any system remotely sitting anywhere in the world. The IoT sensors, essentially find applications in diverse sectors including Health Care, Environment & Agriculture, Manufacturing, Energy management, Home automation, Smart Cities, Military & Space, Transportation etc.

Considering this growing demand for sensors and to evolve India as a global hub for sensor manufacturing, the Centre of Excellence (CoE) in Intelligent Internet of Things (IIoT) Sensors was established under the aegis of MeitY with the joint support of Government of Kerala. The CoE in IIoT sensors is jointly implemented by C-MET, Thrissur and IIITMK, Trivandrum.

Aiming to make India self-reliant in the emerging electronic technologies and for complete indigenization, as a part of this CoE, C-MET has developed various sensors such as thermal sensors, humidity sensors, smoke sensors, gas sensors, etc. These sensors were further integrated into IoT devices such as Smart Digital Thermometers, Industrial Fire Alarm, CO2 sensor modules and IoT Gateway. Many of these are tested for compliance with various standards and field trials are conducted through industrial partners. The CoE is also engaged in the development of many other sensors including particulate matter, pH, NPK, piezo sensors, etc. Under the CoE, several sensors were developed with different communication modules in-built. 15 startups were incubated with the CoE and several skill development programmes were conducted by the CoE.

The CoE is also committed to the following activities.

- R&D of various IoT enabled sensors for wide variety of applications
- Extending infrastructure and central facilities required for sensor manufacturing, system integration, followed by testing for pre-compliance.
- Establishing core testing lab facility that includes (1) Electromagnetic compatibility (EMC) pre-compliance for less than 26 GHz solutions, (2) Electrical, safety, Power, Signal Level Auto Test setups, (3) Environmental, Climatic, instrumentation, Vibration, Mechanical test Setup, (4) IoT system tests (including communication tests, 5G tests, Protocol tests, Modulation, Demodulation etc), (5) Accreditation and calibration support.

- R&D and pilot plant facilities for temperature, pressure, humidity, acoustic sensors at C-MET
- R&D manufacturing lab at Maker Village Annex at IIITM-K on multilayered PCB, system integration, and software testing.
- Establishing an incubator facility for SMEs/Entrepreneurs. The start-ups focused in the area of IIoT Sensors will utilize 90% of the centre
- Conducting skill based program for training Entrepreneurs and technicians
- Design, development and research consultancy to start-ups and SMEs
- Technology transfers of commercialization ready products

The CoE can also provide customized sensor solutions for the industries and start-ups. A few of such industry driven developments are indicated below

- CoE has developed Carbon dioxide sensor module with fully digitalized data acquisition, inbuilt temperature sensing, improved chamber reflectivity, and advanced compensation algorithms for both temperature and pressure.
- For easy integration into existing industrial systems, the RH sensors re-designed to facilitate seamless integration with industrial systems while maintaining high performance in terms of sensitivity, accuracy, and stability.
- For easy industrial adoption and deployment, smoke detectors were designed for functional enhancements such as a 'silent' mode for low sensitivity operation and 'interconnect' option which allows the alarm signal to be transmitted to other linked detectors to give remote indication alarm. The alarm triggering thresholds are adjustable, enabling reliable operation under varied environmental conditions. The smoke detectors were tested in accordance with IS standard IS:11360-1985 and qualified.
- Distinct ion-selective electrodes (ISEs) tailored to preferentially identify the activity of certain ions (primary nutrients for plant growth), enabling the measurement of Nitrogen (N), Phosphorus (P), and Potassium (K) are being developed for smart agriculture applications.
- As per industry requirement, thermal sensor integrated embryo culture system for improved success rate in IVF procedures was developed for an Indian industry.
- Developed Bluetooth-enabled digital thermometer for precise temperature monitoring within critical IVF equipments for a healthcare industry
- Six technologies were transferred to Indian industries for commercialization

#### 5.4.14 India Innovation Centre for Graphene (IICG)

The India Innovation Centre for Graphene (IICG) aims to advance research in graphene and other two-dimensional (2D) materials, with a strong focus on application-oriented, industry–academia collaboration. The Centre is jointly implemented by C-MET, Thrissur; Digital University Kerala, Thiruvananthapuram; and Tata Steel Limited, with financial support from MeitY, Government of Kerala, and Tata Steel Limited and other industries.

A process for making graphene-based conducting ink suitable for wireless electronic applications and a graphene-incorporated thermal interface material has been developed. In addition, several products and prototypes have been realized, including graphene-based heated gloves, heated water bottles, humidity sensors, flexible memristors, flexible heating pads for newborn infants, conductive inks, a graphene terracotta mobile amplifier, graphene supercapacitors, and a self-healing anti-corrosive coatings.

Products developed under IICG program were demonstrated at International Conclave on Next-Gen Higher Education held at Cochin University of Science & Technology, Kochi.

4 research articles have been published in National and International journals in the reported duration. And 19 patents have been filed, and 6 patents have been granted in the reported duration.

Training and fellowship activities have included M.Sc., M.Tech., Ph.D., and postdoctoral internships to support graphene-related research and product development. The i-Graphene Certificate Programme has offered courses on AI and Graphene Technology, Graphene Applications, and Graphene for Semiconductors. In addition, an academia–industry programme titled “RFIC Design and 2D Materials in Lithography” was conducted during 10–12 June 2024 in collaboration with Keysight Technologies, with participation from 51 faculty members, entrepreneurs, researchers, and industry.

#### 5.4.15 Startups, Innovation, IPR and Entrepreneurship

- (a) India has evolved as the 3<sup>rd</sup> largest startup ecosystem in the world with more than 2 Lakh startups operating in the country and more than 120 unicorns with a total valuation of more than \$ 350 Bn. Notwithstanding the raging global pandemic economic duress and other equally precarious challenges, the tech startup and the entrepreneurial ecosystem in the country have shown exemplary resilience and willingness to go beyond the norm. India now also boasts of more than 35,000 technology startups including more than 3,500 deep-tech startups operating in different segments of emerging technology areas.
- (b) Startups, Innovation, IPR and Entrepreneurship Division of MeitY has unleashed a slew of initiatives for the benefit of technology startups dealing in IT/ITeS and Electronics domains. These initiatives includes Technology Incubation and Development of Entrepreneurs (TIDE 2.0) Scheme, Gen-Next Support for Innovative Startups (GENESIS) Scheme, MeitY Startup Hub (MSH), Centres of Excellence (CoEs), Incubation Centre projects etc. Further, MeitY has initiated IPR Facilitation Program for supporting MeitY R& D societies and grantee institutes in filing IPR. Some of the initiatives have been elucidated here:
  - **GENESIS (Gen-Next Support for Innovative Startups):** MeitY has initiated overarching ‘Gen-Next Support for Innovative Startups (GENESIS)’ Scheme with a budgetary outlay of Rs. 490 Crore over a duration of 5 years to accelerate and enhance the fast-rising tech startup ecosystem. The Scheme aims to boost the startup ecosystem in Tier-II & Tier-III cities and upcoming towns in the country with emphasis on collaborative engagement among startups, government and corporates. The GENESIS Scheme is being implemented by Nodal Implementing Agency i.e MeitY Startup Hub (MSH) through 65 Implementing Agencies (IAs) across Tier-II and Tier-III cities of the country. The scheme envisages scaling up about 1,600 technology startups to discover, nurture and grow technology startups. Under the scheme, a total of 253 startups have been supported till now.
  - **MeitY Start-up Hub (MSH):** MSH has been set up as a nodal entity under MeitY to strengthen the deep tech startup ecosystem by aggregating, enabling and empowering the entrepreneurs and startups across India. MSH is aiming to integrate all startup centric resources, schemes, programs of MeitY via a comprehensive digital platform. MSH is assisting incubators and startups improving their scalability, market outreach, etc. and has also established partnerships with various stakeholders paving the way for an economy built on innovation and technological advancement. MSH has seen a consolidation of over 6000+ startups, 500+ incubators, 450+ mentors and 42+ state of the art Centres of Excellence (CoEs), conducted 143 challenges in different technology areas encouraging development of innovative products / services to address current and pressing challenges.
  - **TIDE 2.0 Scheme:** MeitY had initiated TIDE 2.0 scheme in 2019 with an outlay of Rs 264.62 Crores over a period of 5 years to promote tech entrepreneurship through financial and technical support to incubators engaged in supporting ICT startups using emerging technologies such as IoT, AI, Block-chain, Robotics etc. in seven pre-

identified areas of societal relevance. The Scheme is being implemented through 51 incubators through a three-tiered structure with an overarching objective to promote incubation activities at institutes of higher learning and premier R&D organizations, eventually leading to handholding of approximately 2000 tech start-ups over a period of five years. As of now 51 TIDE 2.0 Incubation Centres have been approved and made operational.

#### Key achievements:

- 1600+ startups supported
- 600+ Low engagement programmes conducted
- 85+ Deep engagement programmes conducted
- 140+ Challenge Grant/ Hackathons
- 510+ Training workshops Conducted
- 1200+ products/prototype/MVP Developed
- 300+ Patents filed
- 250+ Trademarks registered/ copyrights filed
- 300 Cr Turnover of graduated startups
- 600+ Startups graduated
- 11000+ Employments generated
- **Domain specific Centres of Excellence (CoEs):** To improve and transform innovation-led ecosystems in the country, MeitY in partnership with various stakeholders has opened a clutch of domain specific Centres of Excellence (CoE) in order to create cohesive technology solutions built around the emerging technologies and support the next wave of budding entrepreneurs pan India. A brief of such initiatives is put forth below:
  - **Centre of Excellence in AgriHub, Innovation hub for Agriculture (CoE) at IIT Indore:** MeitY has established a Centre of Excellence (CoE) in the field of agriculture at IIT Indore with a total budgetary outlay of Rs. 14.98 Crore including MeitY contribution of Rs. 11.32 Crore over a period of five years. The CoE has been setup in collaboration with the Government of Madhya Pradesh, IIT Indore, C-DAC Pune, ICAR–IISR Indore, ICAR–CIAE Bhopal, and various industry partners. The CoE aims to facilitate collaborations between academia, industry and government to bring cutting-edge technologies to agriculture, create a pipeline of startups and generate patents, collaborations, internships/workshops to mentor students/NGO/ framers and to address agricultural challenges. AgriHub CoE envisages execution of 46 Deep AgriTech Programs, 40 inventions, filing of 25 patents, incubation of 8 startups and facilitate 10 technology transfer and licensing agreements through startups. Under the project, a total of 11 Deep AgriTech projects have been supported.
  - **Centre of Excellence (CoE) on FinTech at Chennai:** MeitY has established a Centre of Excellence (CoE) in FinTech at STPI, Chennai with total budgetary of Rs. 10.82 Crore including Rs. 1.8 Crore contribution from MeitY over a period of five years to provide infrastructure, resources, coaching/ mentorship, technology support and funding to emerging start-ups in the FinTech sector. The CoE has been setup in collaboration with Government of Tamil Nadu, STPI as funding partners, M/s Intellect Design Arena Ltd, Yes Bank as knowledge partner, NPCI, UIDAI and Partner Banks. The purpose of the FinTech CoE is to create a holistic ecosystem so as to enable start-ups to experiment their innovative financial products or services within a well defined space and duration. The project aims to support 58 start-ups over a period of 5 years. Through this CoE, 61+ startups supported, 187+ products/prototypes developed, 27+ IPR filed, 1080+ employment generated, Rs. 26+ Crore revenue generated and Rs. 16+ Crore funding raised by supported startups.

- **IOT OpenLab-a Centre of Excellence (CoE) for Internet of Things at STPI Bangalore:** An IOT Open-Lab - a Centre of Excellence (CoE) for Internet of Things in partnership with Arrow Electronics at STPI Bangalore with a total budgetary outlay of Rs. 11.47 Crore including Rs. 1 Crore contribution from MeitY over a period of five years to provide academic and business mentoring of the startups in the IOT emerging technology area for developing products and/ or services around IoT along with networking opportunities for the startups. The CoE has been setup in collaboration with Arrow Electronics, STPI as funding partners. The IoT OpenLab intends to support and nurture 100 start-ups per year with an overall target to support 500 startups over a period of 5 years. Through this CoE, 103+ startups supported, 99+ products, 41+ prototypes developed, 73+ IPR filed, 3485+ employment generated, Rs. 247+ Crore revenue generated and Rs. 55+ Crore funding raised by supported startups.
- **ESDM Incubation Centre (Electropreneur Park) at Bhubaneswar by STPI:** MeitY has established ESDM Incubation Centre at STPI Bhubaneswar with a total budgetary outlay of Rs. 22.44 Crore including Rs. 2.5 Crore contribution from MeitY over a period of five years to create a holistic eco-system to promote ESDM innovation, R&D and create Indian intellectual property in the Eastern Region of the country. The centre was setup in collaboration with Government of Odisha, STPI as funding partners, IIIT Bhubaneswar and IESA. It aims to leverage 40 start-ups over the period of 5 years. This eco-system is necessary to develop, promote, incubate, mentor and create breakthrough innovations towards development of product and IP creation in the ESDM sector. Through this CoE, 38+ startups supported, 50+ products, 105+ PoC developed, 45+ IPR filed, 650+ employment generated, Rs. 14+ Crore revenue generated and Rs. 14+ Crore funding raised by supported startups.
- **Centre of Excellence (CoE) on Medi-Electronics & Health Informatics at Lucknow:** MeitY has established a Centre of Excellence (CoE) on Medi-Electronics & Health Informatics at SGPGI, Lucknow with a total budgetary outlay of Rs. 16 Crore including Rs. 3 Crore contribution from MeitY over a period of five years to stimulate the establishment and growth of technology-based start-ups in the field of medical electronics and health informatics by providing the necessary infrastructure, mentoring, marketing, funding and eco-system required for their success and growth. The Medi-Electronics & Health Informatics CoE has been setup in collaboration with Government of UP, STPI as funding partner, AiMED, AMTZ as industry partner and Kalam Institute of Health Technology as academic partner. The project aims to support 50 start-ups over a period of 5 years. Through this CoE, 53+ startups supported, 18+ products, 39+ prototypes developed, 8+ IPR filed, 510+ employment generated, Rs. 48.95+ Crore revenue generated and Rs. 3+ Crore funding raised by supported startups.
- **Centre of Excellence (CoE) in Emerging Technologies (EmTek) at Bhubaneswar with Satellite Center at Rourkela:** MeitY has established CoE in Emerging Technologies at STPI Bhubaneswar with a total budgetary outlay of Rs. 21.25 Crore including Rs. 6.13 Crore contribution from MeitY over a period of five years to support startups in Industry 4.0 technologies viz. Data Analytics, Machine Learning, Cyber Security & Artificial Intelligence (AI) & be the preferred Start-Up destination in Industry 4.0 in Odisha. EmTeK CoE has been set up in collaboration with Govt. of Odisha, MeitY, STPI as funding partners, NALCO, SAIL-RSP, Maxbyte as industry partners. The EmTeK CoE aims to support 150 startups over a period of 5 years. Through this CoE, 24+ startups supported, 5+ products, 20+ PoCs developed, 1+ IPR filed, 67+ employment generated, Rs. 1.8+ Crore revenue generated and Rs. 0.7+ Crore funding raised by supported startups.
- **Incubation Centre projects:** With an aim to support the economic development of local region through supporting start-ups and businesses that will lead to creation of a more vibrant local entrepreneurial ecosystem, various incubation centres under the aegis of MeitY has been setup across India. MeitY has initiated the following state of the art Incubation Centre projects:

- Setting up of Electropreneur Park Delhi 2.0 by STPI :** The Electropreneur Park Delhi 2.0 project has been established at IIIT Delhi with total budgetary outlay of Rs. 46.78 Crore including Rs. 16.30 Crore contribution from MeitY over a period of five years to create a holistic ecosystem for encouraging R&D, Innovation and entrepreneurship in the ESDM sector. The project has been initiated in collaboration with STPI, IIIT Delhi, IESA as continuation of the Electropreneur Park project supported by MeitY and implemented by STPI. The project aims to support 200 startups/MSMEs in the ESDM domain through Pre-Incubation, Incubation, Acceleration, MSME Launchpad and MSME Acceleration programs. It was envisaged to support 10 spoke centres preferably across North India for supporting 125 number of startups through Pre-incubation program, out of total target of supporting 200 startups/MSMEs. Under the project, a total of 10 startups are supported.
- Setting up of Incubation Centre at IIT Patna Phase -2:** Incubation Centre at IIT Patna Phase-2 established at IIT Patna to scale up its existing operations and widen the startup support by establishing four extension centres preferably at Tier 2/Tier 3 cities viz. Gaya, Muzaffarpur, Darbhanga and Bhagalpur so as to ensure accessibility of ESDM technical infrastructure across Bihar. The project has been initiated in collaboration with Government of Bihar with total budgetary outlay of Rs. 38.36 Crore including Rs. 14.8 Crore contribution from MeitY over a period of five years as continuation of the Incubation Centre at IIT Patna project supported by MeitY. The centre along with extension centres aims support 310 startups including 200 startups under pre-incubation program, 80 startups under incubation program, 30 startups under acceleration programs. Under the project, a total of 26 startups are supported.
- Walk for Life – First of its kind Health Incubator:** The project titled ‘Setting up of “Walk for Life” - First of its kind Health Incubator’ being implemented by Institute of Liver and Biliary Sciences (ILBS) with a total budget outlay of Rs. 7.5 Crore from MeitY as GiA over a period of 18 months. This project envisages the development of a screening tool which gives valuable information regarding a person’s development, cardiac ailments etc. and will also look into using a 3-Dimensional body scanner which is available commercially and develop it to make it suitable for healthcare applications through supported startups. The project is aiming to support at least 10-15 start-ups to develop products and/ or services in the field of healthcare and medical electronics
- IPR facilitation programme:** Under IPR facilitation programme of MeitY, The Startups, Innovation & IPR Division, MeitY has been supporting its R&D societies and grantee institutions under various R&D projects for filing of different IPRs namely Patents, Trademarks, Copyrights and Industrial designs. The support includes end to end facilitation including prior art search, filing and maintenance of the IP assets in the form of annuities. The assignee ownership of IPRs is as per terms & conditions governing the GiA for particular R&D project. Through MeitY IPR Patent facilitation 513 patents have been filed out of which 330+ patents were granted, 529 copyrights filed and 168 trademarks applied.

#### 5.4.16 The Software Industry Promotion Division (SIPD)

The Software Industry Promotion Division (SIPD) of MeitY promotes the growth of India’s IT/ITeS industry by enabling innovation, employment generation, and regional development. It supports startups, accelerators, BPO promotion, deeptech innovation, and IT infrastructure expansion, especially in Tier-II and Tier-III cities. SIPD also facilitates global market access for Indian IT enterprises and works to address policy and regulatory challenges, thereby contributing to India’s vision of becoming a global digital technology hub.

#### Indian Software & Services Industry

The Indian IT/ ITeS industry has a leading position globally and has been progressively contributing to the growth of exports and creation of employment opportunities. India’s IT-BPM industry (excluding e-commerce) is expected

to grow by ~5.20 % to reach at USD 283 Bn, including exports of 224.4 USD Bn in FY 2024-25 (E). The IT-ITeS Industry has also created large employment opportunities and is estimated to employ 5.8 million (58 lakh) professionals. Women employees account for 36% share in total industry employee base. IT-BPM industry accounts for 7.3% relative share in India's GDP. Today, India has 33,000+ tech start-ups and ranked 3 largest start-up ecosystem in the world. The phenomenal success of the IT-ITeS industry has been possible through the pivotal role played by the Software Technology Park (STP) Scheme and providing fiscal benefits under Section 10A of the Income Tax Act, which was available upto 31st March 2011. STP Scheme is a very unique scheme, designed to promote the software industry including innovations and growth of Start-ups and SMEs without any locational constraints.

## Initiatives by MeitY for promotion of IT/ITeS Industry

### Domain Specific Centre for Entrepreneurship (CoE)

#### NEURON at Mohali

STPI NEURON, a Centre of Entrepreneurship in AI/Data Analytics, IoT and AVG, set up in 2019 in collaboration with Govt. of Punjab, ISB-Mohali, PTU and MeitY, is a pioneering initiative to identify and evaluate promising startups in the field of AI/Data Analytics, IoT and AVG and nurture them to build path-breaking products and solutions in the domains the CoE focuses on. NEURON has dedicated 500 seats co-working space and labs for AI/Data Analytics, IoT and AVG. Apart from physical infrastructure, the hub has the access to industry, industry associations and academia to further strengthen the fostering of startups. This CoE has successfully onboarded 114 startups in AI, Data Analytics, IoT, and Animated Visual Graphics domains, achieving a cumulative valuation of ₹890 crore, with startups generating ₹44 crore in revenue, raising ₹51 crore in funding, and creating around 2,700 jobs. The CoE has facilitated 147 outreach events, 90 mentoring sessions, and supported 158 products, 171 prototypes, and 67 IPRs (46 granted). Notable products include AI-based cyber intelligence systems by *Evigway Technologies*, anti-money laundering solutions by *IntelleWings*, Healthcare Remote Interactive Machine (HCRIM) by *Medaara Technologies*, connected mobility platforms by *Waypals Systems*, and AI-enabled road anomaly detection systems by *HanuAI*. The CoE has been recognized with multiple awards from CII and DPIIT, and several of its startups have received national accolades and funding support, establishing NEURON as a leading hub for Tech innovation in North India.

#### MOTION at Pune

The STPI MOTION, a CoE in Automated, Connected, Electric & Shared (ACES) mobility space at Pune, creates a promising environment and provides necessary support to startups, young entrepreneurs and innovators in this domain in collaboration with government, industry, industry association and academia. The CoE has successfully onboarded 55 startups, resulting in 81 IPs filed (49 granted), fund mobilization of ₹40.69 crore, and the creation of 588 jobs. The CoE established a dedicated 10,000 sq. ft. facility at Bhosari, Pune, operational round-the-clock with advanced lab and co-working infrastructure. It conducted 389 mentoring sessions, extended testing and consultancy services, and fostered collaborations with Tata Motors, Kinetic Green, and Maha Metro, among others. Notable product successes include Attron Automotive's high-efficiency EV motors and controllers, Eidikos Business Enterprises' composite EV charging stations, Coulomb Li-Tech's proprietary lithium battery systems, and Exa Mobility's smart electric scooters. Startups like Combat Robotics and Kairus **Energies** have pioneered autonomous defense solutions and advanced energy storage systems, respectively. The CoE's mentorship network, industry partnerships, and specialized labs have accelerated innovation, making MOTION a key catalyst in India's transition toward sustainable and intelligent mobility.

#### FASAL at Akola

FASAL, an IoT in Agriculture CoE, has been set up at Dr. Panjabrao Deshmukh Krishi Vidyapeeth (Dr.PDKV), Akola in 2021 in collaboration with MeitY, STPI, Dr.PDKV, ioCare, Amazing Aerial Solutions, SatSure, The Indus Entrepreneurs(TiE) Mumbai & Indian Society of Agricultural Engineers to identify and evaluate promising startups in the field of AgriTech & Agri IoT and nurture them to build path-breaking products in the focused areas including Digital

Farming, Crop Protection & Management, Predictive Analytics & Hydroponic Vertical Farming System. This CoE has supported 38 agritech startups that have collectively achieved a valuation of over ₹323 crore, generated ₹10.98 crore in revenue, raised ₹5.23 crore in external funding, and created over 330 jobs. The CoE startups have developed 52 innovative products, 44 prototypes, and filed 38 IPRs (several granted). Notable innovations include AI-Genix's AI-enabled insect pest management system, Pakshimitra's IoT-based poultry automation solutions (iBrood, Spotless, Freedom), NIYO FarmTech's precision spray pump, AgroSonic's livestock management platform "GoatMate", and OMPRI Buildcon's fintech platforms GRAMePAY and GRAMeBIMA for rural inclusion. Other impactful products such as Hydenmet's "Krishi Vruddhi" crop advisory system, Aigret's electrostatic pesticide sprayer, and Omdatt Agrotech's IoT hydroponic tower showcase the CoE's role in fostering innovation-led, sustainable agri-entrepreneurship. The CoE has also piloted impactful initiatives like the Saffron Cultivation Lab in Vidarbha and "Krishi Vruddhi" IoT-based crop advisory, demonstrating measurable improvements in crop yield and farmer income, thereby contributing to innovation and rural entrepreneurship in the agritech sector.

### **Kalpatru CoE on Industry 4.0 at Rashtriya ISPAT Nigam Ltd. - Visakhapatnam Steel Plant (RINL-VSP)**

A CoE on Industry 4.0 has been set up at RINL Visakhapatnam to design and develop Industry 4.0 solutions for RINL-VSP, PSU's and other Industry present in and around Visakhapatnam as well as contribute to overall Indian Industry 4.0 requirements.

The demand for Industry 4.0 products & solutions is going to rise exponentially in the backdrop of growing Industrial Automation. Strengthening domestic capabilities of Industry 4.0 products & solutions will take the domestic industry up the valuechain significantly by way of increase in products, patents & IPRs. By capitalizing on the opportunities presented by Industry 4.0, the CoE shall boost start-ups in these fields and contribute to "Make-in-India" & "Digital India" programmes of Govt. of India by creating world class solutions locally.

With the above background, a CoE in the field of Industry 4.0 (Artificial Intelligence, Machine Learning, Augmented Reality, Virtual Reality, Industrial Automation, Industrial Robotics, Industrial Drone, Industrial IoT, Industrial 3D Printing and other related technologies powered by AI) has been approved for establishment at Visakhapatnam. This CoE plans to nurture 175 startups over a period of 5 years.

So far, 60 startups have been onboarded, resulting in the development of 24 products by these start-ups.

### **Next Generation Incubation Scheme (NGIS)**

Next Generation Incubation Scheme or "NGIS" is a futuristic & comprehensive incubation scheme entrusted by MeitY to STPI for implementation. NGIS has a vision to drive the rise of India as a Software Product Nation so as to make India a global player in development, production and supply of Innovative, Efficient and Secure Software Products (including embedded software). NGIS is focusing on 12 locations across India viz. Agartala, Bhilai, Bhopal, Bhubaneswar, Dehradun, Guwahati, Jaipur, Lucknow, Prayagraj, Mohali, Patna & Vijayawada. It shall support 300 startups/Entrepreneurs/SMEs in the field of IT/ITeS/ESDM and targets 50+ patent/IPRs from startups under NGIS.

NGIS has successfully concluded 20 challenge programs to date. Considering funding, stipend and mentoring support, a total of 686 startups have been supported so far. Out of these supported startups, 462 have received financial incentives. Of these, 180 startups have been funded, and 359 have been extended stipend support. This has resulted in creation of 1174 products, filing of 365IPRs and generation of 8519 employment opportunities. The incubation program has established a robust support ecosystem, featuring 219 mentors and 49 knowledge partners, with each location having a dedicated chief mentor, mentor pool, and knowledge partners.

Under the NGIS, startups have developed a diverse range of innovative digital products and solutions across key domains such as HealthTech, Agritech, EdTech, FinTech, Industry 4.0, Cybersecurity, and IoT. Prominent products include AI-driven health monitoring platforms, IoT-based smart farming systems, digital payment and compliance tools,

cybersecurity threat detection solutions, cloud-based learning management systems, and industry automation software. Many of these innovations have progressed to commercialization, received national and international awards, and are being deployed in sectors like healthcare, agriculture, logistics, and governance. Flagship innovations include AI-based healthcare platforms like *MEDHINI* by Arficus, eco-friendly batteries by *Felis Leo Widgets*, and smart infrastructure solutions by *Ecoprosus India*. Overall, NGIS has significantly strengthened India's digital innovation ecosystem and paved the way for the next generation of technology-driven enterprises.

### **The Startup Accelerator of MeitY for Product Innovation, Development, and Growth (SAMRIDH) programme**

The Government of India has launched a comprehensive initiative to foster innovation and support start-ups through its Startup Accelerator of MeitY for Product Innovation, Development, and Growth (SAMRIDH) program. The initiative addresses the need for accelerator programmes that can drive social impact and scale technology-driven solutions for India's emerging sectors. Under SAMRIDH, support is being extended to 300 technology startups through a network of existing and newly established accelerators in sectors such as healthtech, ed-tech, agri-tech, consumer-tech, fintech, SaaS, and sustainability. The programme provides financial assistance to selected accelerators for offering comprehensive acceleration services to startups, along with a matching fund support of up to ₹40 lakh per startup. It aims to enhance the capacity of accelerators in identifying and scaling promising IT-based startups by facilitating customer engagement, investor connections, and access to international markets.

SAMRIDH Programme has expanded its reach by engaging 42 accelerators across India with a total budget outlay of ₹99 crore. Since inception, the programme has accelerated 373 startups with matching funding for 241 startups.

### **iTamil Nadu Technology (iTNT) Hub in Chennai**

The Tamil Nadu Technology Hub (iTNT) in Chennai is a deep tech innovation Hub established to foster emerging technology ecosystems in Tamil Nadu. It is located on the Anna University campus and operates as a Section 8 company under the Tamil Nadu Department of Information Technology and Digital Services, supported by MeitY and the Tamil Nadu governments along with industries. The iTNT Hub was set up with a project cost of ₹54.61 crore over a period of five years. The primary objective is to nurture the deep/emerging tech innovation ecosystem in Tamil Nadu that can guide, develop, implement and support startups, especially in the scaling-up phase in Deep Tech. The iTNT Hub shall support 200 start-ups in the hub & spoke model and provide acceleration and infrastructural service. In addition, 200 numbers of start-ups will be accelerated in deep tech/emerging tech.

So far, 95 startups have been incubated, leading to the launch of 18 products, and 47 startups have been accelerated through acceleration programs.

### **Market Outreach initiatives**

#### **Business and Marketing Assistance Office for soft landing of Indian IT/ ITeS SMEs in USA and UK**

The Project envisages to assist Indian IT/ ITeS SME companies by providing them soft landing in existing infrastructure in USA and UK so that Indian IT SME companies can gain market access in a big way and propel their market share. Projects envisaged setting-up of two Business and Marketing (B&M) assistance offices for Indian IT SMEs in existing infrastructure for soft landing in USA (at east coast and west coast of USA) and setting up of two B&M Offices in UK in London and Manchester. A total of 30 companies in each identified country (5 noncompeting companies per year per center) is to be supported under these projects. By supporting collaborative yet non-competing Indian companies under one umbrella, the initiative encouraged synergy without overlap, enhancing the collective impact in the US & UK market. The initiative has also contributed significantly to boosting India's technology exports, strengthening the global competitiveness of Indian IT companies, and reinforcing India's image as a reliable and high-quality IT services provider in the international arena.

Importantly, it has raised awareness across the US market about the strengths and potential of Indian IT companies—particularly the agility, innovation and professionalism that MSMEs bring to the table. In many cases, the initiative directly enabled participating firms to establish their own offices in the US, marking a major milestone in their international expansion journey.

**Projects in North-East States of India**

- **Centre of Excellence with Start-Up Innovation Zones (CoE-SIZ)**

To incubate start-ups in new and emerging technologies in the areas of electronics and IT; provide a robust platform for start-ups, with single umbrella support services like mentorship services, cloud computing subsidy, seed capital assistance, marketing support (including IPR protection) etc., 8 Centre of Excellence with Start-Up Innovation Zones (CoE-SIZ) have been setup in each North East State in two phases. In phase-I, 3 CoE\_SIZ have been setup at Guwahati, Shillong & Imphal with an outlay of Rs. 30.7 cr in March 2020 while in phase-II, 5 CoE-SIZ at Kohima, Aizawl, Agartala, Itanagar & Gangtok have been setup with an outlay of Rs. 38.03 crore in March 2021.

Focus areas of CoEs in North East states:

Sr. No.	State	Location	Focus Area
1	Assam	Guwahati	Internet of Things (IoT) in Agriculture
2	Manipur	Imphal	Emerging Technologies (AR/VR)
3	Mizoram	Aizwal	Gaming and Entertainment
4	Sikkim	Gangtok	IT application in Healthcare and Agritech
5	Nagaland	Kohima	IT application in Graphic design
6	Arunachal Pradesh	Itanagar	GIS application including drone technology
7	Meghalaya	Shillong	Animation
8	Tripura	Agartala	Data Analytics and AI

So far, 293 startups have been onboarded under CoE-SIZ, resulting in the development of 68 prototypes and 264 products and employment to 1248 persons by these Startups.

- **Digital Startup Accelerator Program for North East (Digi-SAPNE)**

Digi-SAPNE program aims to support and accelerate the startups from North East Region (NER) to help them to scale into large ventures by creating technological solutions of societal impact thus promoting entrepreneurship and employment in the NER. The Digi-SAPNE initiative was approved on August 21, 2024, with an outlay of ₹5.76 crores for a duration of 3 years. It is aimed at supporting 36 startups (12 startups per cohort) from North East India. The first cohort of 12 selected startups from all eight states of North East have been completed successfully.

**5.5 Societal Reach R&D**

**5.5.1 Medical Tools, Equipments and Software**

- **Design and Development of Ultrasonic Transducer Probes for Medical Imaging:**

The project aims to develop indigenous Ultrasound (US) probes to reduce India’s dependence on imports and support the Make-in-India and Atma Nirbhar Bharat initiatives. It is a multi-institutional effort involving C-MET Thrissur, NIELIT Calicut, MCC Kannur. Under the project, the complete know-how of functional materials and backend electronics has been established, and prototypes of a 128-element curvilinear probe have been developed. The probe has been tested on a GE machine, and images of kidney and resolution phantoms were

successfully recorded and benchmarked against the GE-4C probe. It has also been validated as per ISO and IEC requirements for biocompatibility and electrical safety. Clinical trial protocols are approved, and fabrication of additional is in progress for clinical trials. These achievements mark an important step towards self-reliant medical imaging and open the path for developing advanced ultrasound transducers in India.

- **Self-contained X-ray blood irradiator system:**

The self-contained X-ray blood irradiator system uses high-dose X-rays to treat blood products and prevent transfusion-associated graft versus host disease (TA-GVHD) in immuno-compromised patients. SAMEER has developed two such units with financial support from MeitY. The system is fully shielded, safe, reliable, and provides a consistent high dose rate without requiring additional radioprotection measures.

Electrical safety testing has been completed and certification obtained. SAMEER has also received AERB authorization as an approved supplier of X-ray blood irradiator systems, and the CDSCO test licence is in place. All required AERB radiation safety QA tests have been completed and submitted for type approval, and the AERB inspection process is currently underway. Once type approval is granted, the indigenous system will be deployed at the user hospital for clinical validation.

- **Design and Development of EEG Based Real-Time Depth of Anesthesia (DoA) Monitoring System:**

The project aims to develop an indigenous real-time Depth of Anesthesia (DoA) monitoring system using EEG signals. A machine learning model is being trained on a locally compiled clinical EEG database, which will help improve the accuracy of DoA estimation for all age groups and for different anesthetic drugs. The trained model is implemented on an FPGA to validate the software results on hardware.

Clinical EEG data from 1,581 surgical patients have been collected and processed. Using reverse feature elimination, 11 key EEG features were identified. A Neural Network Regression model was developed. The hardware architecture for the Pre-Processing Unit, Feature-Extraction Unit, and Machine Learning Unit has been designed, implemented on FPGA, and successfully validated with clinical data. An FPGA-based prototype was also tested in real time during surgery at JNIMS Imphal. The ASIC design, including RTL and physical design, has been completed, and a fabrication of ASIC is yet to done.

- **Development of focused Compact Microwave Hyperthermia Applicator for small cancerous tumors:**

The project aims to design and develop a non-invasive, compact, and focused hyperthermia applicator operating in the ISM band (2.45 GHz) for the treatment of superficial melanoma lesions and small tumors located in sensitive regions such as the face, neck, and nose. By combining focused RF power delivery with integrated temperature monitoring, the system provides a precise and localized therapeutic option for controlled hyperthermia treatment.

A prototype applicator has been successfully designed, fabricated, and evaluated (Fig. 1a). The applicator uses a double-spiral antenna along with a reflector structure (Fig. 1b) to improve forward radiation and achieve better focusing at the target depth. Experimental testing was carried out to study temperature rise and Specific Absorption Rate (SAR) using ex-vivo tissue samples (Fig. 1c) and head-simulating liquid phantoms (Fig. 1d) at 2.45 GHz.

The primary objective of these measurements was to quantify the SAR distribution at different depths inside the phantom to assess the focusing capability and therapeutic effectiveness of the applicator.

- **Development of High Energy Linac for Medical and other Applications**

The project focuses on the design and development of a high-energy electron Linear Accelerator (LINAC) capable of accelerating electrons up to 30 MeV with a beam power of 5–10 kW. Such a LINAC has significant applications in medical radioisotope production (especially Mo-99/Tc-99m), neutron imaging, non-destructive testing, and

various industrial processes. Unlike reactor-based isotope production, this accelerator-based approach avoids the use of hazardous or fissile materials, generates minimal nuclear waste, and offers lower normalized capital costs.

The system has now been fully integrated, and vacuum processing is in progress. A stable 20 MeV electron beam has already been achieved, and further energy upgradation to reach 30 MeV will be attempted soon. The entire control system for the accelerator complex has been designed and developed by SAMEER and is fully functional. All hardware tests have been completed, and the integrated control console successfully synchronizes all devices, manages interlocks, and coordinates all subsystems. Fine-tuning of the console is currently under way to ensure optimal system performance.

Once fully commissioned, the high-energy LINAC to be housed at INMAS will enable reliable production of medical radioisotopes such as Molybdenum-99, which can be supplied to hospitals across the country for diagnostic use.

- **Integrated Surgical Platform with Navigation, Robot, Simulation & Training for Total Knee Arthroplasty:**

This initiative is developing an indigenous, affordable surgical guidance platform for Total Knee Arthroplasty (TKA). The system is implant-agnostic and supports both image-based and imageless workflows, reducing dependence on imported navigation and robotic systems.

During the year, all three components—Navigation, Robotics, and Simulation—progressed to TRL 3, with early prototypes demonstrated to surgeons. They are now moving through TRL 4 with improved workflows, safety design, and integration. The project has moved from concept to functional prototypes within a year and is on track to deliver a world-class indigenous TKA surgical guidance platform for Indian hospitals.

Next year, the Navigation System will advance toward TRL 6 with integrated prototypes, bench tests, and cadaver trials. The Robot System will complete its TRL 4 prototype and start regulatory validations. The Simulation System will expand VR/haptic training modules.



# 6

## CHAPTER

# Internet Governance and Security of Cyber Space

## 6.1 Internet Governance Overview

Internet Governance, broadly defined, is the development and application by Governments, private sector and civil societies, in their respective roles, of shared principles, norms, rules, decision making procedures and programmes that shape the evolution and use of the internet. It includes development and coordination of technical standards, operation of critical infrastructure and public policy issues.

### Conceptually Internet Governance includes following layer

- Physical Infrastructure layer
- Code or Logical layer
- Content layer
- Security layer

Internet Governance involves IP addressing, Domain Name System (DNS), Routing, Technical Innovations, Standardization, Security, Public Policy, Privacy, Legal Issues, Cyber Norms, issues pertaining to Intellectual Properties and taxation.

### 6.1.1 Achievements

Some of the significant achievements of MeitY includes representation of India's Public Policy concerns on global platforms, creating awareness on Internet Governance, encouraging greater participation in Internet Corporation for Assigned Names & Numbers (ICANN), WSIS, Internet Engineering Task Force (IETF) working groups, engagement with Internet Society (ISOC), promotion of multistakeholder model of Internet Governance in India etc.

#### 6.1.1.1 Engagement in International Forums/ Meetings

- The Internet Governance Forum (IGF):** Serves to bring people together from various stakeholder groups as equals, in discussions on public policy issues relating to the internet. India's concerns on the issues of public policy of the internet and its governance are appropriately voiced in meetings of the IGF through regular participation, multi-lateral and bi-lateral meetings. While there is no negotiated outcome, the IGF informs and inspires those with policy making power in both the public and private sector at their annual meetings, delegates discuss, exchange information and share good practices with each other. The IGF facilitates a common understanding on how to maximize internet opportunities and address risks and challenges that may arise. During the WSIS+20 Review High-Level Meeting held at the United Nations General Assembly in December 2025, the mandate of the Internet Governance Forum (IGF) was reviewed. It was decided to establish the IGF as a permanent structure of the United Nations, with greater participation from governments and other stakeholders from developing countries and underrepresented communities.
- Internet Corporation for Assigned Names & Numbers (ICANN):** MeitY is actively involved with the activities of ICANN and participates in its proceedings through the Government Advisory Committee (GAC) and other public

engagement fora. The GAC's key role is to advise ICANN on issues of public policy and especially where there may be an interaction between ICANN's activities or policies and national laws of international agreements. The Joint Secretary MeitY, Government of India, is currently the GAC representative from India. The ICANN85 Mumbai Community Forum will be hosted by the National Internet Exchange of India and the Ministry of Electronics and IT (MeitY) at Mumbai, India during 7 - 12 March, 2026.

- c. **WSIS+20 Forum High Level Event:** The WSIS+20 Forum High-Level Event is convened with the objective to take stock of the achievements and key trends, challenges and opportunities since the Geneva Plan of Action in 2003. The WSIS+20 High-Level Review Meeting was held at the United Nations General Assembly in December 2025, during which a comprehensive review of twenty years of the World Summit on the Information Society (WSIS) was undertaken. Member States negotiated and adopted the WSIS+20 review outcome document. India actively participated in the negotiations leading to the adoption of the WSIS+20 review outcome document.
- d. **APNIC:** The Asia Pacific Network Information Centre (APNIC) serves as the Regional Internet Registry (RIR) that allocates and manages IP addresses and ASNs in the Asia-Pacific region. India actively participates in this event to discuss policy matters. The APNIC 62 will be hosted by NIXI in collaboration with MeitY in September, 2026.

#### 6.1.1.2 India Internet Governance Forum (IIGF)

IIGF is a multi-stakeholder forum wherein representatives from various internet stakeholder groups convene together to discuss public policy issues pertaining to the Internet. It plays a pivotal role in representing Indian interests at the larger International policy and stakeholder discussions. This is a national initiative of the United Nations IGF. The Fifth edition of the IIGF was held during 27<sup>th</sup> – 28<sup>th</sup> November, 2025, in New Delhi with the theme Advancing Internet Governance for an Inclusive & Sustainable Viksit Bharat.

#### 6.1.1.3 Multi-stakeholder consultations

India supports multi-stakeholder model of Internet Governance, which would involve all stakeholders and helps to preserve the character of the internet as unified, dynamic engine for innovation and which encourages equity and innovation.

#### 6.1.1.4 Special Interest Groups (SIGs):

To establish a unified, collaborative, inclusive, and sustainable framework for internet governance in India, Special Interest Groups (SIGs) have been constituted. These groups serve as an institutional mechanism to:

Strengthen national capacity in internet governance.

- i. Promote India's global interests and participation in digital policy discussions.
- ii. Ensure meaningful stakeholder engagement in global forums such as ICANN, APNIC (Asia-Pacific Network Information Centre), IGF (Internet Governance Forum), and WSIS etc.

Three SIGs have been created, focusing on:

- i. Domain Names & Numbers
- ii. Internet Protocols and Standards
- iii. The Future of the Internet

Each SIG has defined Terms of Reference (ToRs) and includes members from academia, civil society, and the technical community to ensure effective engagement and policy alignment.

### 6.1.1.5 Promotion of Universal Acceptance

MeitY is working towards the implementation of a multilingual internet to enable all Indians to connect to and use the internet by ensuring that Internet domain names in languages other than English (Hindi, Marathi etc.) can be issued and used by all internet enabled applications, devices and systems. भारत- (Internationalized Domain Name) is now available in 10 scripts covering 22 scheduled languages of India. With the launch of .Bharat, end users may book domain names in all scheduled Indian languages.

Universal Acceptance (UA) is a global effort to drive a more inclusive and multilingual internet. MeitY in support from NIXI hosted the regional-level event on 3<sup>rd</sup> Universal Acceptance (UA) Day on 28th March, 2025. India, has been chosen as the flag bearer to promote and promulgate UA for digital inclusion. The event is a serious effort to initiate thought-provoking, meaningful and result oriented dialogues to raise awareness, break the language barriers and make the internet accessible to a larger population and bring every citizen in the ambit of economic progress.

### 6.1.1.6 The Research, Development and Awareness agenda under Internet Governance

Various projects have been initiated to have evidence-based research which will build capacity for India's participation in multiple international fora and also strengthening domestic policy related to internet. The projects would lead India to become a model centre and provide thought leadership in DNS and DNS security related technologies, conducting high-end research in DNS Security, building internal competencies in DNS Security by offering advanced training programs and establish a test-bed of DNS for research and training. The outcomes of the projects in IG would enable meaningful and sustained engagement in internet governance institutions (International) and processes with particular focus on the ICANN, IETF etc.

### 6.1.2 Projects under Internet Governance Division:

A. Advanced Internet Operations Research in India (AIORI) Phase-II (Building Internet Engineering & Standards Ecosystem in India) funded by NIXI: The AIORI project has been a pioneering effort in India in field of Internet measurement, DNS and resiliency research and has been capable of producing a production ready testbed for India and the world which is capable of:

- Finding new models and practices of resilient deployments of CII (Critical Internet Infrastructure).
- Measuring quality metrics of internet from end users' perspective.
- Research on next generation DNS
- A platform which can be used to code and test protocols
- A testbed for researchers in internet standards
- Work in sync with the world on internet evolution

Under this project, we are focused on creating an accurate Geo IP database for India and developing tools for last-mile performance measurement and troubleshooting for ISPs.

B. IG SIM- Internet Governance Structured Implementation Module Phase-II by CDAC, Delhi: The project envisages to provide technical and policy support to conduct Research, Training and Workshops and preparation of position paper, technology reports etc. on various Internet Governance Technology and Policy related issues.

IG-SIM would take forward the work of reviewing the global internet policy & technology landscape and provide assistance w.r.t. structured implementation on matters related to Internet Governance taking into account of rapid technical developments and dynamically changing needs to provide ongoing implementation support to IG related activities of the Government of India, Ministry of Electronics and Information Technology (MeitY).

- C. Next-Generation Internet Names, Services and Standards (NGINSS) by CDAC Bangalore: The objectives of the project are to develop an AI-based Trusted Notifier for malicious domains and deployment of a Secure DNS Resolver, along with identifying domain names misusing the “.in” string and monitoring their maliciousness.

## 6.2 National Internet Exchange of India (NIXI)

NIXI is a not-for-profit organization set up under section 25 of the Companies Act, 1956 (now section 8 under Companies Act, 2013) for peering of ISPs among themselves and routing the domestic traffic within the country, with seed funding from the Ministry. NIXI is performing the following three activities.

- Internet Exchange
- .IN Registry and Internationalized Domain Names (IDNs)
- National Internet Registry (NIR)

**Internet Exchange:** 78 Internet Exchange Nodes are functional across the country. The Internet Exchange nodes have been successful in ensuring peering of ISPs among themselves for the purpose of routing the domestic traffic within the country, instead of taking abroad, thereby resulting in better quality of service (reduced latency) and reduced bandwidth charges for ISPs by saving on International Bandwidth. The maximum volume of Internet traffic being handled by NIXI at present is 1.53 Tbps with 315 members including CDN.

Recently NIXI has introduced Bilateral peering along with existing Multilateral peering. CDNs are allowed to connect at NIXI exchange points free of cost (zero port charges). Once CDNs are onboard, more and more ISPs shall connect at Exchange points. All functional NIXI nodes are IPv6 ready.

**.IN Registry and Internationalized Domain Names (IDNs):** NIXI also manages the .IN registry ([www.registry.in](http://www.registry.in)). 203 Registrars have been accredited to offer .IN domain Name registration worldwide to customers. This has helped proliferation of web hosting in the country and promotion of Indian language content on the Internet. Over 3.82 million .IN Domain names have been registered. IDN's in all 22 official languages are launched and over 0.31 million IDNs domain names have been registered.

**National Internet Registry (NIR):** NIXI is also responsible for the National Internet Registry (NIR) for India named as Indian Registry for Internet Names and Numbers (IRINN). IRINN is responsible for delegation of IP addresses and AS numbers within the country. Over 4629 affiliates have joined IRINN. NIXI has delegated over 15.58 billion IPv6 and over 10.63 million IPv4 addresses.

Besides the three functions above, NIXI also undertakes training and workshop for Network managers and other Technical engineers in co-operation with Asia Pacific Network Information Centre (APNIC). NIXI has also prepared an audio visual of comparison of IPv6 with IPv4 and launched it in various social media platforms. NIXI has also hired a training agency for providing training on IPv6 fundamentals by way of video recordings which gets published on NIXI Academy for mass level capacity building.

## 6.3 Security of Cyber Space

### 6.3.1 Overview

Cyberspace refers to the virtual computer world and more specifically, is an electronic medium used to form a global computer network to facilitate online communication and dissemination of information. It is a complex environment of people, software, hardware and internet. Today, cyberspace is the common platform being used by citizens, civil society, businesses and Governments for messaging, communication and dissemination of information online, e-services, e-transaction, etc. As the cyberspace is virtual, borderless and offers complete anonymity, attacks can be launched from anywhere in the world with limited possibility of trace back and positive attribution. Emerging technologies such as

Internet of Artificial Intelligence (AI), Machine Learning (ML), Things (IoT), 5G, etc, are going to add various connected devices in cyberspace in near future. Cyberspace has been facing many security challenges due to emerging cyber threats and widespread use for social media and increasing e-transactions.

MeitY has taken a no. of legal, technical and administrative policy measures for addressing cyber security challenges. This includes National Cyber Security Policy (2013), Guidelines on Information Security Practices for Government Entities (2023), enactment of Information Technology (IT) Act, 2000 and setting-up of Indian Computer Emergency Response Team (CERT-In) for 24x7 cyber incident response under the IT Act, 2000, Cyber Security R&D and Capacity Building in Cyber Security.

### 6.3.2 National Cyber Security Policy (NCSP)

NCSP, 2013 was released for public use in July 2013. The policy caters to the cyber security requirements of Government and non-Government entities as well as large, medium & small enterprises and home users. The policy recognises the need for objectives and strategies that need to be adopted both at the national level as well as international level. The policy aims at facilitating creation of secured computing environment and enabling adequate trust and confidence in electronic transactions and also guiding stakeholders' actions for protection of cyber space. Considering the technological advancements, delivery of services through cyber space and the changing nature of cyber threats over the years, Government of India has formulated the National Cyber Security Strategy (NCSS), which will enhance the objective and implementation of NCSP, 2013. The NCSS is under the process of approval.

### 6.3.3 Guidelines on Information Security Practices for Government Entities

Guidelines on Information Security Practices for Government Entities have been circulated to all Central Ministries/ Departments, State/UT Governments and government organisations for compliance in order to strengthen cyber security. The purpose of these guidelines is to establish a prioritized baseline for cyber security measures and controls within government and their associated organisations. The guidelines shall assist security teams to implement baseline and essential controls and procedures to protect their cyber infrastructure from prominent threats. These guidelines shall also act as baseline document for administration and audit teams (internal, external/Third-party auditors) to evaluate an organisation's security posture against cyber security baseline requirements.

### 6.3.4 Grand Challenge for Start-ups

To promote innovation and entrepreneurship spirit in the country, the first version of Cyber Security Grand Challenge (CSGC) for Start-ups was launched on 15<sup>th</sup> January 2020, which was concluded in November 2021. Based on the success of Grand Challenge (CSGC) version 1.0, the Cyber Security Grand Challenge version 2.0 (CSGC 2.0) has been initiated and launched on 15<sup>th</sup> January 2025. Under the CSGC 2.0, participants need to create solutions around six defined problem statement areas which include, API Security, Data Security, Wearable Device Security and Privacy, Clone and Fake App Mitigation, AI for Threat Detection and Incident Response, and Securing Next-Generation Biometric System. The competition spans four progressive stages—Idea, Minimum Viable Product, Final Product, and a new GotoMarket phase—offering staggered funding. Currently, Final Product stage winners have been announced and GotoMarket phase is under process.

### 6.3.5 Public Procurement (Preference to Make in India) Order for Cyber Security Products

In furtherance of the Public Procurement (Preference to Make in India) Order 2017, notified by Department for Promotion of Industry and Internal Trade (DPIIT)(erstwhile Department of Industrial Policy and Promotion (DIPP)) vide notification No. P-45021/2/2017-B.E.-II dated 15.06.2017 and partially modified order No. P-45021/2/2017-PP(BE-II) dated 28.05.2018 to encourage 'Make in India' and to promote manufacturing and production of goods and services in India with a view to enhancing income and employment, MeitY notified a Public Procurement Order on 6<sup>th</sup> December 2019

for promoting and giving preference in procurement to indigenous Cyber Security products by Government entities, with the details of (a) indicative categories of cyber security products and (b) a format for self-declaration regarding 'local supplier'.

### 6.3.6 Notification of Forensic Labs as 'Examiner of Electronic Evidence' under Section 79A of the Information Technology Act, 2000

Section 79A of the Information Technology Act, 2000 mandates the Central Government to notify Examiner of Electronic Evidence for the purpose of providing expert opinion on evidence in electronic form before any court or other authority. For identification and selection of Examiner of Electronic Evidence, MeitY has designed and developed a scheme, initially to access and notify Forensic Labs as an Examiner of Electronic Evidence on the pilot basis. So far, 21 Cyber Forensics Labs have been notified by MeitY which are available at <https://www.meity.gov.in/ministry/our-groups/details/cyber-security-division-gNxIDOtQWa>

### 6.3.7 CyberShakti

Empowering Indian Women Government Officials in Cybersecurity is funded by MeitY with implementing agency as CDAC Noida to develop the women workforce in cybersecurity. The target is to train 1000 women employees from various State/UT Governments, Government organizations and PSUs through beginner-level and advanced-level courses in online and offline modes respectively. Various tools for cyber security capability assessment and enhancement of the participants/organizations such as Table Top Exercise, Capture the Flag (CTF) and Cyber Drill are also being developed under the project. So far total 578 Women Government Officials have benefitted through beginner level and advanced level training programme. Half day workshops to sensitize the women officials about the importance of cyber security and the existing cyber laws have also been conducted for 477 participants.

## 6.4 R&D initiative under Cyber Security

Cyber Security is one of major initiatives identified for securing cyber space. R&D in Cyber Security focusses on promotion of applied research in addition to futuristic and blue-sky research in the thrust areas of Emerging technologies - IoT, end point security, network and system security, cryptography, cyber forensics, threat intelligence and AI based threat modelling. Grant-In-Aid support is extended to research institutions & academia to promote R&D infrastructure creation, capacity building and enhancement of skills and expertise, specific efforts are made to nurture institutions and capacity enhancement in the entire country with extra efforts for capacity building in the North East Region

The R&D projects funded have resulted in the development of indigenous security solutions which are deployed at user organisations. A few significant outcomes are as below:

### 6.4.1 Secure Networks and Edge-Computing Hardware for Industry 4.0

This project is being implemented by IIT Delhi. It involves two work packages(WP), WP1 handles secure testbed development with reactive adversaries, whereas WP2 addresses security edge computing solutions for industry 4.0 use cases. WP1 comprises Design and Development of Communication Protocols against Denial-of-Service threats from reactive adversaries. Under this Protocol designs and their performance analysis have been completed under generalized energy detectors and development of Key-exchange algorithms under reactive adversaries have been completed. WP2 comprises development of Edge computing apps --> secure compressed channel (link with WP 1) --> secure enclave on server --> HW protection of server chip --> secure app. Under the project, following are the significant outcomes:

- a. Transfer of Technology done for Efficient depth estimation system to Whitetree Devices Pvt., Ltd. that minimizes algorithmic and random flickering noise in stereo cameras.

- b. Edge computing hardware for simultaneous encryption and compression has been developed.

#### 6.4.2 Design and Development of Advanced Forensics Data Analytics Tool

The project is implemented by a consortium of CDAC Trivandrum, CDAC Bangalore and IIT Palakkad, where CDAC Trivandrum is the lead implementing agency. The other collaborative agencies include Federal Bank, Kerala State Forensic Science Lab (KSFSL) and Kerala State Electricity Board (KSEB).

Under the MeitY funded project “Design and Development of Advanced Forensics Data Analytics Tool”, CDAC Trivandrum launched the enhanced versions of the Cyber Forensics Tools, CyberCheck - a Forensic Data Recovery & Analysis tool, Win-LiFT - Windows Live Forensics Tool Suite, Advik CDR Analyzer - A Call Data Record/IPDR Analysis Tool, Web Investigator - Internet Forensics Tool for Windows Computers, Photo Examiner - An Image Forensics Tool, and Truelmager - Portable disk imaging hardware solution.

#### 6.4.3 Network Telescope Feed for Threat Intelligence Generation

The project aims to advance the development and deployment of a Network Telescope, emphasizing improved performance and expanded features. Tasks include refining the existing prototype with additional functionalities, deploying the Network Telescope to collect real-time Internet Background Radiations generated by malicious activities like scans, worm propagation, password cracking attempts and botnet operations. Development of tools/APIs for sharing Network Telescope data with CERT-In/NCCC will facilitate query based extraction of protocol fields, country of origin, Autonomous System Numbers, timestamps and Internet Service Provider information from the collected data. Efforts will focus on enhancing the visibility of the Network Telescope by expanding it to cover larger IP blocks. The project intends to supply data feeds to support comprehensive threat intelligence generation and to create a repository of Internet Background Radiations for future trend analysis. Additionally, research will concentrate on Network Telescope-centric Threat Intelligence, exploring techniques like TI scoring, analysing malicious patterns in packet payloads, detecting singletons within other sources of threat intelligence and investigating the application of AI and ML techniques for identifying unique security patterns and emerging trends.

#### 6.4.4 Detecting Adversarial Machine Learning

This project facilitates smart applications such as smart homes and smart manufacturing; energy constrained devices are inter-connected through bandwidth constrained communication protocols to form the internet-of-things (IoT).

Due to such constraints, an IoT network fails to employ conventional security protocols, which makes them vulnerable to security threats. One resource-efficient way to secure the IoT network is to deploy a comprehensively trained machine learning (ML)-based intrusion detection system (IDS). However, the existing IDSs are vulnerable to adversarial machine learning (AML)-assisted attacks that occur during the inference phase of the ML model, i.e. when the IDS employs the ML model for analysing specific network traffic to determine the presence/ absence of a malicious attack. In an AML-assisted attack, the attacker makes carefully crafted perturbations in the network packets with the goal to evade detection by the IDS. In this project, our objective is to resolve this issue by developing an AML-resilient IDS for detecting AML assisted attacks in IoT networks. We also plan to set up an IoT testbed and conduct extensive experiments to evaluate the effectiveness of the proposed IDS.

#### 6.4.5 Malware and Malware-based attack Detection Using Statistical and Machine Learning Approach

This project aims to counter the escalating threat posed by malware and malware-based attacks on the Internet and its services, extending beyond traditional devices to include IoT networks and critical infrastructures. The focus is on leveraging machine learning for defence solutions. The project is organized into seven modules: (i) establishing testbeds for experimental analysis and visualization of malware, (ii) generating benchmark malware datasets for Android

and Windows platforms, (iii) defending against known malware using supervised learning, (iv) integrating malware defence by combining grey level and feature data, (v) enhancing the prototype with early responses for unknown malware on CPU GPU platforms, (vi) detecting malware-based attacks on critical infrastructure and (vii) supporting the prototype with a dynamic signature-based mitigation technique for fast and accurate detection of both known and unknown malware.

The overall goal is to address the evolving nature of cyber threats by developing dynamic defence mechanisms through machine learning techniques.

#### 6.4.6 Centre on Hardware Security: Hardware Security Entrepreneurship Research & Development (HERD)

The project aims to promote research and entrepreneurship in hardware security. The project is implemented by a consortia of leading hardware security institution IIT Kharagpur, IIT Madras and Data Security Council of India, which is creating a national ecosystem for cyber security research and entrepreneurship through National CoE. The goal is to make India the leading nation in hardware security, both in research and entrepreneurship. The objectives are:

- **Promotion of Hardware Security Research:** Set up a well-devised research agenda in hardware security focusing on contemporary and emerging challenges. Promote hardware security research and ensure concerted efforts for measured and visible progress in the research work.
- **Productisation and Commercialisation of Research IPs:** Create market-ready IPs in hardware security, focusing on productisation and commercialisation. Run a focused incubation and acceleration program for start-up activities in hardware security. Develop market and investment ecosystem industry adoption and innovation growth.
- **Pool of Hardware Security Researchers:** Develop a pool of resources for hardware security research and product development. Attract minds of engineering students to address challenges of hardware security.
- **Support to Hardware System Assurance Efforts:** Develop formal methods, tools, and utilities assessing the security and trustworthiness of hardware/cyber systems. Support hardware and embedded assurance efforts with them.
- **Methods and utilities for Supply Chain Security:** Close observations on the hardware components, their role in the supply chains, investigate them for security threats, devise utilities for helping assess their security, and evolve methods for managing the risks emanating from them.
- **Sectoral Hardware Security:** Examine hardware and embedded systems deployed in the industry verticals and undertake experimental evaluation/ assessment exercises. Develop test cases for testing, carry vulnerability research, and help in devising hardening guidelines.
- **Enterprise Systems for Managing Hardware Security Risks:** Explore ways, methods, and techniques for enterprise systems to manage hardware-level threats on a real-time and continual basis.

#### 6.4.7 Efforts / activities in North Eastern (NE) States

Ministry of Electronics and Information Technology (MeitY), Govt. of India has taken initiative as per NE Vision 2022, with the broad vision of providing cybercrime investigation skills effectively. Major projects in NE states include:

- **Initiative for Cyber Security Aware Society in NE States:** Cross Platform Mobile Application developed to initiate cyber security aware society. The prime objectives of the project are to raise overall awareness about risks in cyber space targeting different sections of society by designing and conducting audience specific campaigns to create impact, so that people before connecting to online world, understand the risk and vulnerabilities in cyber space; and would be in a position to promote the use of cyber security resources and tools for carrying out

a number of awareness programs with the aim to encourage participation in cyber security focused activities in each district of the three states, viz. Nagaland, Mizoram and Sikkim, and the development of “Cybersmart Citizen” and “Stay Smart online” campaigns catering to different sections of the society. The targeted segments would include general public (SHGs (self-help groups)/ NGOs/ CSCs (common service centers)/ VLEs (village level entrepreneurs)/ ASHA workers etc.), students, undergraduate student, young professionals, including elderly citizens, government employees and SMEs.

#### 6.4.8 New projects initiated

During the year 2025-26, R&D efforts were continued and strengthened. New projects have been initiated which includes:

- **Privacy Preserving Data Processing And Exchange for Sensitive Data in the National Digital Public Infrastructure**

This project is being jointly implemented by 1) Centre of Data for Public Good (CDPG) within Foundation for Science Innovation and Development (FSID) at Indian Institute of Science (IISc), (2) Department of Computational and Data Sciences (CDS), IISc, (3) Indian Institute of Technology, Bombay (IIT-B), (4) International Institute of Information Technology, Bangalore (IIIT-B), (5) Centre for Development of Advanced Computing (CDAC) – Bangalore, (6) Centre for Development of Advanced Computing (CDAC) – Hyderabad. The project includes development of an open-source platform featuring a Secure Compute Layer based on TEE and/or SMPC, supporting processing blocks such as de-identification pipelines with Differential Privacy, collaborative learning, federated ML, and secure inferencing; a control plane implementing policy-based consent mechanisms and discovery APIs; and complementary tools essential for end-to-end de-identification, including DPIA and privacy threat modelling. It also covers applied research in privacy- and security-enhancing technologies by exploring and prototyping components like homomorphic encryption (SHE/FHE), federated learning under heterogeneous constraints, security-by-design approaches, differentially private ML, and secure API analytics, along with enhancing these components to improve real-world performance. Further, the initiative includes identifying use cases, data providers, and development partners to implement POCs and scaling successful pilots across domains such as healthcare, cybersecurity, agriculture, and traffic. Additionally, it involves hosting international conferences on data security and privacy, bringing together academia, industry, startups, researchers, students, and government stakeholders to discuss theoretical and practical advancements in the field.

- **A Post-Quantum Secure ZKP-based Authentication Protocol for Connected and Autonomous Vehicles**

This project is being jointly implemented by IIT Roorkee and IIT Guwahati. The project aims to develop a real-time hardware testbed prototype of a Post-Quantum Authentication (PQA) protocol, incorporating RSUs (Road Side Units) and robotic connected and autonomous vehicles (with TRL 5-6). The protocol will be tested for connected and autonomous vehicles use cases. However, it is not limited to such applications and can be broadly utilized as a secure post-quantum authentication protocol between any two-edge, computing or communicating devices.

- **SARTHI: Securing Accelerators using Logic Obfuscated Hardware Authentication**

This project is being implemented by CSRI, CEERI Pilani, Rajasthan. The Project aim to advance cybersecurity through research and development across multiple fronts; designing robust cryptographic algorithms modeling and implementing authenticated computing and authenticated data-encryption schemes developing end-to-end encryption solutions for secure data transmission and storage and exploring logic obfuscation techniques for intellectual property protection. The project also includes FPGA prototyping and rigorous testing of proposed designs, together with performance measurement and in-depth security analysis to validate resilience and practicality in real-world deployments. As part of the MeitY-sponsored SARTHI project, significant progress has

been achieved at CSIR-CEERI Pilani with the successful development and delivery of a custom RTL-based FPGA implementation of the NIST-standard AES-256 encryption core. The compact 8-bit design supports 128-bit data and 256-bit key inputs, achieving an operating speed of 80 Mbps suitable for low-bandwidth secure communication links. On 26 November 2025, the AES-256 FPGA prototype was formally handed over to the Military College of Telecommunications Engineering (MCTE), Mhow, during the Military-Civilian Seminar organized by MCTE, marking a key milestone in the project's progress toward indigenous cryptographic hardware development.

- **Development of Contextual Event Analytics framework to Enhance Security Operations Efficiency through Effective Alert Management System in Next Gen SIEM Solution over a period of 24 months being implemented by CDAC-Mohali**

The project aims to develop a Contextual Event Analytics Framework to enhance the efficiency of Security Operations by improving the alert management capabilities of the existing indigenous Security Information and Event Management (SIEM) solution (CDACSIEM). The focus is on addressing challenges of excessive and redundant alerts through AI-driven techniques for adaptive detection, dynamic categorization, and intelligent correlation of heterogeneous logs. CI informed that the developed framework will be seamlessly integrated with the SIEM, enabling reduction in alerts, improved prioritization of incidents, and faster response times. CI informed that the project will transform the current system into a next-generation SIEM solution that strengthens cybersecurity operations with enhanced automation, contextual awareness, and actionable insights.

- **Design & Development of Advanced Mobile Security & Analysis Solutions**

The Project is being implemented by C-DAC Hyderabad, NITK Surathkal, MNIT Jaipur, NIT Raipur and Anna University Chennai for a duration of 3 years.

The project aims to investigate the mobile security threat landscape and research on evolving new tools and techniques for Protection & Analysis in the mobile ecosystem. The project addresses security challenges across the layers of mobile stack including Application Layer, Mobile OS Layer and Platform layer.

## 6.5 Indian Computer Emergency Response Team (CERT-In)

The Indian Computer Emergency Response Team (CERT-In) is established in January 2004 under Ministry of Electronics and Information Technology, Government of India. CERT-In has been designated under Section 70B of the Information Technology Act, 2000 to serve as the national agency for cyber incident response and to perform the following functions in the area of cyber security:

- Collection, analysis and dissemination of information on cyber security incidents
- Forecast and alerts of cyber security incidents
- Emergency measures for handling cyber security incidents
- Coordination of cyber security incident response activities
- Issue guidelines, advisories, vulnerability notes and white papers relating to information security practices, procedures, prevention, response and reporting of cyber incidents
- Such other functions relating to cyber security as may be prescribed.

CERT-In creates awareness on cyber security issues through dissemination of information on its websites (<https://www.cert-in.org.in> and <https://www.csk.gov.in>) and operates 24x7 incident response Help Desk. CERT-In provides Incident Prevention and Response services as well as Security Quality Management Services.

The activities carried out by CERT-In during January 2025 to December 2025 comprised of the following:

Activities	Numbers (January 2025 to December 2025)
Incidents handled	29,44,248
Security Alerts	1530
Advisories	65
Vulnerability Notes	390
International cyber security drills/exercises	05
Domestic Cyber security drills/exercises	18
Training Programs & participants	32 Programs (Trained 20,799 participants)
Awareness sessions	78 Sessions (covers 91,265 participants)

CERT-In has issued 65 Advisories, 390 Vulnerability Notes and 1530 Security alerts during the year 2025.

### 6.5.1 Cyber Security Assurance

Under Security Assurance Framework, Indian Computer Emergency Response Team (CERT-In) has created a panel of 'Information security auditing organizations' for auditing, including vulnerability assessment and penetration testing of computer systems, networks & applications of various organizations of the Government, critical infrastructure organizations and those in other sectors of Indian economy. In the year 2025, there are 234 information security auditing organizations empanelled by CERT-In, on the basis of stringent qualifying criteria, to carry out information security audit, including the vulnerability assessment and penetration test of the networked infrastructure of government and critical sector organizations. This list of CERT-In empanelled auditing organizations is being consulted frequently by the entities in Government and critical sectors for their auditing requirements. CERT-In also completed technical skills re-verification of already empanelled auditing organizations.

### 6.5.2 Cyber Crisis Management Plan

CERT-In, MeitY has formulated Cyber Crisis Management Plan (CCMP) for countering cyber-attacks and cyber terrorism for implementation by all Ministries/Departments of Central Government, State Governments/UTs and organizations under their administrative control. Along with the CCMP, CERT-In has developed Guidance Framework for CCMP which may be used as a template by various entities including Central Government Ministries/ Departments/ States/UTs and entities under their administrative control to prepare & implement their own CCMP. CCMP outlines a framework for dealing with cyber related incidents for a coordinated, multi-disciplinary and broad-based approach for rapid identification, information exchange, swift response and remedial actions to mitigate and recover from malicious cyber incidents. CERT-In has conducted 20 workshops during the year 2025 to appraise various organizations under the Central Ministries/States/UTs about the implementation of CCMP and cybersecurity best practices and all necessary assistance is being provided to them with regard to implementation of CCMP. Till date, 222 CCMP enabling workshops have been conducted.

### 6.5.3 Cyber Security Exercises

Cybersecurity exercise is an effective tool to help entities in assessing cybersecurity preparedness to counter cyber-threats and building cyber-resiliency. CERT-In regularly conduct Cyber Security Exercises for critical sector organizations.

## Domestic Multi-Sector Exercises & Drills

Till date, CERT-In has conducted 126 Cybersecurity exercises of different complexities, including table top exercises, with participation from about 1651 organizations covering various sectors of Indian economy from Government/Public/Private i.e. Defence, Paramilitary forces, Space, Atomic Energy, Telecommunications (ISPs), Finance, Power, Oil & Natural Gas, Transportation (Railways & Civil Aviation), IT/ ITeS sectors and State Data Centres.

- **Cyber Rakshan**

CERT-In successfully conducted the national-level “Cyber Rakshan” Table Top Exercise (TTX) on 08 May 2025, focusing on crisis response across the BFSI, Power, Transport, Telecom, Central Government Ministries/ Departments, and State sectors. 1200 officials have participated in the exercise emphasizing on “Securing Digital Bharat: Responding to Crisis,” by enhancing coordinated cyber readiness at scale.

- **Cybersecurity Exercise for Government of J & K Administration**

CERT-In successfully conducted a sectoral CCMP Workshop & Cybersecurity Table Top Exercise (TTX) for the Government of Jammu & Kashmir Administration during 16 –17 June 2025 at SKICC, Srinagar. 250 participants from various departments attended the event. The objective of this event was to strengthen departmental preparedness and transition towards a proactive cyber resilience framework.

- **Cyber Bharat Setu – Bhopal, Madhya Pradesh**

CERT-In, successfully conducted a two-day cybersecurity exercise “Cyber Bharat-Setu” in Bhopal, for Madhya Pradesh. The exercise was held under the theme “Bridging States, Securing India”. The need for inter-state collaboration and technological empowerment for national cybersecurity, sharing detailed insights on cybersecurity roadmaps, incident response, information security governance, CCSP audits, and emerging threats were the key agenda of this program.

- **Cyber Bharat Setu – Agartala, Tripura**

CERT-In, successfully conducted a two-day cybersecurity exercise “Cyber Bharat-Setu” in Agartala, for the state Tripura during 11-12 November 2025. Secretary, MeitY inaugurated the workshop with the theme “Bridging States, Securing India”, focused on enhancing awareness, preparedness, and coordinated response to cyber threats. More than 250 participants from various departments of Tripura state have participated in the event.

- **Cyber Bharat Setu – Dehradun, Uttarakhand**

CERT-In, successfully conducted a two-day cybersecurity exercise “Cyber Bharat-Setu” in Dehradun, for the state Uttarakhand. The exercise was held under the theme “Bridging States, Securing India”. The need for inter-state collaboration and technological empowerment for national cybersecurity, sharing detailed insights on cybersecurity roadmaps, incident response, information security governance, CCSP audits, and emerging threats were the key agenda of this program. More than 200 participants from various departments of Uttarakhand state have joined in the event.

## Sectoral Cyber Security Drills

- **Cybersecurity Workshop, Exercise & Drill for Ministry of Railways**

CERT-In successfully conducted a full-day Operational and Technical Cybersecurity Workshop, Exercise & Drill for the Ministry of Railways and related entities on 25 April 2025 at the CERT-In office in New Delhi, with participation of 53 officials from 28 organizations. The event offered actionable insights and practical takeaways to enhance cybersecurity readiness and incident response capabilities across the transport sector.

- **CERT-In & SEBI 5th Operational Table Top Exercise**

CERT-In, in collaboration with SEBI, successfully conducted the fifth sectoral Operational Table Top Exercise (TTX) for BFSI entities on 23 July 2025. 30 participants from 17 organizations took part in the exercise. The agenda of this exercise emphasized proactive defence, incident preparedness, and third-party risk governance” to enhance sector-wide cyber resilience.

#### International Cyber Security Exercises

- **Global Inter-Governmental Points of Contact (POC) Directory – Simulation Exercise [Asia-Pacific 1]**

CERT-In participated in the Global Inter-Governmental POC Directory Simulation Exercise for the Asia-Pacific region on 17 March 2025. The simulation enabled POC from 20 countries to practice operational and diplomatic coordination workflows while strengthening their understanding the use of technical and diplomatic Point of Contact directory and their roles in Cybersecurity cooperation.

- **APCERT Drill 2025**

CERT-In contributed and participated in the APCERT Drill 2025 held on 29 July 2025. The theme of the drill was “When Ransomware Meets Generative AI”. The exercise witnessed participation from 22 CERTs across 18 APCERT economies and 7 CSIRTs from OIC-CERT and AfricaCERT, fostering international collaboration and preparedness against AI-driven ransomware threats.

- **ACID Drill 2025**

CERT-In participated in the ACID Drill 2025 conducted during 21–22 October 2025, focusing on “Securing Network Devices at the Edge” along with a parallel TTX on “Cross-Border Threats to Critical Information Infrastructure.” The exercise strengthened international readiness by testing response approaches to evolve multi-jurisdictional cyber threats.

- **Second BRICS Cyber Drill**

CERT-In participated in the 2nd BRICS Cyber Drill held during 29 – 30 October 2025, focusing on the theme “Central Bank Digital Currency (CBDC) Node Compromise – Systematic Implications”. The two-day drill enhanced cross-nation coordination and preparedness for financial-sector cyber incidents with systemic impact.

- **Quantum Dawn VIII**

CERT-In participated in the global Quantum Dawn VIII international cybersecurity exercise held during 04 – 06 November 2025, organized by the Securities Industry and Financial Markets Association (SIFMA). The three-day simulation engaged over 900 participants from more than 100 CSIRTs and institutions worldwide, including financial firms, central banks, regulators, and law enforcement. The exercise tested the resilience of core financial operations through multi-faceted crisis scenarios and strengthened global crisis management, recovery planning, and cross-sector information-sharing mechanisms. Participants collaboratively assessed impacts and response strategies, enhancing coordinated decision-making and regulatory preparedness for large-scale cyber events

#### 6.5.4 International Cooperation and Collaboration

##### Memorandum of Understanding (MoU)/Memorandum of Cooperation (MoC)

Strengthening cooperation with all stakeholders to effectively deal with cyber security issues has been one of the main focus areas of the Government. This aspect is being dealt with by way of security cooperation arrangements in the form of Memorandum of Understanding (MoU)/Memorandum of Cooperation (MoC)/Program of Cooperation (PoC) between Indian Computer Emergency Response Team (CERT-In) and its overseas counterpart agencies that are willing to work together and share information in a timely manner for preventing cyber-attacks as well as collaborating for providing swift response to cyber security incidents.

- **International Bilateral Cooperation**

Currently, the Indian Computer Emergency Response Team (CERT-In) has 6 active Bilateral agreements in the form of MoU/MoC/PoC in the area of cyber security with counterpart agencies in Bangladesh, Egypt, Estonia, Japan, Russian Federation and United Kingdom.

- **Industry and Academia Collaboration**

CERT-In is regularly coordinating with leading service providers and product vendors within and outside the country to obtain advance information on latest cyber threats and attack trends and devise appropriate proactive and preventive measures. To deal with the complex, sophisticated cyber-attacks, CERT-In partners with cyber security organizations from industry for collaboration in the area of cyber security with BITS Pilani, CISCO India, CloudSEK, Google India, Quick Heal, Information Sharing and Analysis Centre (ISAC), Mastercard India Services Private Limited, Microsoft, Micro World Technologies (eScan), National Institute of Electronics & Information Technology (NIELIT), K7 Computing, Kaspersky, Skills DA, Redinent Innovations, Fortinet Inc, Cyber Buddha Techno Legal Pvt. Ltd, Satellite Communications Industry Association (SIA) and Lisianthus Pvt Ltd. .

### **Multilateral forums**

- CERT-In is an Operational Member of Asia Pacific Computer Emergency Response Teams (APCERT). APCERT is a regional forum to ensure Internet security in Asia Pacific region.
- CERT-In is a full member of Forum of Incident Response and Security Teams (FIRST). FIRST is a global forum for cyber security teams around the globe.
- CERT-In is Accredited Member of Task Force for Computer Security Incident Response Teams / Trusted Introducer (TF-CSIRT/TI) from 13<sup>th</sup> September 2022. TI-CSIRT was established by the European CERT community in 2000 to address common needs and build a service infrastructure providing vital support for all security and incident response teams.
- CERT-In is an associate partner in Charter of Trust (CoT) global forum. The Associated Partner Forum (APF) of CoT brings together regulators, research institutes, universities, and think tanks with the CoT's industry partners to build a trusted network committed to creating a strong digital security environment across the global economy.
- CERT-In leverages these forums for timely resolution of cross border related cyber security incidents affecting Indian cyber space.

### **Technical Working Groups**

CERT-In is member of various other working groups under APCERT such as Information sharing working group, Drill working group, Malware Mitigation working group, Tsubame working group and Training Working Group.

### **Global Recognition and Contribution**

- CERT-In's initiative to strengthen cybersecurity resilience in Indian cooperative banks has been featured in the Global Cybersecurity Outlook 2025 report by the World Economic Forum (WEF). The report featured a case study lauding the Indian Computer Emergency Response Team (CERT-In) for its ground breaking initiative to enhance cybersecurity resilience.
- World Economic Forum's Global Communications Group released a video on Cyber Swachhta Kendra of CERT-In on January 18, 2025 before the Annual Meeting in Davos which was held on January 20, 2025.
- In April 2025, CERT-In was able to contribute to the "Cyber Resilience Compass" paper published by the World Economic Forum and the University of Oxford. The report outlines 7 critical domains for strengthening resilience drawn from the front-line practices of leading organizations globally.

- The Indian Computer Emergency Response Team (CERT-In) is one of the international partners to co-sign the joint high-level risk analysis report on Artificial Intelligence (AI) entitled “Building trust in AI through a cyber-risk-based approach,” published by the National Cybersecurity Agency for France (ANSSI) in February 2025. The report advocates for a risk-based approach to support trusted AI systems and secure AI value chains and calls for discussions on AI-related cyber risks and how to mitigate them to foster trusted AI development.
- In December 2025, the World Economic Forum and the Institute for Security and Technology published a white paper with insights on CERT-In leveraged AI and situational awareness systems to analyse over 9,800 billion DNS queries, identifying 128 million phishing domains from 2.2 billion malicious queries in 2024.
- CERT-In’s initiative to push organizations for post Quantum cyber readiness was also presented in the APCERT AGM and Conference 2025 held in Sydney Australia during 25-27 November 2025.

### 6.5.5 CVE Numbering Authority (CNA)

CERT-In has been undertaking responsible vulnerability disclosure and coordination for vulnerabilities reported to CERT-In since its inception. To move a step further in the direction to strengthen trust in “Make in India” as well as to nurture responsible vulnerability research in the country, CERT-In has partnered with the CVE Program, MITRE Corporation, USA. In this regard, CERT-In has been authorized by the CVE Program, as a CVE Numbering Authority (CNA) for vulnerabilities impacting all products designed, developed and manufactured in India since October 2021.

CNAs are organizations responsible for the regular assignment of CVE IDs to vulnerabilities, and for creating and publishing information about the vulnerability in the associated CVE Records within their own specific scopes of coverage. In year 2025, 29 CVE IDs have been assigned and published by CERT-In.

### 6.5.6 Sectoral and State CSIRTs

Under Sub-section (IV), clause (e) of the National Cyber Security Policy, 2013 proposed to create mechanisms for Security threat early warning, vulnerability management and response to security threats, CERT-In functions as the umbrella organization in enabling creation and operationalization of Sectoral and State Computer Security Incident Response Teams (CSIRTs) as well as facilitating communication and coordination actions in dealing with cyber crisis situations. CERT-In is issuing the necessary guidelines for setting up of sectoral CSIRTs and state CSIRTs.

#### 6.5.6.1 State CSIRTs

- West Bengal State CSIRT is operational from 8 July 2019 and it was notified through Gazette notification at State level.
- The Madhya Pradesh Computer Emergency Response Team (MP-CERT) is operational under the Department of Science and Technology, Government of Madhya Pradesh since December 14, 2022.

#### 6.5.6.2 Sectoral CSIRTs

##### CSIRT-Fin

CSIRT-Fin under CERT-In has been assigned the responsibility for coordinating and supporting the response to a computer security event or incident within the financial sector constituency. CSIRT-Fin is the incident response force which focuses on mitigation processes, providing on-site awareness, expertise, and recovery oversight.

The snapshot of activities performed by CSIRT-Fin this year, is as follows:

- Handling of security incidents in collaboration with CERT-In which included security incidents related to vulnerable services, botnets, open services and phishing incidents. Entities have also been on boarded to CERT-In’s Cyber

Swachhta Kendra (CSK) for providing automated feeds regarding malware infections, botnets and vulnerable services

- Issuing of vulnerability notes and virus alerts along with CERT-In.
- Tailored threat intelligence alerts for proactive measures were sent to financial sector constituency and entities have been on boarded on CERT-In's automated threat intelligence platform.

### CSIRT-Power

CERT-In has actively supported and guided the establishment and operationalization of CSIRT-Power under the Ministry of Power. CERT-In has extended strategic, technical, and operational support to enhance cybersecurity resilience in power sector. CSIRT-Power became operationalised and notified on 23 September 2024 to serve as the responsible agency for responding to and preventing cybersecurity incidents within the power sector in coordination with CERT-In. CERT-In is sending out fortnightly report on vulnerable services and botnet infections through its Cyber Swachhta Kendra (Botnet Cleaning and Malware Analysis Centre) to sectoral CSIRTs, Ministry of Power and other stakeholders in Power sector.

### CSIRT Telecom

Department of Telecommunication (DoT) has notified Telecom CSIRT (T-CSIRT) for telecom sector on 28 June 2023.

### 6.5.7 Cyber Swachhta Kendra (Botnet Cleaning and Malware Analysis Centre)

- Cyber Swachhta Kendra (CSK) - The Botnet Cleaning and Malware Analysis Centre has been setup with an eye to create a secure cyber space by detecting botnet infections in India and to notify, enable cleaning and securing systems of end users so as to prevent further infections. CSK is covering about 98% of Indian internet users as well as 1427 organizations across sectors. The Centre is working with Energy, Finance, Healthcare, Infrastructure, Transport, "Industries and Manufacturing", "IT & ITeS", Government, Agriculture and Academia Sector organizations to detect malware infections in their networks and enable remedial actions.
- Cyber Swachhta Kendra aims to secure India's digital IT Infrastructure by creating a dedicated mechanism for providing timely information about Botnet/Malware threats to the victim organization/user and suggesting remedial actions to be taken by the concerned entity. CSK is playing a very proactive and pivotal role in a continuously evolving cybersecurity environment through identifying new botnet/malware, understanding their threat level and subsequent Information dissemination to organizations with suggestive remedial actions.
- In order to reach out larger audiences in the country, the website of Cyber Swachhta Kendra is available in Hindi language and a new domain "[www.सीएसके.सरकार.भारत](http://www.सीएसके.सरकार.भारत)" was created. Hindi website of CSK received positive response and became very popular among citizens. CSK also started notifying end users about botnet/malware infection in their digital devices via Internet Service Providers (ISP) in Hindi as well as English language. This activity was also appreciated by users.
- In the year 2025, over 300 botnet/malware family were tracked and reported to collaborating ISPs/organizations. The type of Malware/Botnet infections include Trojans, IoT bots, Ransomware, Crypto currency miners, POS Malware, Worm, Botnets, Adware, Exploit kit etc. Moreover, systems with vulnerable services that could be exploited to carry out cyber-attacks were also reported to various critical sector organizations. The vulnerabilities could also have severe impact such as information disclosure, launch DDoS attacks, unauthorized access etc. CSK suggests about solutions/ patching of the vulnerabilities.
- During 1 - 15 February 2025, CSK celebrated "Cyber Swacchta Pakhwada" to create cyber security awareness among internet users across the country. CSK coordinated with ISPs, Anti-Virus companies to reach out and

inform end users of internet about malware attacks, implications and safe guard their interest in cyber space. Around 3.16 lakh Free Bot Removal Tool downloads were observed during this period (1-28 February 2025). During the National Cyber Security Awareness month of October 2025, CSK reached out to end users to promote cyber hygiene and awareness in coordination with ISPs. Around 2.72 lakh downloads were observed during this period (1-31 October 2025).

- CSK is committed to enable users getting their digital devices secure against any cyber infection. CSK also strives to collaborate with Indian entities/ cyber security companies to come up with good security solutions/ AVs. CSK currently has collaboration with three Free Bot Removal Tools (FBRTs) namely Escan, K7 and QuickHeal to citizens through its portal/website. CSK is now providing FBRT for Windows as well as for Android platform. Number of downloads of Free Bot Removal Tools by users is 89,55,428. Also, CSK has collaborated with CDAC Hyderabad to provide a Free Android Security solution - mKavach via its website. The FBRTs are regularly updated with latest malware signature of recent botnet/ malware so that citizens can be safe against evolving cyber malware.

### 6.5.8 Cyber Forensics Lab

The Cyber Forensics Laboratory of CERT-In is a notified Lab under the scheme of Examiner of Electronic Evidence in exercise of the powers conferred under section 79A of the Information Technology (IT) Act, 2000 in Computer Forensics and Mobile Device Forensics as its scope.

Cyber Forensics Lab of CERT-In is equipped with the state-of-the-art equipment and tools to carry out data retrieval, processing and analysis of the raw data extracted from the digital data storage, mobile devices, cloud service providers, Internet of Things (IoT) devices, Drones, Digital Video Recorders (DVRs) and Network Video Recorders (NVRs) using sound digital forensic techniques. The Lab also has the capabilities of unlocking/bypassing complex passwords of high-end devices and extracting data from hidden folders.

The primary task of the Cyber Forensics Lab is to assist the Incident Response (IR) team of CERT-In on occurrence of a cyber-incident and extend digital forensic support to carry out further investigation. In addition, the Cyber Forensics Lab assists different Law Enforcement Agencies (LEAs), Intelligence Agencies and State Police departments in digital forensic data retrieval and analysis which is being extensively used in investigation of the cases of terrorism, anti-national activities, narcotics, trafficking etc, that involves unlocking and bypassing of security features of high-end digital exhibits in a forensically sound manner such that the report can be presented in the Court of Law.

### 6.5.9 CERT-In Threat Intelligence eXchange - Proactive Threat Intelligence Sharing Platform

CERT-In established its automated Cyber Threat Intelligence Sharing Platform [CTIS] in 2018 for facilitating bidirectional sharing of operational, strategic, enriched tactical threat intelligence to various counterparts and stakeholders. This initiative is helping Indian stakeholders to enhance the effectiveness of security and IT teams in reducing exposure by attempt to uncover unknown threats and informing better, faster decisions. The platform collects, correlates, enriches, contextualizes, analyses, integrates, tags with Traffic Light Protocol (TLP) and pushes to the partners in near real time. The shared data can be consumed by the recipients into their automated workflows so as to streamline the threat detection, management, analysis, and defensive process and track it through to completion by leveraging its powerful API integrations with supporting SIEMs, firewalls, and other endpoint protection solutions.

CERT-In envisages that implementing threat intelligence profoundly elevates Government/Critical organization's security posture, enabling the respective security team to understand and effectively predict the cyber threats that imperil their organization's key assets. Empowering organizations to anticipate who may attack next, and how, allows security teams to focus on prioritizing resources so they can respond effectively to future cyber-attacks.

Threat intelligence exchange activities at CERT-In are conducted through multiple channels to ensure comprehensive coverage and timely dissemination. Traditional methods such as emails and official letters are used to deliver advisories, alerts, and contextual intelligence to organizations that may not be directly connected to automated systems.

In parallel, CERT-In operates its automated Cyber Threat Exchange platform, which collects, enriches, tags, and distributes intelligence in near real time, enabling seamless integration with SIEMs, TIPs, and incident management tools. The shared data is consumed by the recipients to streamline the threat detection, management, analysis, and defensive processes to enhance cyber security at entity/organization level.

This multi-channel approach creates a resilient ecosystem for intelligence sharing. Formal communications via email and letters guarantee that critical updates reach all stakeholders, while platform-based exchanges provide structured, contextualized, and actionable threat data for immediate operational use. Together, these mechanisms empower organizations to proactively detect malicious infrastructure, strengthen incident response, and enhance collective cyber defense across sectors. Additionally, CERT-In continuously monitors dark web ecosystems, messaging platforms and gathers early indicators of malicious activity, stolen data, and adversary tactics. This intelligence is enriched, correlated, and shared with stakeholders to strengthen proactive defense, incident response, and national cyber resilience.

### 6.5.10 Cyber Security Trainings

As part of its mandate, CERT-In is regularly carrying out various activities for development of cyber security capacities, skill building, awareness and citizen sensitization with respect to cyber-attacks and cyber frauds. In order to create security awareness within the Government, Public and Private Sector organizations, CERT-In regularly conducts trainings / workshops to train officials of Government, Public and Private sector organizations across all sectors and citizens on focused topics of Cyber Security. The training/workshop programs focus on technical topics with technology presentations & demonstration/Hands-on sessions for technical cyber community.

#### Technical trainings

In the year 2025, CERT-In has conducted 32 trainings on various specialized topics of cyber security. About 20,799 Officers including system/Network Administrators, Database Administrators, Application developers, IT Managers, Chief Information Security Officers (CISOs)/ Chief information officers (CIOs), and IT Security professional have been trained.

#### (a) Internship

CERT-In is also one of the active participating institutes offering Internship under the Work Based Learning Programme of MeitY to provide stipend-based Internship for candidates belonging to SC/ST, Women and EWS Category.

#### Special Trainings

- (i) To promote the importance of post quantum cyber readiness, CERT-In organized a one-day training programme at CERT-In during October 2025. More than 80 participants from Central/State Government ministries, PSUs participated in the event.
- (ii) CERT-In contributed to the 2-day Cyber Security Workshop & Table Top eXercise (TTX) conducted by NeGD in collaboration with CERT-In. 100+ participants from 27 states, 38 ministries attended the event which focused on State CSIRT establishment, CERT-In guidelines, SOC, CCMP, TTX and Cyber laws & Quantum Risks.

### Certificate Courses

- (i) A comprehensive online 8-week program by CERT-In and Center for Research Excellence in National Security (CRENS) at BITS Pilani was launched in July 2025. The course aims to equip mid to senior-level professionals with critical skills to address the evolving cyber threat landscape. The first batch witnessed more than 90 registrations from various government departments, armed forces, defence public sectors, industries, and police.
- (ii) CERT-In launched a free online self-paced learning “Cyber security Foundations course” in collaboration with Microsoft. The course comprises of two levels. Level 1 module will be focussing on the fundamentals of cybersecurity and protecting against cyberthreats. Participants will learn about cybersecurity concepts and ways to protect themselves and their business from cyberattacks. Level 2 module will cover the four main phases of threat modeling, data-flow diagrams, and threat modeling framework. On successful completion of the modules, participants will receive a certificate of completion and a digital badge to showcase the online achievement.
- (iii) Launched in September 2024, CERT-In and SISA are offering the Certified Security Professional in Artificial Intelligence (CSPAIA) program. The course is the world’s first AI cybersecurity certification approved by the ANSI National Accreditation Board (ANAB) by meeting the ISO/IEC 17024 standard. The program aims to address the growing need for Secure and Responsible AI integration into business applications and processes. The certification program shows the commitment of the Government of India to enhance the capacity building of skilled manpower in AI.

### 6.5.11 Cyber Security Awareness

CERT-In is carrying out various activities and campaign for creating cyber security awareness and sensitizing internet users for safeguarding from various cyber threats, frauds and crimes. CERT-In is observing Cyber Security Awareness Month during October of every year, Safer Internet Day on 1st Tuesday of February Month every year, Swachhta Pakhwada from 1 to 15 February of every year and Cyber Jagrookta Diwas (CJD) on 1<sup>st</sup> Wednesday of every month by organising various events and activities for citizens as well as the technical cyber community in India. CERT-In officials provide Cyber security and Cybercrime frauds awareness sessions to different Ministries, Government Departments, Educational institutions and Industry across the country.

October Month is observed every year as Cyber Security Awareness Month globally as well as in India. CERT-In observed the October Month 2025 as National Cyber Security Awareness Month (NCSAM) with the theme #CyberJagritBharat”. As part of NCSAM October 2025, CERT-In has carried various activities, awareness campaigns in collaboration with partners and government agencies throughout the month of October 2025. Total outreach during the NCSAM 2025 is 35,85,81,238.

#### Awareness Posters/Videos

CERT-In created its own awareness content in various forms such as one liner quick safety tips, detailed posters with best practices, infographics in 9 Indian languages, visual meme posters, AI videos, awareness booklets for dissemination on official websites and social media handles. A total of 351 such posters/videos have been made and published for spreading awareness among digital nagriks and enterprises during NCSAM October 2025.

#### Awareness Sessions

During NCSAM October 2025, CERT-In conducted 43 awareness sessions for different Government ministries/ departments and other sectors in collaboration with different organizations covering 76,030 participants. In 2025, CERT-In has conducted 78 awareness sessions covering 91,265 participants (including NCSAM 2025).

**Awareness Booklets**

**(i) NCSAM 2025**

During NCSAM 2025, CERT-In published a “Cyber Smart Kids: Suraksha Guide”, a cyber awareness booklet for children. CERT-In also published “Cyber Security Best Practices for Senior Citizens” booklet.

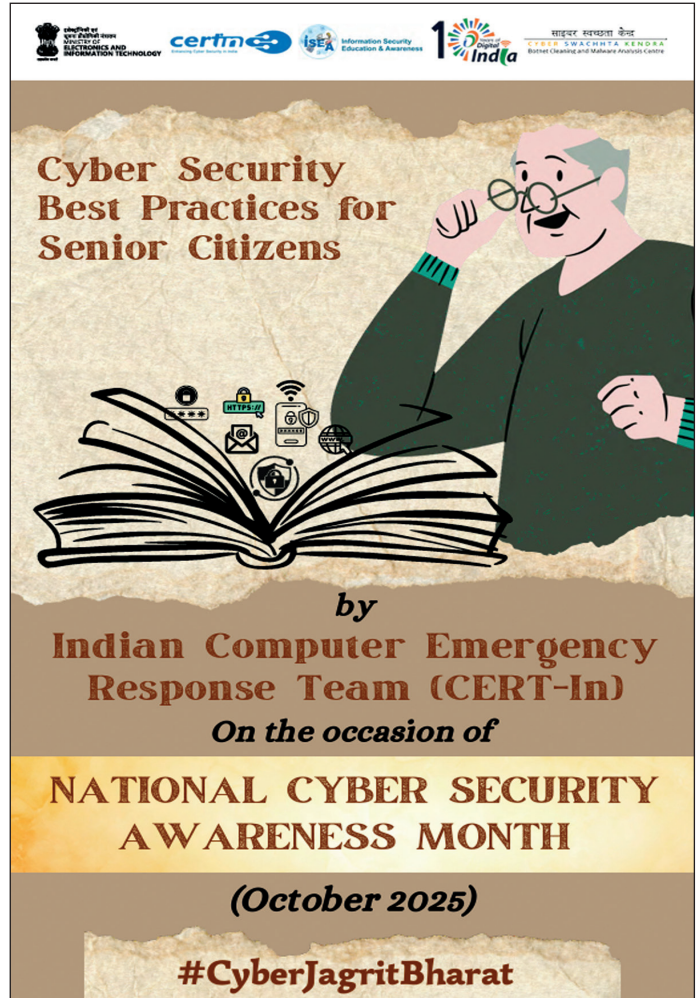

**(ii) Mahila Suraksha**

To educate women users on Cyber security best practices, CERT-In released the “Cyber Security Handbook for Mahila Suraksha” on the occasion of International Women’s day 2025. To ensure wider dissemination and outreach of the awareness booklet, the booklet was shared through websites of CERT-In, social media handles of CERT-In, MyGov and Transforming India. On International Women’s Day 2025, around 1600 women officials from 30 States and Union Territories took part in the CERT-In’s “Cybersecurity Awareness Sessions for Women Officials.”

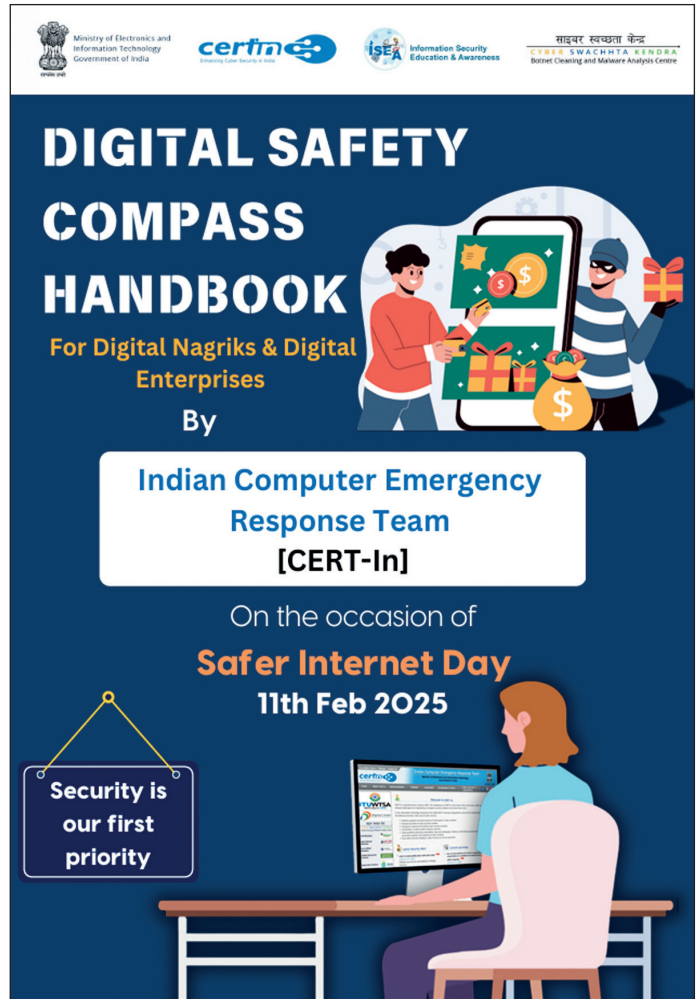
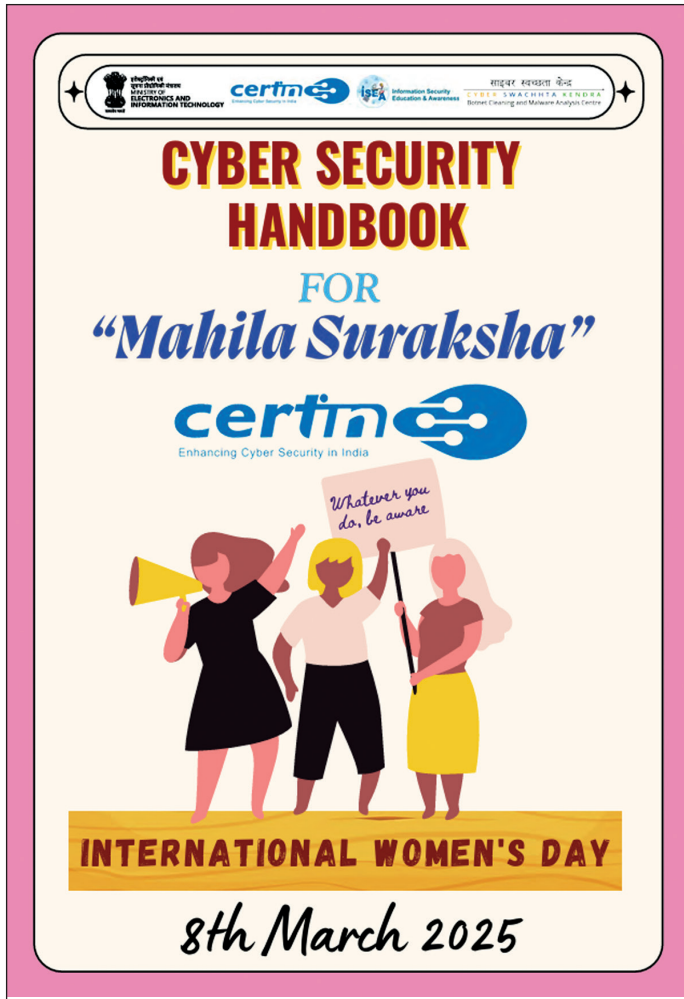

**(iii) Safer Internet Day**

CERT-In observed Safer Internet Day on 11 February 2025. CERT-In released an awareness booklet “Digital Safety compass Handbook”. The Booklet provided detailed information on modus operandi of different online threats and best practices to stay protected from such threats.

**Social Media Outreach**

CERT-In is regularly sharing safety and security tips and awareness posters, info-graphics and videos through its official websites and social media handles such as Facebook, X (Twitter), Instagram, YouTube and LinkedIn for sensitising internet users on cyber frauds and cybersecurity best practices. Information about cyber Security alerts, advisories, Vulnerability notes and other activities of CERT-In are also disseminated on regular basis through its social media handles.

**Cyber MUN**

CERT-In in collaboration with ISEA is organizing Cyber Model United Nations (MUN) events across the country. The event promotes cyber security adoption practices among the school children. CyberMUN events were held at Chennai, Bangalore, Delhi, Patna, Lucknow and Mumbai.

## Reels and Quiz

CERT-In in collaboration with Cyber Buddha Techno Legal Pvt Ltd. launched a quiz competition and reels competition under three different age group categories through MyGov platform during NCSAM 2025 to promote education and adoption of Cyber hygiene principles among students. The event received active participation across all age group categories.

### 6.5.12 Guidelines and Publications

**CERT-In published the following key guidelines and whitepapers in 2025.**

- (a) Cyber Security Guidelines for Smart City Infrastructure
- (b) Technical Guidelines on SBOM, QBOM, CBOM, AIBOM & HBOM
- (c) 15 Elemental Cyber Defense Controls for Micro, Small, and Medium Enterprises (MSMEs)
- (d) Comprehensive Cyber Security Audit Policy Guidelines
- (e) Digital Threat report for BFSI Sector
- (f) India Ransomware Report 2024
- (g) Whitepaper on “Transitioning to Quantum Cyber Readiness”
- (h) Whitepaper on “Good Practices for protecting Unmanned Aircraft Systems (UAS) against Cyber Security Threats”
- (i) Advisory on “Cybersecurity Threats and Best Practices for Satellite Communications”
- (j) Advisory on “Essential Measures for Industry for Safeguarding Business Operations against Cyber Security Threats”
- (k) Advisory on “Essential Measures for MSMEs for Safeguarding Business Operations against Cyber Security Threats”
- (l) Advisory on “Best Practices against vulnerabilities while using Generative AI solutions”

### 6.5.13 National Cyber Coordination Centre (NCCC)

CERT-In has operationalised the National Cyber Coordination Centre (NCCC) project with the objective to generate situational awareness of existing and potential cyber security threats and enable timely information sharing for proactive, preventive, and protective actions by individual entities. NCCC aims to create a structured system to facilitate coordination effort among stakeholders by sharing with them inputs in terms of information about threats/attacks and possible extent which in turn enables immediate remedial actions by the stakeholders. The project is facilitating various organizations and entities as well as major events in the country to mitigate cyber-attacks and cyber incidents on a near real time basis.

### 6.5.14 CERT-In Initiatives towards Security including Digital Payments

- CSIRT-Fin under CERT-In has been assigned the responsibility for coordinating and supporting the response to a computer security event or incident within the financial sector constituency. CSIRT-Fin is the incident response force which focuses on mitigation processes, providing on-site awareness, expertise, and recovery oversight.
- CERT-In has empanelled 231 Information Security Auditing organizations to carry out technical information security audit, including the vulnerability assessment and penetration testing of ICT infrastructure of government and critical sector organizations.

- All authorized entities/banks issuing PPIs in the country have been advised by CERT-In through RBI to carry out special audit by empaneled auditors of CERT-In on a priority basis.

## 6.6 Cyber Laws

MeitY is the custodian of three Acts, namely, the Information Technology Act, 2000 (IT Act), the Digital Personal Data Protection Act, 2023 (DPDP Act) and the Promotion and Regulation of Online Gaming Act, 2025 (PROG Act).

**Information Technology Act**— The IT Act was enacted on 17<sup>th</sup> October 2000 with a view to: (a) provide legal recognition of electronic records, (b) facilitate e-governance, e-transaction and e-commerce and (c) Deter computer-based crimes. The IT Act was amended in 2008 by incorporating provisions relating to protection of sensitive personal data, exemption from liability to intermediaries, protection of critical information infrastructure, penal provisions for new forms of cybercrime such as obscenity, sexually explicit materials, identity theft, cheating by personation, cyber terrorism, etc. The IT Act has been recently amended through the Jan Vishwas (Amendment of Provisions) Act, 2023 [*vide* Serial No. 32 and entries relating thereto in the Schedule] to amend certain provisions for decriminalization and rationalisation of offences to further enhance trust-based governance for ease of living and doing business. The Jan Vishwas (Amendment of Provisions) Act, 2023 may be accessed at the following link:

<https://egazette.gov.in/WriteReadData/2023/248047.pdf>

MeitY's 2022 amendment to the First Schedule of the IT Act significantly liberalised restrictions on digital documentation, allowing the e-execution of negotiable instruments and powers-of-attorney involving regulated financial entities, and removing the bar on digital conveyance of immovable property. This landmark reform enhances legal recognition of electronic records, promotes paperless transactions, and boosts e-commerce, fintech, PropTech, and digital real estate services. It is a major enabler of Digital India, Ease of Doing Business, and seamless digital governance.

MeitY regularly undertakes review of the existing rules under the IT Act with an attempt to overhaul them to address many present-day and emerging challenges in the cyberspace. In order to achieve the Government policy which is aimed at ensuring an Open, Safe & Trusted Internet and accountability of intermediaries including the social media intermediaries to users in India and to address other emerging issues relating to digital media entities, the Ministry of Electronics and IT (MeitY) in exercise of its powers under the Information Technology Act, 2000, has made and notified the Information Technology (Intermediary Guidelines and Digital Media Ethics Code) Rules, 2021 ("Intermediary Rules, 2021") on 25<sup>th</sup> February, 2021, which were subsequently amended on 28<sup>th</sup> October, 2022, 6<sup>th</sup> April, 2023 and 22<sup>nd</sup> October, 2025.

Based on the above amendment, the MeitY has established three Grievance Appellate Committees (GAC) on 27<sup>th</sup> January 2023. The GAC is an online dispute resolution mechanism. The entire appeal process, from filing to decision, is in digital mode. GAC functions as a grievance redressal forum overseeing the resolution of appeals related to social media platforms, including but not limited to Facebook, Instagram, WhatsApp, Twitter, LinkedIn, etc. The GAC deals with the appeals of users (Digital Nagriks) aggrieved by decisions of Grievance Officers of social media intermediaries and other intermediaries on complaints of users or victims against violation of the rules and any other matters pertaining to the computer resources made available by the intermediary. The Intermediary Rules, 2021 were further amended on 22.10.2025 to strengthen the framework of due diligence obligations of intermediaries under the IT Act, 2000. The latest amendments introduce additional safeguards under Rule 3(1)(d) to ensure that removal of unlawful content by intermediaries is carried out in a transparent, proportionate and accountable manner. The latest amended Intermediary Rules, 2021 may be accessed at the following link:

<https://www.meity.gov.in/static/uploads/2025/10/708f6a344c74249c2e1bbb6890342f80.pdf>

**Digital personal Data protection Act, 2023** has been enacted on 11<sup>th</sup> August 2023. The DPDP Act provides for the processing of digital personal data in a manner that recognizes both the rights of the individuals to protect their personal data and the need to process such personal data for lawful purposes and for matters connected therewith or incidental thereto. The URL of the notified Act is as under:

<https://www.meity.gov.in/static/uploads/2024/06/2bf1f0e9f04e6fb4f8fef35e82c42aa5.pdf>

On 14<sup>th</sup> November 2025, MeitY notified the Digital Personal Data Protection Rules 2025. This marks the full operationalisation of the Digital Personal Data Protection Act, 2023 (DPDP Act). The Rules establish a clear and practical framework to safeguard personal data in a rapidly expanding digital environment. They prioritise citizens' rights and promote responsible data use by organizations. By curbing unauthorized commercial exploitation of data, reducing digital harms and creating a secure space for innovation, the Rules will help strengthen India's trusted and resilient digital economy. They also introduce an eighteen-month phased timeline to enable smooth compliance.

To finalise the rules, MeitY invited public comments on the draft and conducted extensive consultations across the country. A wide range of participants took part in these discussions and submitted comments, including Startups, MSMEs, industry bodies, civil society groups, government departments and individual citizens. In total, 6,915 inputs were received. These contributions played a key role in shaping the final Rules.

With the notification of the Rules, India now has a practical and innovation-friendly system for data protection. It supports ease of understanding, encourages compliance and strengthens trust in the country's growing digital ecosystem.

The URL of the notified Rules is as under -

<https://www.meity.gov.in/documents/act-and-policies/digital-personal-data-protection-rules-2025-gDOxUjMtQWa?pageTitle=Digital-Personal-Data-Protection-Rules-2025>

**Promotion and regularization of online gaming Act, 2025**- The PROG Act has been enacted on 22<sup>nd</sup> August, 2025. The PROG Act aims to establish a uniform legal framework to regulate gaming, prohibit online money games, and promote and regulate online social games and e-sports. The PROGA act is available at Ministry's website at following URL:

<https://www.meity.gov.in/static/uploads/2025/08/4f673438a686e3fa81dd2d277b445f42.pdf>

MeitY has also released the Draft Promotion and Regulation of Online Gaming Rules, 2025 on its website on October 02, 2025, for public consultation. These Rules have been framed under Section 19 of the PROG Act, 2025.

# 7

## CHAPTER

# Skill India: Capacity Building

India's digital transformation agenda, anchored in the *Digital India* programme and aligned with the vision of *Viksit Bharat 2047*, places strong emphasis on building future-ready skills to power economic growth, technological self-reliance, and inclusive development. The country's focus areas include high-impact and emerging technologies such as Artificial Intelligence (AI), semiconductors and chip design, drones, additive manufacturing (3D printing), cybersecurity, cloud computing, Internet of Things (IoT), quantum technologies, and advanced electronics. These domains are critical for strengthening India's digital public infrastructure, boosting manufacturing and innovation ecosystems, enhancing national security, and positioning India as a global hub for deep-tech research, design, and deployment. Capacity building and skill development are therefore central enablers of Digital India initiatives, supporting both industry competitiveness and citizen-centric digital empowerment across urban and rural India.

Capacity Building and Skill Development Scheme is to build a robust talent pipeline and institutional ecosystem that supports high-tech industry growth, deep-tech innovation, and inclusive digital empowerment. The strategic objectives include: bridging advanced skill gaps with structured training/ experiential learning initiatives; indigenous localization of contents; democratizing access via digital platforms and regional hubs; promoting inclusive outreach to underserved groups and geographies; aligning curricula with industry needs and embedding competency-based assessments; fostering sustained multi-stakeholder partnerships; and strengthening research and innovation capacity through centres of excellence and incubation support, thereby significantly expanding skilled manpower and widening digital access. This is proposed to be achieved through skilling and capacity building initiatives to cover 1.5 crore learners by 2030, with a targeted focus on ensuring 25% representation from Tier-II and Tier-III cities, including synergy and alignment with the National Education Policy (NEP) 2020 and the National Skills Qualification Framework (NSQF).

The scheme is implemented through a coordinated, multi-tier approach to ensure scale, quality, and last mile reach. Policy alignment is ensured through collaboration with MSDE, MoE, and NITI Aayog, with regulatory oversight by NCVET, UGC, and AICTE. IIITs, NITs, and IISc anchor advanced training, applied research, curriculum development, and Centres of Excellence, supported by industry and academic content partners. Programme delivery is led by the Ministry's autonomous bodies, NIELIT, C-DAC, ERNET India, Media Lab Asia, STQC and NIC for digital enablement and quality assurance. Industry relevance is ensured through partnerships with Sector Skill Councils, particularly NASSCOM SSC, to align standards, curricula, and employability outcomes and at the ground level is carried out in collaboration with State Governments and their respective skill development agencies, Village level entrepreneurship of CSCs, training partners, academic institutions, and local stakeholders, enabling inclusive outreach across Tier-II and Tier-III cities and underserved regions.

The following schemes/programmes/projects in the domain of Electronics and ICT sector are under implementation:

### 7.1 Post Graduate and Doctorate Level

#### 7.1.1 Visvesvaraya PhD Scheme for Electronics & IT:

Details may be seen at Chapter 5.

## 7.2 Graduate level

### 7.2.1 Scheme of Financial Assistance for setting up of Electronics and ICT Academies

MeitY has approved the 'Electronics & ICT Academy Scheme - Phase-II' project on 26.04.2024. The project aims to train 1,35,000 faculty members/trainers in emerging technology areas. Phase - II would continue to focus on improving faculty quality in engineering colleges and technical institutions by leveraging the existing 7 E&ICT academies and extending to other institutions, particularly in tier-2/tier-3 areas. The project is being implemented through 14 implementing Agencies viz. (i) IIT Guwahati, Assam, (ii) IIT Roorkee, Uttarakhand, (iii) IIT, Kanpur, Uttar Pradesh, (iv) NIT Warangal, Telangana, (v) NIT Patna, Bihar, (vi) IIITDM Jabalpur, Madhya Pradesh, (vii) MNIT Jaipur, Rajasthan, (viii) ICT Academy, Tamil Nadu, (ix) NIELIT, Aurangabad, Maharashtra, (x) NIELIT, Calicut, Kerala, (xi) NIELIT, Gorakhpur, Uttar Pradesh, (xii) CDAC, Mohali, Punjab, (xiii) CDAC, Patna, Bihar; and, (xiv) CDAC, Hyderabad, Telangana.

By December 2025, 63,644 beneficiaries (Faculty: 57,081 - Student/ others: 6,563) have been trained under 943 Faculty Development Programmes (FDPs) by the implementing agencies in the Electronics and ICT domains.

## 7.3 Vocational Skill Development Level

### 7.3.1 Two Schemes for Skill Development in the ESDM sector have been implemented:

MeitY has approved two schemes on Skill Development in ESDM Sector viz. "Scheme for Financial Assistance to select States/UTs for Skill Development in Electronics System Design and Manufacturing (ESDM) sector" (Scheme-1) and "Skill Development in ESDM for Digital India" (Scheme-2) were approved (Scheme-1 was approved on 1st November 2013 and Scheme-2 was approved on 9th December 2014) to facilitate creation of an eco-system for development of ESDM Sector in the entire country. Cumulative skilling target of both the Schemes is 4,18,000 candidates (Scheme-1 target 90,000 and Scheme-2, target 3,28,000) through NSQF compliant courses at L1 to L5 levels (now at L3 to L5-L6).

The **Scheme-1** is being implemented by State Implementing Agencies (SIAs) in coordination with Training Partners affiliated through the Key Implementing Agencies (KIAs) i.e. ESSCI, TSSC, NIELIT and HSSC.

The **Scheme-2** is being implemented by the NIELIT-PMU in coordination with Training Partners and Key Implementing Agencies. Under the said Schemes 40% seats are reserved for SC/ST/EWS category candidates and 60% for General category candidates.

Under Scheme-1, out of a total target of 90,000, so far, a total of 1,08,624 candidates have been enrolled, 1,08,624 candidates have been trained, out of which, 86,945 have been certified and 39,524 candidates have been placed. Under Scheme-2, out of a total target of 3,28,000, so far, a total of 3,85,295 candidates have been enrolled and 3,85,295 candidates have been trained, out of which, 2,88,344 have been certified and 98,779 candidates have been placed. So far, under both the Schemes, a total of 4,93,919 candidates have been trained and 3,75,289 candidates have been certified and out of that a total of 1,38,275 candidates have been placed. The Scheme was concluded on 31.08.2025.

### 7.3.2 Efforts to generate greater participation of Industry through Sector Skill Councils-Electronics, Telecom, IT/ITeS

MeitY is actively associating and supporting the various skill development activities of the following Sector Skill Councils (SSCs) concerning the domains addressed by this Ministry:

- Electronics Sector Skill Council of India (ESSCI)
- Telecom Sector Skill Council (TSSC)
- IT-ITeS Sector Skill Council (NASSCOM)

The above Sector Skill Councils have taken up various courses for the skilling of candidates in their respective domains. The Ministry has also supported the development of new job roles/NOSs with ESSCI, TSSC, and IT/ITeS Sector Skill Council in the area of Electronics and IT.

## 7.4 Capacity Building in Niche Areas

### 7.4.1 Information Security Education and Awareness (ISEA) Project Phase-III:

MeitY has approved ISEA Project Phase-III on 16.10.2023 for 5 years. The ISEA Project Phase-III is aimed at development of human resources for safe, trusted, and secure cyberspace. The project envisaged generating 2.75 lakh human resources in the area of Information Security over a period of 5 years comprising 45,000 skilled & certified Cyber Security Professionals (i.e. CISOs, Deputy CISOs, Associate team of CISOs/Aspirants) and training of 2.3 lakh students (UG/ PG level), research scholars, faculty, etc. in various formal/non-formal courses in the advanced and emerging areas of Information Security and innovation activities. In addition, more than 12 crore beneficiaries comprising school children & teachers, college students & faculty, women, specially-abled, senior citizens, government employees, MSMEs, other non-IT users, CSCs, NGOs, CSOs, etc. are envisaged to be covered under the Cyber Aware Digital NaagriK (Mass Awareness) component through direct/indirect mode. The project is implemented through 50 institutions comprising select academic institutions (IITs/ NITs), autonomous organizations of MeitY (C-DAC/ NIELIT), and Technical Universities in a hub-n-spoke mode.

By December 2025, 20,236 candidates have been trained in various formal/non-formal courses, professional training programs, innovation and other activities in Information Security through 50 institutions. Under the awareness component, 2,552 awareness workshops on Information Security have been organized through direct/virtual mode for school & colleges students, teachers, faculty, Government personnel, general user 5,71,544 participants and around 10 crore estimated beneficiaries have been covered through indirect mode.

MeitY spearheaded a nationwide awareness campaign on Safer Internet Day, observed on February 11, 2025, to promote safe and responsible use of the internet. Organized under the theme 'Together for a Better Internet', the campaign aimed to educate and sensitize internet users about cyber hygiene, online safety practices, and emerging cyber threats. This initiative was conducted under the Information Security Education and Awareness (ISEA) program in collaboration with NIC, NIXI, C-DAC, NIELIT, MyGov, NeGD, and various partner institutions. The National Informatics Centre (NIC) played a crucial role in amplifying the outreach efforts through its extensive digital infrastructure and communication networks. As part of this extensive campaign, 1,521 awareness workshops were conducted across 35 States/UTs, 599 districts, 493 blocks/tehsils, and 134 gram panchayats, reaching over 3.08 lakh beneficiaries. These workshops covered key topics such as cyber threat mitigation, digital security best practices, and responsible online behavior. Additionally, a series of expert talks, quizzes, and competitions were organized to further reinforce awareness.

### 7.4.2 FutureSkills PRIME (Programme for Re-skilling/Up-skilling of IT Manpower for Employability):

Ministry of Electronics and Information Technology (MeitY) has initiated a programme titled "FutureSkills PRIME", jointly with NASSCOM aimed at re-skilling/ up-skilling of candidates in new/emerging technologies, namely Artificial Intelligence, Robotic Process Automation, Augmented/Virtual Reality, Internet of Things, Big Data Analytics, Additive Manufacturing/ 3D Printing, Cloud Computing, Social & Mobile, Cyber Security and Blockchain. FutureSkills PRIME is available as an online platform for digital skills training, which is hosted at <https://futureskillsprime.in/>. On this platform, premium contents are made available to candidates, to facilitate anytime, anywhere learning, in line with their aptitude and aspirations.

Under the programme, IT-ITeS Sector Skills Council (SSC) NASSCOM is the Key Implementing Agency. In addition, 22 C-DAC/ NIELIT Centres have been grouped as Lead & Co-Lead Resource Centres (RCs) for the 10 emerging technologies.

By December 2025, more than 26.23 lakh candidates have registered on the portal, out of which there have been 16.66 lakh+ candidates enrolled/trained in various courses. In addition, 25,530 Government officials, 2,367 trainers and 33,722 students (under 344 Bootcamps) have been trained through CDAC and NIELIT centres.

### 7.4.3 SwaYaan - Capacity building for human resource development in Unmanned Aircraft System (Drone and related Technology):

The project 'SwaYaan - Capacity building for Human Resource Development in Unmanned Aircraft System' was approved by MeitY on 11.07.2022. The administrative addendum for the Project defining the allocation of Implementing Institutes and respective Work Theme was issued on 09.09.2022 for a period of 05 years. Under the project, implementation is being carried out by 30 premium institutions, in a hub-n-spoke mode, comprising 5 Resource Centres, 15 Academic Participating Institutes (PI-Academic), and 10 C-DAC/NIELIT Participating Institutes (PI-C-DAC/NIELIT) Centres. The primary objective of the Program is to leverage collaborative activities in human resource development through capacity building in education, training, and research at UAS.

By December 2025, 29,121 beneficiaries have been trained through 843 activities conducted by 33 Institutions/Implementing Agencies through 14 categories of programs.

Under the programme, MeitY in collaboration with the Drone Federation India (DFI), launched the National Innovation Challenge for Drone Application and Research (NIDAR). The challenge was formally inaugurated by Secretary, MeitY, and Chairman, AICTE who unveiled the official concept video, launched the website and registration portal (<https://nidar.org.in>) and released the NIDAR Poster and Rulebook.



MeitY in collaboration with the Drone Federation India (DFI), launched the National Innovation Challenge for Drone Application and Research (NIDAR).

### 7.4.4 Work-Based Learning Programme to Strengthen and Empower SC/ST/WOMEN/EWS Graduate Engineers through MeitY Institutions

MeitY has approved a project entitled "Work Based Learning (WBL)" programme to Strengthen and Empower SC/ST/Women/EWS Graduates/Postgraduates through MeitY Institutions on 09.03.2022. The project is being implemented across the following seven (7) organizations of MeitY i.e. CERT-IN, C-DAC, NIELIT, STQC, CMET, ERNET, and SAMEER. The WBL project provides an opportunity for candidates to get exposed to various Design/ Developmental/ Research activities being carried out by Institutions under the aegis of MeitY. This Programme is expected to leverage the technical expertise of MeitY organizations on one hand and the updated knowledge base on fresh graduate engineers on the other hand, which is envisaged to provide a fillip to the employability quotient of SC/ST/EWS/Women candidates.

By December 2025, 3526 are enrolled and 2338 candidates have completed their tenure under the Work Based Learning (WBL) Programme. As of now more than 430 candidates are placed in various Government and Private Organizations.

### 7.4.5 Empowering Police Personnel and Governance Officials of NE states through IT and Cyber Security Training.

The Ministry of Electronics and Information Technology (MeitY) has approved the "Empowering Police Personnel and Government Officials of NE States through IT and Cyber Security Training" project on 26.02.2024. The primary objective of the proposed project is to enhance IT literacy, strengthen cyber security, and improve cybercrime investigation skills. It focuses on training of 18,660 personnel over the period of 3 years in handling digital evidence, cyber forensics, and

utilizing advanced tools. Key objectives include promoting awareness of cyber laws, enhancing data security, enabling efficient technology use in governance, building incident response capacity, fostering collaboration among stakeholders, and bridging the digital divide in remote areas. The program also emphasizes public awareness, integrates a Learning Management System (LMS), and develops a Virtual Training Environment (VTE) for hands-on cyber security training.

By December 2025, the Resource Centre's have trained 8,714 Government Officials. The Awareness training (6 hrs) has been completed, and the Basic training (20 hours) is currently ongoing. Additionally, cybersecurity labs have been established in each Northeast (NE) state capital (8 locations) and in 9 selected district locations across NE states, making a total of 17 fully set-up labs. The development of a Virtual Training Environment (VTE) has been completed, and the Learning Management System (LMS) is fully developed and live.



#### 7.4.6 Finishing School Program on 3D Printing & Additive Manufacturing Technology for Engineering Students of West Bengal and Bihar:

The Ministry of Electronics and Information Technology (MeitY) has approved the project titled “Finishing School Program on 3D Printing & Additive Manufacturing Technology for Engineering Students of West Bengal and Bihar” for a duration of 60 months, from 05.08.2024. The programme is being implemented to establish state-of-the-art Centres of Excellence (CoEs) equipped with modern 3D printing and additive manufacturing facilities in selected engineering colleges across West Bengal and Bihar. The primary objective of the project is to equip engineering students and youth with industry-relevant theoretical knowledge and hands-on skills in emerging manufacturing technologies. The programme focuses on bridging the industry–academia gap through practical modules, workshops, and boot-camp programmes aligned with current and future industrial requirements.

By December 2025, 7 state-of-the-art Centres of Excellence (CoEs) have been established across West Bengal and Bihar as regional hubs for training and innovation in 3D Printing and Additive Manufacturing Technology. These centres are equipped with advanced 3D printing systems covering multiple technologies such as FDM, LDM, PolyJet, SLA, and DMLS, along with post-processing facilities including Ultrasonic Cleaners, Water Jet systems, Agitation Tanks, and Sintering Stations. Structured Light 3D Scanners have also been deployed to support reverse engineering applications. 1,360 students have successfully completed the training programme, while an additional 530 students are currently undergoing training.

#### 7.4.7 Chips to Startup (C2S) Programme

Chips to Start-up (C2S) Programme is an umbrella programme initiated by Ministry of Electronics and Information Technology (MeitY) with an outlay of Rs. 250 Crore for 5 years in the year 2022 with an aim to generate 85,000 number of industry-ready manpower at B.Tech, M.Tech, and PhD levels specialized in semiconductor chip design, VLSI (Very Large-Scale Integration) and embedded system design areas and create vibrant fabless chip design ecosystem in the country. Against the target of generation of 85,000 manpower by the year 2027, total 67,000 manpower at B.Tech, M.Tech & PhD levels have been enrolled till date and are being trained under the Programme.

The Programme takes a comprehensive approach by offering students complete hands-on experience in chip design, fabrication, and testing. This is achieved through regular training sessions, conducted in collaboration with industry partners, and by providing mentorship and access to chip design, fabrication & testing resources to students, including state-of-the-art EDA (Electronic Design Automation) tools, access to semiconductor foundries for fabricating their chips

etc. These opportunities include implementing the R&D projects under C2S Programme for development of working prototypes of ASICs (Application-Specific Integrated Circuits), Systems/ SoCs (System-on-Chips), and IP (Intellectual Property) Core designs.

113 organizations (including 100 academic institutions/ R&D organizations and 13 startups/ MSMEs) spread across the country are supported for implementation of R&D projects resulting into generation of ASICs (Application-Specific Integrated Circuits), Systems/ SoCs (System-on-Chips), and IP (Intellectual Property) Core designs thereby generating trained manpower in these areas. The details of these organizations are at <https://c2s.gov.in/proposallist.jsp>.

The ChipIN Centre has been setup at C-DAC Bangalore as one-stop centre for providing the following support to academic institutions/ R&D organizations and start-ups/ MSMEs across the country (Details at <https://c2s.gov.in/SupportCentre.jsp>):

- i. State-of-the-art EDA tools: access provided to 300 academic institutions under C2S Programme (State-wise details at [https://c2s.gov.in/EDA\\_Tool\\_Support.jsp](https://c2s.gov.in/EDA_Tool_Support.jsp) )
- ii. Multi-project Wafer (MPW) fabrication services at 180nm, SCL Mohali. 122 semiconductor chips indigenously designed by students and sent for fabrication at 180nm, SCL Mohali. Out of 122 designs, 56 designs have already been fabricated. Details at [https://c2s.gov.in/MPW\\_Services.jsp](https://c2s.gov.in/MPW_Services.jsp)
- iii. Design and prototyping facility offering access of Field-programmable Gate Arrays (FPGA) to 100 academic institutions (Details at <https://c2s.gov.in/FPGA.jsp>) enables institutions to undertake a wide range of projects from basic digital design to advanced applications involving AI/ML, video processing, hardware prototyping, etc
- iv. Regular Trainings, Handholding and Mentorship: Total 250+ training sessions conducted by the ChipIN Centre in areas of VLSI design, Embedded System design & design fabrication in collaboration with semiconductor industry partners (Details at [https://c2s.gov.in/Completed\\_Training.jsp](https://c2s.gov.in/Completed_Training.jsp)).

**VLSI SMART Lab Facility:** VLSI SMART Lab Facility has been setup at NIELIT Calicut (with two labs having 100 hardware system) to train about 1 Lakh candidates in 5 Years (20,000 candidates /year) in Hardware design including VLSI Design, Embedded hardware design, Board design, etc. through NSQF aligned Courses and by providing remote access of FPGA boards ported with SHAKTI/ VEGA Processors. Total of 71,000 engineers have been trained nationwide, via training programs conducted using the SMART Lab

#### 7.4.8 Indian Nanoelectronics Users Program -Idea to Innovation (INUP-i2i)

The Indian Nanoelectronics Users' Programme – Idea to Innovation (INUP-i2i), initiated in 2008 at the Centres of Excellence in Nanoelectronics (CENs) of IIT Bombay, IISc Bangalore, IIT Delhi, IIT Kharagpur, IIT Madras, and IIT Guwahati, aims to advance the concept of open national nano centers. The programme focuses on providing multi-level training, supporting R&D projects, and mentoring start-ups in the field of nanoelectronics.

Under INUP-i2i, 59 familiarization workshops, 46 hands-on training sessions, 41 industrial trainings, and 11 hackathons have been conducted, benefitting over 8,589 researchers and students and facilitating the completion of 584 R&D projects nationwide.

A major milestone under the initiative has been the development and NCVET approval of two standalone National Occupational Standards (NOSs) on Nanotechnology—

- Foundation Program on Nanoscience & Technology (NSQF Level 6, 60 hours) – NQR ID: 3809
- Advanced Program on Nanoscience & Technology (NSQF Level 6.5, 90 hours) – NQR ID: 3808

These programs are aligned with the National Skills Qualifications Framework (NSQF) and are integrated with the Academic Bank of Credits (ABC) system, enabling seamless transfer of credits—2 credits for Level 1 (Foundation) and 3 credits for Level 2 (Advanced). This integration bridges academic learning with skill-based outcomes, promoting a credit-linked, modular approach to higher education and skilling.

So far, 31 participants have been awarded NSQF Level-2 (Advanced) certificates upon successful completion of the training course, marking a significant step toward creating a skilled workforce in the nanoelectronics domain.



Location of participating institutes in INUP-i2i Programme.

## 7.5 Establishment of Intelligent Educational Infrastructure (Smart) in Eklavya Model Residential Schools (EMRSs):

The project is approved by the MeitY to be implemented by ERNET India. The objective of the project is to Setting up of intelligent educational infrastructure (Smart) in Eklavya Model Residential Schools (EMRSs) by creating an eco system using the latest tools and technologies, which helps to improve the learning outcome and provides Internet connectivity in Eklavya Model Residential Schools (EMRSs).

By December 2025, a total 328 EMR schools are covered in three phases (Phase-1: 48, Phase-2: 126 and Phase-3: 154). All works including setting up of Internet link in 48 EMR schools of Phase-1 have been completed. The smart classes have been setup in all 126 EMR schools and Internet link has been setup in 82 schools out of 126 schools of Phase-2. The work of setting up internet link in the remaining schools is in progress. These smart classes are being used for promoting e-education in the growth and development of the tribal students and to bridge the digital divide by using latest technology.

## 7.6 Grass-Root Level

### 7.6.1 Create skill development facilities in deprived areas through the strengthening of the National Institute of Electronics and Information Technology (NIELIT)

NIELIT is now Deemed to be University under Distinct category as per UGC (Institution Deemed to be Universities) Regulations, 2023. It is the only University under Ministry of Electronics and Information Technology. It has its main campus at Ropar, Punjab 40 kilometres from Chandigarh, on the Chandigarh–Jalandhar National Highway. NIELIT Deemed to be University has 11 constituent centres at Agartala, Aizawl, Ajmer, Aurangabad, Calicut, Imphal, Itanagar,

Kohima, Gorakhpur, Patna and Srinagar. The Deemed to be University is offering IT and Electronics programs which are Research and industry-relevant. The University is offering Doctorate, Post Graduate, Undergraduate and Diploma courses across its 11 constituent centres.

It is a pioneering Deemed to be University dedicated to shaping the future through education, innovation, and research. Established with a vision to redefine the learning experience, we are committed to nurturing intellectual curiosity and fostering creativity. With distinguished and industry professionals as faculty and state-of-the-art facilities and emphasis on interdisciplinary learning, we are focused on preparing our students to excel in an ever-evolving technological world. The focus of the University is:

- To carry out the academic processes in accordance with global standards through active teacher-student-industry participation.
- To promote research, innovation and entrepreneurship in collaboration with industry, research laboratories and academic institutions of global repute.
- To inculcate high moral, ethical and professional values amongst our students, faculty & staff.
- To contribute in building skillful society.

Five new NIELIT Centres opened at Muzaffarpur (Bihar), Balasore (Odisha), Tirupati (Andhra Pradesh), Lunglei (Mizoram), and Daman in the Union Territory of Dadra and Nagar Haveli and Daman and Diu (DNHDD).

### NIELIT Digital University:

The NIELIT Digital University is a virtual learning platform created to provide high-quality digital education in cutting-edge technologies. NIELIT Digital University Platform. The NIELIT Digital University Platform (ndu.digital) has been developed with the vision of creating a world-class, inclusive, affordable, and employment-oriented digital learning ecosystem. Its purpose is to democratize access to high-quality digital education, support the goals of Digital India, NEP 2020, and Skill India, and build a globally competitive workforce in emerging technologies such as Artificial Intelligence, Semiconductors, Cyber Security, and Cloud Computing. The platform offers NCVET-approved, NSQF-aligned programmes with credit transfer through the Academic Bank of Credit (ABC), industry-integrated courses, virtual labs, multilingual learning, and verifiable digital certificates. With AI-driven tools like career pathways, mentors, interview simulators, and interactive modules, the platform aims to empower learners across India, targeting 40 lakh learners by 2030.

The platform is designed to,

- Offer flexible online programs in areas such as Artificial Intelligence, Cybersecurity, Data Science, and Semiconductors
- Include virtual labs for hands-on training in a remote learning format
- Strengthen the link between academic training and industry demands through collaborations and certifications

This move aims to address the digital divide and create a nationwide talent pool trained in emerging technologies.



**Hon'ble Minister, MeitY launches the NIELIT Digital University, a platform designed to democratize access to high-quality digital education on 2<sup>nd</sup> October 2025**

## 7.6.2 Capacity Building in IECT including training in Digital Skill sets and Current Industry Demanding Technologies for various sections of society in the NE States:

The project has been conceptualized by NIELIT Centres in the North Eastern Region to address existing gaps in technological skilling and digital awareness. The initiative seeks to strengthen digital awareness, inclusion, and skill development across the region through eight NIELIT Centres, leveraging mobile ICT laboratories to extend outreach to remote and underserved areas. The project aims to promote awareness and provide training in digital services for citizens across all sections of society, including farmers, women, elderly persons, students, and school dropouts. It also focuses on delivering job-oriented and industry-aligned courses in emerging and in-demand technologies to enhance employability. Additionally, the programme emphasizes up-skilling and re-skilling of teachers and NIELIT staff, while fostering a supportive ecosystem for local start-ups and entrepreneurship within NIELIT campuses, thereby contributing to sustainable regional development.

By December 2025, a total 1,71,710 candidates have been trained.

## 7.7 IT for Masses Programme

IT for Masses Programme is aimed at initiating/ promoting activities in IECT for focus groups (Women, Scheduled Caste, Scheduled Tribe, Senior Citizens, Differently Abled & economically weaker Section) and underprivileged areas (North Eastern Region, Backward Districts and Blocks & Districts having more than 40% SC/ST population) for their development and empowerment. The activities undertaken are through Infrastructure Creation, Deployment of IT tools, Training, Capacity Building & Entrepreneurship Creation activities in IECT.

The following activities have been taken under the programme:

### a. IT & Electronics Training

- Skill development in 81 Aspirational districts and 100 backward districts through NSQF aligned ICT courses for upliftment of SC/ST & Women (EWS) youths.

### b. Infrastructure Creation

- Modernisation of handloom sector at Leh through IT-enabled incubation centres.
- Establishment of design and assembly labs for Solar-led products at Leh and Kargil districts of Ladakh

### c. Capacity Building

- Establishment of CyberGyan lab for building capacity of engineering graduates/post graduates in cyber security.
- Capacity building of engineering graduates/post graduates in “IoT technologies” on PAN India level.
- Capacity building of 10th /12th pass and graduates in Multimedia and Animation, 3D printing, Mechatronics etc.
- Capacity building in IT services and digital marketing.

By December 2025, more than 10008 (SC: 5102, ST: 2795, Women: 1124, EWS: 963 and OBC: 24) nos. of candidates have benefited.

### d. Fee reimbursement

As per the directions and guidelines received from NITI Aayog (erstwhile Planning Commission) by MeitY (erstwhile DeitY) vide their communication No.D.O.No.M13054/2/2005-BC dated 05.09.2007, no fee should be charged from the SC and ST candidates for educational and skill development programmes by the Government and autonomous institutions and the expenditure for the Scheme should be accounted for from the SCSP and TSP fund of the respective Ministries/Departments.

Since 2007-08, the National Institute of Electronics and Information Technology (NIELIT) is implementing the “Fee Reimbursement to SC/ST” programme. The aforesaid programme is a DBT on-boarded scheme in which free training is being provided to the SC/ST candidates in various formal, non- formal, and IT literacy courses at NIELIT’s own centres under budgetary support of MeitY.

During the FY 2024-25, a total of 3667 Scheduled Caste and 19495 Scheduled Tribe Candidates benefitted under the Fee reimbursement programme.

During the FY 2025-26 (1<sup>st</sup> lot) covering the period, April-September 2025, a total of 3001 Scheduled Caste and 11926 Scheduled Tribe Candidates benefitted under the Fee reimbursement programme.

## 7.8 E-Learning Platform

### 7.8.1 Development of EdTech Platform in the Semiconductor Space to Democratize Chip Design and Development Ecosystem for the Masses:

MeitY has approved the project titled “Development of EdTech Platform in the Semiconductor Space to Democratize Chip Design and Development Ecosystem for the Masses” to be implemented by NIELIT Headquarters over a period of three years. The project aims to develop high-quality audio-visual content for both basic and advanced skills in chip design including physical design, RTL design, design for test, Analog design, and verification entirely using open-source technologies, with rich lectures, demonstrations, and labs to simplify complex concepts. It also seeks to build an indigenous open-source platform offering advanced EDA design tools supporting all major chip design verticals such as PDK development, RTL design/integration, synthesis, placement and routing, static timing analysis, logical equivalence checking, power estimation, DFT implementation, ATPG, Analog IP design, digital verification, and Analog/mixed-signal design and verification. The platform will enable low-cost IC design, support development of open-source IPs and SoCs at scale, lower entry barriers for students and entrepreneurs, and offer lifetime access for users to practice and strengthen their chip design skills. Additionally, the project will establish vertical-wise vibrant learning communities moderated by expert mentors to foster collaborative learning and innovation.

By December 2025, two course curricula have been designed and formally approved by the Syllabus Committee of NIELIT: (a) Chip Craft: RTL, IP Integration, and SoC Signoff, and (b) Bootcamp on VLSI Design using Open-Source Tools. Video content is currently under development for both courses, alongside the preparation of corresponding lab exercises to support hands-on learning. Cloud services for the edtech portal have been procured, and a virtual lab leveraging open-source tools is being developed. The virtual lab is already functional on the cloud platform, with ongoing upgrades to the toolset. Additionally, a Learning Management System (LMS) is being developed to facilitate access to both the course content and the virtual lab.

### 7.8.2 OLabs NextG (OLabs Next Generation):

MeitY has approved the project titled “OLabs NextG: Next Generation Online Labs (OLabs) for schools” which is being implemented by CDAC, Mumbai jointly with Amrita Vishwa Vidyapeetham, Kerala. OLabs portal (<http://www.olabs.edu.in>) is a resource point for access to online labs that cover all experiments as per the CBSE curriculum for Physics, Chemistry, Biology, Science and also activities under Maths, Social Science, Computer Science, EDP, and Languages (English, Hindi, and Sanskrit). 173 labs Physics, Chemistry, Biology, and Maths are available in regional languages Hindi, Marathi, Malayalam, etc. OLabs NextG (OLabs Next Generation) which is aligned with the New Education Policy 2020 has been approved and jointly funded by MeitY and the Ministry of Education (MoE).

By December 2025, a total of 423 virtual labs covering Physics, Chemistry, Biology, Science, Mathematics, Social Science, Computer Science, and Languages (English, Hindi, and Sanskrit) for classes 6 to 12 have been developed and made available on the OLabs website ([olabs.edu.in](http://olabs.edu.in)). Out of these, 212 OLabs are also accessible through the

DIKSHA Virtual Labs portal. The OLabs mobile application (version 1.0.15) has been hosted on both the GOV.in App Store and Google Play Store, while the OLabs Windows installer (version 2.2) has been released with three separate class-wise installers for classes 6–8, 9–10, and 11–12. Additionally, the offline e-version of OLabs has been deployed in 142 schools across 33 districts of Rajasthan, covering 342 devices. To further foster innovation, the OLabs.

### 7.8.3 MedSIM 2.0 (Online Skills Lab and Virtual Patient Cases):

MeitY has approved a project titled 'MedSIM 2.0 - Online Skills Lab' and Virtual Patient Cases for the development of a Medical Simulation platform for medical students being implemented jointly by CDAC, Thiruvananthapuram, Amrita University and AIIMS Bhubaneswar. MedSIM (Medical Simulation Platform for Medical Students) is a simulation-based medical education platform that allows medical students to enhance their clinical reasoning and judgment skills. Key objectives of the MedSIM (2.0) <http://medsim.in> is to design and develop a Preclinical and Paraclinical Online Skills Lab, develop New Virtual Patient Case Simulations to cover the entire MBBS curriculum, Aligned with MBBS Regulations 2020, National Medical Commission, enhance existing MedSIM (1.0) platform with Authoring tool, Learning Analytics, Assessment & Feedback and training of 5,000 medical students and 1,000 medical faculty from 500 medical colleges.

By December 2025, a total of 100 clinical cases and 38 pre/para labs have been studied. Currently, 72 simulation-based clinical cases and 25 skills labs have been added to the website from 24 departments.



# 8

## Statutory Organisations

### CHAPTER

#### 8.1 Controller of Certifying Authorities (CCA)

##### 8.1.1 Introduction

The Controller of Certifying Authorities (CCA) has been appointed by the Central Government under section 17 of the Information Technology Act (IT Act 2000) for purposes as defined in the Act. The Office of the CCA came into existence on November 1, 2000. Since then, the Office of CCA is executing its statutory functions under the administrative control of the Ministry of Electronics and Information Technology. It aims at promoting the growth of E-Commerce and E-Governance through the wide use of digital signatures.

The Information Technology Act, 2000 facilitates the acceptance of Electronic Records and Electronic Signatures through a legal framework for establishing trust in digital transactions.

The Controller of Certifying Authorities (CCA) established the Root Certifying Authority of India (RCAI) under section 18(b) of the IT Act to digitally sign/certify the public keys of Certifying Authorities (CA) in the country. The RCAI is operated as per the standards laid down under the Act. The CCA certifies the public keys of CAs using its own private key, which enables users in cyberspace to verify that a given certificate is issued by a licensed CA. The IT Act provides for the Controller of Certifying Authorities (CCA) to license and regulate the working of Certifying Authorities. The Certifying Authorities (CAs) issue digital signature certificates for the electronic authentication of users in the cyber world.

##### 8.1.2 Root Certifying Authority of India

###### 8.1.2.1 Root CA

The model adopted by India is a hierarchical PKI with the trust chain starting from the Root Certifying Authority of India (RCAI). RCAI is operated by the CCA, Government of India. Below RCAI, there are Certifying Authorities (CAs) licensed by CCA to issue Digital Signature Certificates of Class 2 and Class 3, which cater to various levels of authentication, assurance, and security requirements for individuals, organizations, and servers.

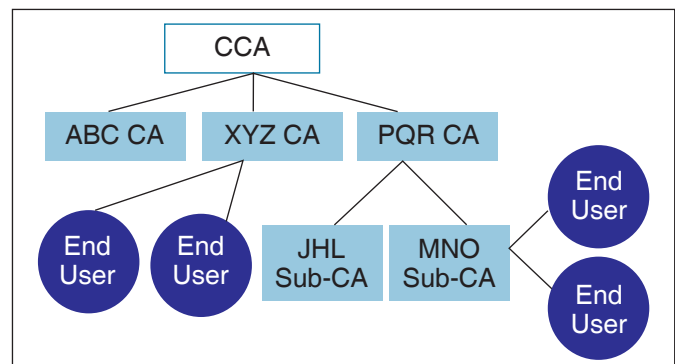

Figure 1. Hierarchical structure of Root Certifying Authority of India

The IT Act provides for the Controller of Certifying Authorities (CCA) to license and regulate the working of Certifying Authorities (CA). The following are some of the functions of CCA

- Function as Root Certifying Authority of India
- Certifying the public keys of the CAs.
- Laying down the standards & Guidelines to be followed by the CAs,

- Licensing Certifying Authorities (CAs) and supervising their activities.
- Addressing the issues related to the licensing process
- Approving the Certification Practice Statement (CPS)
- Auditing technical and physical infrastructure through empanelled auditors.
- Resolving conflict of interest between CAs and subscribers

The Root Certificates of CCA form the trust anchor for all licensed CA certificates and DSCs. In 2022, two new 4096-bit self-signed Root Certificates, CCA India 2022 and CCA India 2022 SPL, were created to certify CAs issuing digital signatures and other certificates. Twenty-four (24) CAs have been certified under the new root hierarchy, with successful enrolment of these root certificates in Adobe and Microsoft products.

### 8.1.2.2 Certifying Authorities

CAs can be private sector companies, Government departments, public sector companies, or non-governmental organizations (NGOs). These are also called Licensed CAs. At present, there are twenty-four CAs licensed by Root CA, and all of them are operating under the same policy, standards, and verification methods, subject to being audited by the criteria set by Root CA. The policy IDs of certificates are also the same for all CAs. CAs are required to provide DSCs, eSign, CRL, OCSP, and Timestamping Services. CAs are not allowed to issue certificates other than those mentioned in the CPS, which is approved by CCA.

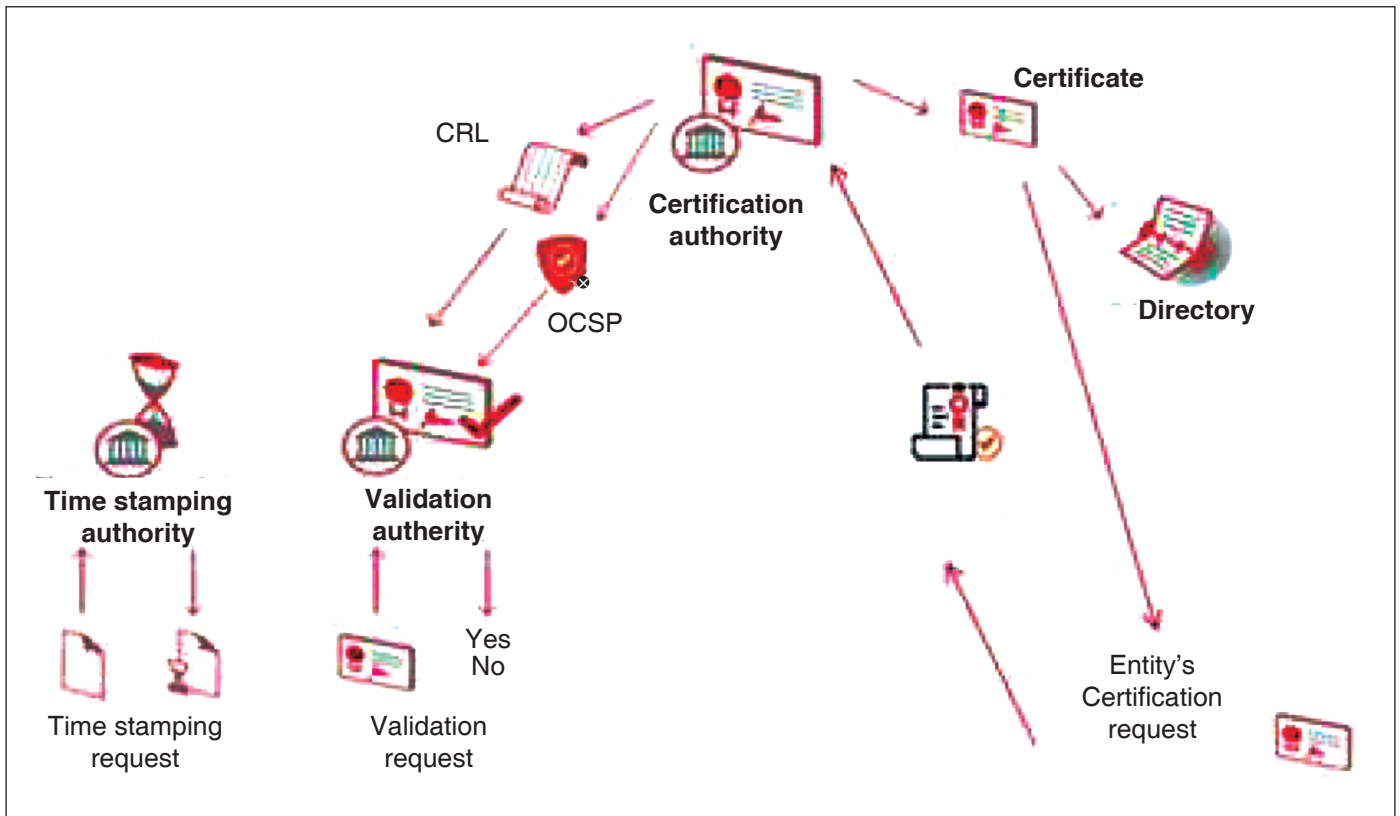

**Figure 2. Overview of Technical Operations as Certifying Authorities**

The certificates issued by Licensed CAs are legally valid in India. A Certifying Authority can create sub-CAs to meet the business branding requirement. These sub-CAs, which will be part of the same legal entity as the CA, will issue certificates to the end entities or subscribers. The CAs are allowed to create ONE level of sub-CA only. CA are required

to operate under the provisions of Act, Rules, Regulations and orders issued by CCA. The orders issued by CCA are published in the form of Guidelines.

The license is issued for a period of 5 years. CAs are required to renew the license after the expiry of the license. The license is subject to suspension, revocation and renewal. The terms and conditions for the renewal are same as fresh license. The license is issued based on eligibility criteria like net worth, paid-up capital and compliance to technical and physical infrastructure in accordance with the provision under Act.

### 8.1.2.3 Electronic Signature Certificates

To obtain an Electronic Signature Certificate from a Certifying Authority (CA), applicants must complete verification as per the Identity Verification Guidelines (IVG) issued by the Controller of Certifying Authorities (CCA).

The entire process, including application submission and verification, is fully electronic. KYC verification can be completed through Aadhaar (online/offline), banking eKYC, organizational eKYC, PAN-based eKYC, or direct verification. Certificates are issued in secure Hardware Crypto Tokens, valid for 1–3 years.

CA creates an eKYC account and issues an electronic Signature certificate to the applicant. As the verification process is online, the certificate can be obtained within 2-3 hours. For all categories of applicants, email ID, mobile number, photo, scanned copy of proof of identity, and scanned copy of proof of address are required to be submitted to CA.

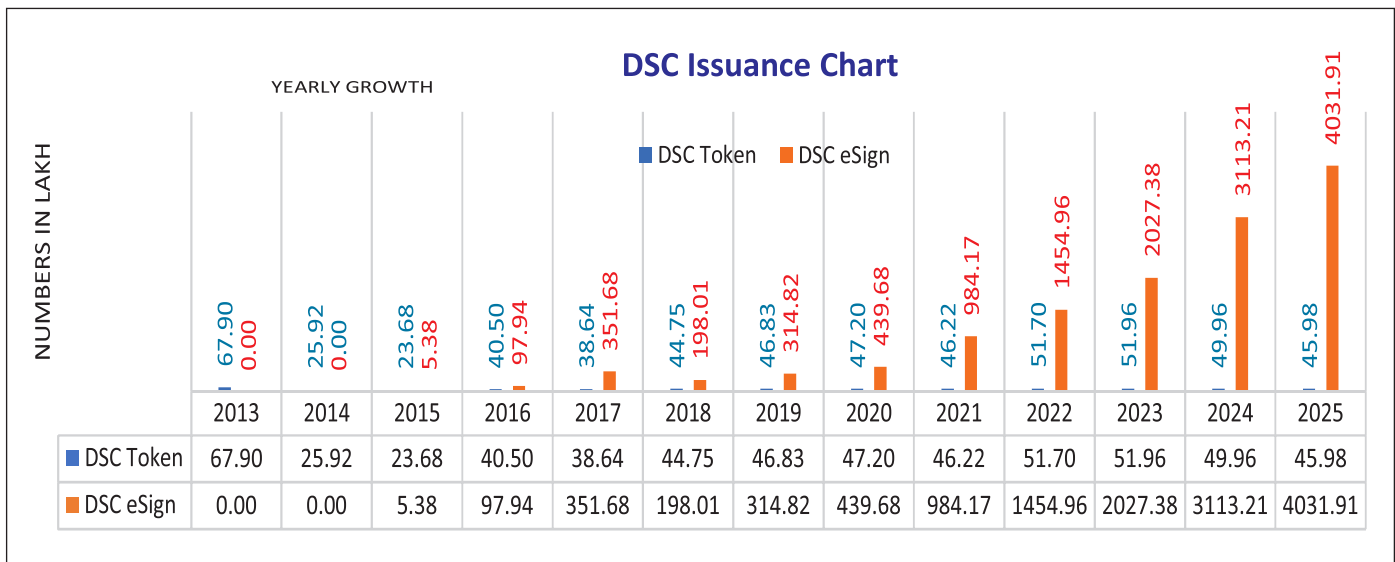

Figure 3. Yearly Growth of Electronic Signature

The total number of Digital Signature Certificates (DSC) issued in the country grew to more than **136** crore (out of which **130.19** crore DSCs are for eSign) by 31<sup>st</sup> December 2025 & continues to grow rapidly and is expected to increase significantly with the launch of various e-Governance/e-Commerce programmes.

### 8.1.2.4 Time stamping

National Physical Laboratory, India (NPLI) is responsible for maintaining and developing the Indian Standard Time (IST) using commercial cesium atomic clocks. The time scale maintained by NPLI is designated as UTC. Certifying Authorities (CAs) are mandated to derive time from the national time source for issuing electronic signature certificates and eSign services. The timestamp token must be synchronized with the Standard Time Source within an accuracy of ±1 second. CAs provide timestamping services in compliance with RFC 3161, wherein the timestamp token includes a

representation (hash value) of the data being time-stamped. The Controller of Certifying Authorities (CCA) has issued specific guidelines governing these procedures.

### 8.1.3 Services offered by Certifying Authorities

The licensed Certifying Authorities offer services to the public depending on their Organizational policy. A brief overview of the different services offered by the certifying authorities is in the table below:

**Table 1: Overview of Services available with Licensed CAs**

Sl.	CA / Entity	DSCs / eSign	Time-Stamping
1	Safescrypt	DSC	✓
2	IDRBT	DSC [Banks]	✓[Banks]
3	(n)Code Solutions	DSC	✓
4	e-Mudhra	DSC/eSign	✓
5	CDAC	eSign	eSign
6	Capricorn	DSC/eSign	✓
7	Protean (NSDL e-Gov)	eSign	eSign
8	Vsign (Verasys)	DSC/eSign	✓
9	Indian Air Force	DSC [IAF]	✓[IAF]
10	CSC	DSC/eSign	✓
11	RISL (RajComp)	DSC/eSign	✓
12	Indian Army	DSC [ARMY]	✓[ARMY]
13	IDSign	DSC	✓
14	CDSL Ventures	eSign	eSign
15	Panta Sign	DSC	✓
16	Xtra Trust	DSC	✓
17	Indian Navy	DSC [NAVY]	✓[NAVY]
18	ProDigiSign	DSC	✓
19	SignX	DSC	✓
20	JPSL	DSC	✓
21	Care4Sign	DSC	✓
22	IGCAR	DSC [IGCAR]	✓[IGCAR]
23	Speed Sign	DSC	✓
24	Assam Rifles	DSC [AR]	✓[AR]

[\*] Issuance is restricted to the respective organization or domain.

### 8.1.4 Digital Locker Authority (DLA):

Under the Digital India Programme, the Government of India aims to provide citizens with shareable private cloud storage and digitize their documents and records for real-time accessibility. The framework for the Digital Locker

Ecosystem has been established by the Controller of Certifying Authorities (CCA), who also functions as the Controller of Digital Locker Authority (CDLA).

A new Digital Locker Service Provider (DLSP) data exchange model has been introduced to remove Aadhaar dependency, ensuring compliance with the updated Aadhaar Act while allowing secure access to issuer data within the ecosystem.

### 8.1.5 Major Initiatives:

**8.1.5.1 National Centre for Digital Trust (NCDT):** The National Centre for Digital Trust (NCDT), established under the Controller of Certifying Authorities (CCA), MeitY, Government of India, was inaugurated on July 30, 2025, at C-DAC, Bengaluru. Envisioned as a national hub, NCDT aims to unify and strengthen India's digital trust ecosystem by integrating efforts in PKI, digital authentication, PQC, and trust technologies. It focuses on research, innovation, standards development, capacity building, and fostering international collaborations in digital trust infrastructure.

**8.1.5.2 Security Requirement for Crypto Devices:** In line with the 'Aatmanirbhar Bharat' initiative, CCA, MeitY, has revised security requirements for crypto devices, enabling Indian token vendors to make/assemble secure tokens for issuing Class 2 and Class 3 DSCs.

**8.1.5.3 Portal for licensing of Certifying Authorities and Dashboard for DSCs:** The said portal will facilitate online submission of applications for the grant of license, management of different kinds of audits, and provide a Dashboard for DSCs issued by CAs. Also, the application for renewal of the license will be submitted in the form of an electronic record as per Section 15(3) of IT(CA) Rules. The development work of said portal has been completed.

**8.1.5.4 Establishment of SSL Root with WebTrust certification:** CCA is establishing an SSL Root with WebTrust certification. A MoU has been signed with NIXI, MeitY for the same, and work for the establishment is at an advanced stage of execution. Establishment of an SSL root with WebTrust certification will facilitate acceptance of the SSL root certificate in all the browsers and various software.

**8.1.5.5 Post Quantum Cryptography (PQC) Migration Roadmap:** A PQC roadmap has been developed for transitioning to PQC, and R&D work for the same is initiated in collaboration with various prominent organizations working in this area. This will facilitate advanced root CA setup and licensed CAs working there under.

#### 8.1.5.6 Important Projects/assignments executed/under execution under by CCA:

- a) **Development of Secure Post Quantum Public Key Infrastructure:** A Secure Post-Quantum Public Key Infrastructure (PQ-PKI) is being developed, integrating quantum-safe algorithms and hybrid certificates to ensure long-term digital trust and interoperability across critical domains.
- b) **Development of PKI-based Digital Certificates for IoT Device Security with PoC showcasing use-cases Smart City, Drone, Automotive Industry:** A unique approach framework to integrate diverse digital certificates under CCA, MeitY's trust hierarchy, enabling PKI-based trust for Automotive, Drone, and Smart City domains.
- c) **Common API Platform and method to fetch the number of digital signatures signed through DSC Token:** Platform was developed to securely track DSC-based digital signatures. The Digi-Hastakshar tool for signing PDF, Word, Excel, and images was launched on 28th July 2025 via C-DAC Noida.
- d) **Blockchain-based Digital Signature Certificate Validation and storage System with a Smart Dashboard:** Secure system was developed for validation, tracking, and storage of Digital Signature Certificates, ensuring transparency and real-time monitoring, successfully executed through C-DAC Bengaluru and C-DAC Hyderabad.
- e) **Implementation of ISO 27001 for Web Trust Compliance to Root Certifying Authority of India (RCAI):** Successfully, CCA achieved ISO 27001 Certification, strengthening security and compliance standards.

- f) Participating in National Quantum Mission (NQM) as part of the task force/ and its sub-committees for establishing a Quantum Safe Ecosystem in India.
- g) Participating as a Task Force member for the development and implementation of the Intelligent Transportation System (ITS) to enhance secure and efficient vehicular communication infrastructure.
- h) Standardization of Security Audit & Testing requirements for development of the Indigenous token.

### 8.1.6 Workshops & Conferences

A series of Digital Signature and Public Key Infrastructure events were organized from 5th to 6th September 2025 in Bangalore:

- The First-ever North East Science, Technology, and Industrial Expo 2025, held from 27th to 30th October 2025 at Shillong, showcased its pivotal role in enabling secure digital transformation and strengthening trust within India's digital ecosystem.
- 6<sup>th</sup> International Conference on Public Key Infrastructure and its Applications (PKIA 2024)- A Joint Conference by IEEE CS & IAS Bangalore Chapter (5-6<sup>th</sup> September 2025).
- Tech Expo 2025 exhibition was organized under the theme of "Digital Trust Ecosystem", featuring state-of-the-art technologies, new and/or indigenously developed products and solutions in this domain. The event was co-located with the 6<sup>th</sup> IEEE International Conference on Public Key Infrastructure and its Applications – PKIA 2025. Five organizations (CDAC Bangalore, CDAC Noida, TVS Sensing, E-Mudhra, and Precision) participated. Solutions like PKI for automotive, PKI for Drone, Mobile PKI, Biometric based Crypto-token, qHastakshar, etc. were displayed.

## 8.2 Unique Identification Authority of India (UIDAI)

### 8.2.1 Introduction

**8.2.1.1** The Unique Identification Authority of India (UIDAI) was established to develop the policy, procedure and systems for issuing Aadhaar numbers to individuals and perform its authentication. Accordingly, it has been UIDAI's endeavour to develop policy, procedure and systems that would enable individuals to get Aadhaar numbers issued and to perform authentication to establish their identity.

**8.2.1.2** UIDAI was set up through a Government notification dated 28<sup>th</sup> January 2009 as an attached office of the Planning Commission, to lay down plans and policies to implement the UID Scheme and to own, operate, update and maintain the UID database. The first Aadhaar number was issued on 29<sup>th</sup> September 2010.

**8.2.1.3** Following the enactment and coming into force of the Aadhaar (Targeted Delivery of Financial and Other Subsidies, Benefits and Services) Act, 2016 ("Aadhaar Act"), UIDAI was established through a notification dated 12<sup>th</sup> July 2016 of the Ministry of Electronics and Information Technology (MeitY) as a statutory authority under the Aadhaar Act.

### 8.2.2 Relevance of Aadhaar number

**8.2.2.1** The inability to establish one's identity has been a major challenge for the poor and marginalised sections of society in accessing benefits, subsidies and services made available by the government. Given the large population of India, it was difficult to identify each and every individual. Further, with a multiplicity of agencies issuing different identity documents and government departments and agencies requiring different identity documents, every time an individual sought to avail of a subsidy, benefit or service, she or he had to undergo a fresh cycle of identity creation and/or verification, which typically entailed possession of some other documents. Such duplication of efforts and "identity

silos” not only increased the overall cost of delivery of subsidies, benefits and services but was also not in the interest of furthering ease of living.

**8.2.2.2** Therefore, a need was felt to create a digital identity and, to this end, the Aadhaar Act was enacted. The Act provides for good governance, efficient, transparent and targeted delivery of subsidies, benefits and services, the expenditure for which is incurred from the Consolidated Fund of India, to individuals residing in India through assigning of unique identity numbers to such individuals and for connected and incidental matters. The objective was to harness the benefits of a unique identity for all residents, which would offer a means to detect any duplication of identity and which may be authenticated/ verified in an easy, cost-effective manner.

### 8.2.3 Aadhaar Act

**8.2.3.1** The validity of the Aadhaar Act was upheld by the Hon’ble Supreme Court in its judgement dated 26<sup>th</sup> September 2018 in Justice (Retd.) K. S. Puttaswamy and Anr; vs Union of India & Ors; with certain observations and directions. The directions of the Apex Court were given effect to through an amending Act that amended the Aadhaar Act, the Telegraph Act, 1885 and the Prevention of Money-Laundering Act, 2002. The provisions of the amending Act came into force on 25<sup>th</sup> July 2019. Salient features of the amended provisions of law are as follows:

- (a) To provide for voluntary use of Aadhaar number, only with the informed consent of the Aadhaar number holder, by authentication or offline verification;
- (b) To enable use of Aadhaar authentication by State Governments as well;
- (c) To provide that services shall not be denied upon refusing to or being unable to undergo authentication;
- (d) To provide for safeguards and restrictions on the performing of authentication;
- (e) To lay down the procedure for offline verification;
- (f) To confer power upon the Authority to give such directions as it may consider necessary to any entity in the Aadhaar ecosystem;
- (g) To establish the Unique Identification Authority of India Fund;
- (h) To provide for civil penalties, adjudication and appeal;
- (i) To omit section 57 of Aadhaar Act, which permitted use of Aadhaar for any purpose, since the same had been struck down by the Apex Court; and
- (j) To allow the use of Aadhaar number for authentication on voluntary basis as acceptable KYC document under the Telegraph Act, 1885 and the Prevention of Money-Laundering Act, 2002.

### 8.2.4 Features of Aadhaar number

**8.2.4.1** Key features of Aadhaar number are as follows:

- (a) It is a 12-digit random number, generated after a process of de-duplication using biometrics to ensure uniqueness of identity;
- (b) It does not contain any intelligence and does not bear any relationship to the attributes or identity of an Aadhaar number holder;
- (c) It is created and managed using scalable technology architecture;
- (d) It operates using open source technologies; and
- (e) An individual is issued only one Aadhaar number.

## 8.2.5 Enrolment

**8.2.5.1** The enrolment process for the Aadhaar number begins with an individual seeking to enrol submitting her/his information to the enrolling agency with supporting documents for verification at any Aadhaar enrolment centre across the country. During the enrolment process, she/he is required to fill the prescribed enrolment form and submit her/his demographic and biometric information. An acknowledgement slip is given to the enrollee, containing details of enrolment and an EID number for tracking the status of enrolment.

**8.2.5.2** UIDAI has set up a nationwide infrastructure for Aadhaar enrolment in India through a network of Registrars and accredited enrolment agencies. The Registrars are largely Government departments, agencies and public sector banks. Enrolment agencies are selected through rigorous selection criteria. An individual is enrolled by a UIDAI certified operator through UIDAI software under a highly robust, controlled, non-repudiable and secure process. Individuals are enrolled for Aadhaar through certified operators, who are selected on the basis of a rigorous examination and test process. The operator authenticates every enrolment through her/his own fingerprints and Aadhaar number. In this manner, a complete account is maintained as to which operator enrolled whom, where and when, so that in case of any default, accountability of the enrolment operator and agency may be readily fixed. Thereafter, biometric data of enrolling persons are matched against the entire database of existing Aadhaar number holders, and only after checking that there is no match is an Aadhaar number generated. All enrolment data, including biometrics, are encrypted using a 2,048-bit encryption key at the time of the enrolment and are not accessible to any agency except UIDAI, which alone can access the data through a secure decryption key available only with UIDAI.

**8.2.5.3** Enrolment for issuance of an Aadhaar number and update of identity information linked to Aadhaar number is enabled through the following (information is as on 31.12.2025):

- (a) India Post – 7,890 permanent enrolment centres (PECs);
- (b) Banks – 5530 PECs;
- (c) State Government office locations – 27,197 PECs;
- (d) UIDAI – 60 Aadhaar Seva Kendras (ASKs)
- (e) CSC eGovernance Services India Limited – 893 CSC ASKs (at State, district and block level); and
- (f) India Post Payments Bank – 27,518 operators for mobile Aadhaar update and child enrolment services, offered using mobile Aadhaar enrolment kits.

**8.2.5.4** UIDAI has taken the following major initiatives for strengthening the Aadhaar enrolment ecosystem:

- (a) Document update: Considering that Aadhaar has emerged as the most widely accepted proof of identity and is being used to avail of numerous services by the Aadhaar number holder, for which they are required to submit their Aadhaar number linked with latest and updated identity information details, and with a view to provide them a facility to revalidate their demographic information (name, gender, date/year of birth and address), UIDAI has developed a new feature called “document update”, which can be accessed online through UIDAI’s myAadhaar portal or by visiting any Aadhaar enrolment centre and submitting copies of supporting documents evidencing Proof of Identity (PoI) and Proof of Address (PoA).
- (b) Adult enrolment: To ensure the robustness of the enrolment process, enrolment of adults for issuance of fresh Aadhaar numbers is now done with verification by State Nodal Officers appointed by the State Government concerned, on a portal made available by UIDAI. In order to ensure proper monitoring of the enrolment and usage of Aadhaar the State Unique Identification Implementation Committees under the chairpersonship of Chief Secretaries have been reconstituted and District Level Aadhaar Monitoring Committees have been constituted.

- (c) Child enrolment: Pursuant to the recommendations of a committee constituted under the chairpersonship of the Registrar General of India, Aadhaar numbers of both parents are now being collected and biometric authentication of one parent or legal guardian is being done at the time of enrolment of a newborn. Further, birth registration Aadhaar enrolment is being promoted across the country through issuance of Aadhaar enrolment kits to operators in hospitals, with a view to ensure enrolment of newborns at the hospital itself. Moreover, the enrolment of the biometrics of children upon attaining the age of five years and the update of biometrics upon attaining the age of 15 years is offered free of charge if such enrolment/update is done within two years of attaining such age.
- (d) Resident Foreign nationals enrolment: Special provisions were created for enrolment of a Foreign national, where the validity of Aadhaar so generated shall be restricted to the validity of VISA period in India. In case of OCI card holders and Nepalese/Bhutanese applicants the validity of Aadhaar shall be restricted to 10 years. The validity period and the term 'Foreigner enrolled as a resident' shall be mentioned in the Aadhaar Letter/Aadhaar PVC Card issued for such Aadhaar number holders.

### 8.2.6. Authentication

**8.2.6.1** Aadhaar authentication is the process wherein Aadhaar number, along with other attributes (demographics/biometrics/OTP) is submitted to UIDAI's Central Identities Data Repository (CIDR) for verification. The CIDR verifies whether the data submitted matches the data available in CIDR and responds with a "yes/no" or an e-KYC.

**8.2.6.2** The purpose of authentication is to enable an Aadhaar number holder to establish her/his identity to the authentication requesting entity, for the purpose of getting any subsidy, benefit or service provided by or through such entity.

**8.2.6.3** In both Yes/No and e-KYC authentication, the authentication requesting entity sends the Aadhaar number along with the demographic information, biometric information or mobile-based one-time password (OTP), or any combination thereof, submitted by the Aadhaar number holder, in encrypted form.

**8.2.6.4** In the case of Yes/No authentication, UIDAI validates the submitted information against information stored in its database and sends a "yes" or "no" response.

**8.2.6.5** In the case of e-KYC authentication, UIDAI validates the input parameters against the data stored therein and return a digitally signed e-KYC authentication response with encrypted e-KYC data.

**8.2.6.6 Authentication requesting entities:** All requesting entities are required to be registered with UIDAI before they may undertake authentication. Such a requesting entity is onboarded as an Authentication User Agency (AUA), enabling it to perform Yes/No authentication. In case it is to perform e-KYC authentication as well, it is also registered as an e-KYC User Agency (KUA). An AUA or KUA may, with the permission of UIDAI, appoint one or more entities as their sub-AUA or sub-KUA. All requesting entities are required to store Aadhaar numbers and any connected Aadhaar data in a separate, secure database/vault/system, called Aadhaar Data Vault.

**8.2.6.7 Authentication Service Agencies (ASAs):** ASAs provide secure Multiprotocol Label Switching (MPLS) connectivity between requesting entities and UIDAI's CIDR.

**8.2.6.8 mAadhaar mobile application:** UIDAI has developed the mAadhaar mobile app to enable Aadhaar number holders to download their e-Aadhaar from the Aadhaar database. It also provides a number of other facilities, such as ordering a PVC Aadhaar card, scanning of the secure QR code on an Aadhaar card / e-Aadhaar / Aadhaar letter, download of paperless offline e-KYC in XML format, etc.

**8.2.6.9 Face authentication:** An in-house developed AI/ML-based face authentication modality was introduced on 15<sup>th</sup> October 2021. This offers a touchless biometric authentication alternative to fingerprint or iris-based authentication. Face authentication is now seen as the digital backbone of government's flagship programmes and initiatives for good governance and social welfare, and for achieving accountability and transparency in the same. Face authentication is beneficial to Aadhaar number holders who often face difficulty in fingerprint authentication due to progressive degradation in quality of their fingerprints with their age or physical labour. Face authentication facilities are available anytime and from anywhere. Moreover, UIDAI's Face Authentication solution has been awarded the Prime Minister's Award for Excellence under Innovation Centre Category, for the year 2023. As of 31<sup>st</sup> December 2025, 142 entities have commenced using face authentication, with total of 319.82 crore transactions as against 130.31 crore transactions until 31<sup>st</sup> March 2025, reflecting a 145.43% increase in 9 months. The peak transaction count in a day has been 1.63 crore, done on 1<sup>st</sup> November 2025. Face authentication's use has showcased significant growth in Digital Life Certificate generation through Jeevan Pramaan Application, increasing from less than one percent in FY 2021-22 to almost 60% in FY 2025-26. Highest number of DLCs generated in a day has been 8.63 Lakh on 03.11.2025, of which 4.85 Lakh were generated using Aadhaar face authentication. Further, successful integration of face authentication in the Proof of Concept (PoC) proposed by Department of Financial Services (DFS) for onboarding of NRI customer of State Bank of India (SBI) residing in Bahrain has been successfully initiated by opening accounts since 7.1.2026.

**8.2.6.10** As on 31<sup>st</sup> December 2025, there are 20 ASAs, and 644 Requesting Entities (which includes 236 AUAs and 400 Sub-AUAs) in the Aadhaar authentication ecosystem. Cumulative authentication transactions have already crossed 16,800 crore since inception which includes more than 2,700 crore e-KYC transactions

**8.2.6.11** Provision of obtaining update for change of Aadhaar Status during authentication by requesting entities: UIDAI has introduced a provision to facilitate for the performance of authentication done by requesting entities (AUAs and KUAs) with update of status regarding whether an Aadhaar number previously submitted has been subsequently omitted or deactivated or re-activated. This facility of sharing the change of status of Aadhaar, including status of Aadhaar numbers deactivated on account of death of the Aadhaar number holder, has been enabled for all those requesting entities that enter into a supplementary agreement with UIDAI. On similar lines, requesting entities are also encouraged to share information with UIDAI of such Aadhaar number holders whose status is marked deceased in the data available with the requesting entities. This is expected to facilitate UIDAI as well as requesting entities in user data sanitization in respective databases.

**8.2.6.12 For generation of Baal Aadhaar:** As per requirement of Registrar General of India (RGI) and opinion of Ld. Attorney General of India, UIDAI Authority has amended the relevant Regulations, wherein after obtaining consent of parents, Aadhaar number of child will be shared with ORGI for seeding with birth certificate.

**8.2.6.13 Amendment in SWIK Rules:** UIDAI has amended the Aadhaar Authentication for Good Governance (Social Welfare, Innovation, Knowledge -SWIK) Rules, 2020, w.e.f., 31.01.2025, so that entities other than the Ministry or Department, desirous of utilizing Aadhaar authentication for a purpose specified in the interest of State, thereby "promoting ease of living of residents and enabling better access to services for them" may be requesting for onboarding with UIDAI. To automate the online process for submission of proposals by any entity 'SWIK Web Portal' is launched by Secretary MeitY on 27.02.2025.

**8.2.6.14 Introduction of L1 Registered fingerprint Devices:** To enhance security of data, UIDAI has mandated use of Registered fingerprint Devices (RD) for all biometric authentication requests. After successful migration of L0 Registered fingerprint Devices in the field, UIDAI has rolled out L1 Registered fingerprint Authentication Devices with embedded Pre-certified hardware (PCH). In L1 RDs, the signing and encryption of biometrics is implemented within the Trusted Execution Environment (TEE) where host Operating System (OS) does not have any mechanism to obtain the private key or inject biometrics. Some advantages of L1 Registered fingerprint Authentication Devices are: - (i) Signing

and encryption of biometric is implemented within the Trusted Execution Environment at the hardware level, (ii) PID block is into a more secure environment with no change in size.

Further, UIDAI strengthened liveness detection in fingerprint devices to prevent spoofing and reduce failure rates as the capture of artificial/fake fingerprints is failed at the device level post implementation of fake finger detection (FFD).

**Introduction of L1 IRIS registered devices:** To boost the security of iris-based authentication, UIDAI is moving from existing L0 IRIS registered devices to L1 IRIS registered devices, marking a big shift toward hardware-based protection. This setup uses Trusted Execution Environment (TEE) technology to offer strong defence against advanced cyber threats and spoofing attempts. The migration will roll out gradually, ensuring services stay up and running while significantly boosting the authentication system's accuracy and reliability.

**Introduction of Fake IRIS Detection (FID) in existing L0 Iris registered Devices:** On-device inference for Spoof Detection or Fake Iris Detection (FID) is being introduced in iris-registered devices, using lightweight neural networks and spectrum analysis to ensure only live, genuine scans are accepted during authentication. This device-level safeguard boosts the Aadhaar ecosystem by performing spoof detection locally, improving privacy and cutting latency. FID rollout is currently in progress across all L0 iris device vendors.

**8.2.6.15 Onboarding of States & District Co-operative Banks** to onboard customers digitally through Aadhaar authentication to enable facility such as Aadhaar payment bridge (APB) and Aadhaar Enabled Payment System (AePS):- UIDAI has framed a policy to institutionalize the process for the inclusion of States Co-operative Banks (StCBs) & District Co-operative Banks (DCBs) in Aadhaar ecosystem. After onboarding under Aadhaar ecosystem SCBs and DCBs may be integrated into Aadhaar Enabled Payment System (AePS). As per the new framework State Co-operative Banks (StCBs) and District Co-operative Banks (DCBs) will be treated as a single entity and only the StCBs will be onboarded as the Authentication User Agency (AUA) and KYC User Agency (KUA), while DCBs will access authentication services through the StCBs using a unique identifier, "DCB-ID", which will serve as an internal reference within the StCBs system. Accordingly, DCBs are not required to be onboarded separately as Sub-AUAs or Sub-KUAs.

**8.2.6.16 Onboarding Process:** Appointment of agencies employed for authentication is done on the basis of 3-tiered process consisting of initial in-principle approval of the agency to perform Aadhaar authentication as per provision of the Aadhaar Act, 2016 with authorisation document, incorporation details, undertaking to abide with the regulations and guidelines established by the Authority; followed by compliance to pre-onboarding audit as per UIDAI's guidelines on Information Security Governance, Asset Management, Incident Management and Data Security; and IS onboarding audit. After complying in full and scrutiny by UIDAI, the agency is onboarded as a live requesting entity.

Post appointment as a live requesting entity, the agency has to undergo 3-tiered audit process consisting of Self-Assessment Audit, Annual IS Audit and GRCP Audit (once in 3 years).

**8.2.6.17 Outreach Programmes:** UIDAI has been organizing a stakeholder flagship meeting called 'Aadhaar Samvaad' as well as seminars in different states with different aims to bring prominent stakeholders from Central/State Government, NBFCs, telecom industries, SEBI-regulated entities etc. Moreover, UIDAI has also been participating in Global Fintech Fest (GFF) and other national or international events.

## 8.2.7. Security measures

**8.2.7.1** UIDAI uses advanced encryption technologies for protecting data in transmission and storage. UIDAI's Information Security Management System is ISO 27001:2022-and Privacy Information Management System ISO 27701:2019 certified. Further, the CIDR has been declared as a protected system under section 70 of the Information Technology Act, 2000 and the National Critical Information Infrastructure Protection Centre provides key security inputs on an ongoing basis to maintain its cyber security posture.

**8.2.7.2** A leading global firm has been engaged to facilitate the creation of a framework for the Governance, Risk, Compliance and Performance of the Aadhaar ecosystem and oversight of the same for adherence to the framework, with a view to ensure a robust, comprehensive and secure environment.

### **8.2.8. Customer relationship management**

**8.2.8.1** UIDAI has set up an Aadhaar Sampark Kendra as the central point of contact for resolution of queries and grievances of Aadhaar number holders, accessible through the toll-free number 1947 and the email address help@uidai.gov.in. The contact centre has a mechanism to log queries and grievances and provide Aadhaar number holders with a unique reference number for tracking till closure of the matter. It also offers support in major regional languages.

**8.2.8.2** The customer relationship management system of UIDAI supports multiple channels, viz., phone calls, email, chatbot (Aadhaar Mitra), web portal, seven major social media channels, letters and walk-in as the means through which grievances may be registered, tracked and resolved.

# 9

## CHAPTER

# Attached Offices and Societies

### 9.1 Centre for Development of Advanced Computing (C-DAC)

C-DAC is a premier R&D organization under the Ministry of Electronics and Information Technology (MeitY). The organization focuses on applied research, design & development and deployment of innovative IT and electronics solutions for various key sectors.

The core research and development areas of C-DAC include High Performance Computing (HPC), Quantum Computing, Artificial Intelligence (AI), Strategic Technology (Including Emergency / Disaster Management), Digital India RISC-V (DIR-V), Software Technology (Including Cloud & BOSS), e-Governance, Healthcare & Educational Technologies, Cyber Security and Cyber Forensics, Automotive Technology, Power Electronics and Renewable Energy, Communication Technology and Internet of Things (IoT).

In the year 2025-26, C-DAC achieved notable progress in the areas of electronics and information technology through extensive research and development. The organization successfully created and implemented a range of solutions, while also establishing collaborations with renowned organizations at both national and international levels. Additionally, C-DAC played a major role in providing training opportunities and organizing various events, conferences, workshops, etc.

Key technological achievements of C-DAC during the year in each of its focused areas are outlined below.

#### 9.1.1 National Supercomputing Mission (NSM)

Details are covered in Chapter 5.

#### 9.1.2 National Level Initiatives

##### 9.1.2.1 National Mission on Power Electronics Technology (NaMPET-III)

As a comprehensive mission program, the National Mission on Power Electronics Technology Phase-III (NaMPET-III) is in the finishing stage. So far, 39 sub-projects, 9 startup engagements, 5 international visits, 26 short term courses at academic Institutes, association in dozen workshops and conferences, 30 patents, 40 copyrights, 150 publications, in the areas of Power Electronics and its applications in different sectors like Wide Band Gap (WBG), semiconductor-based PE systems, e-Mobility, Medical, Grid, Renewable Energy etc., have been completed.

Under the programme more than 20 academic institutions and industries are participating in the technology development and commercialization through Transfer of Technologies (ToT).

Following activities are undertaken by C-DAC during the period.

- Vehicle Control Unit (VCU) customised for Amrit Bharat - 22+2 coach Push pull configuration and Distributed Power Wireless Control System (DPWCS) for longer freight locomotives with 20+ coaches at ICF, Chennai

- Developed the first indigenous Train Communication Network (TCN) based Multifunction Vehicle Bus (MVB) controller for locomotives, establishing an open-architecture technology for the Vehicle Control Unit (VCU) in Indian three-phase locomotives WAG9, WAP7 and WAP5.
- Implemented Microgrid Innovation for Energy Efficiency- Kerala Development and Innovation Strategic Council (KDISC) 5 storied building, the first commercial building operating on Solar PV powered 48V DC distribution.
- Developed First indigenous Power system real time simulator and deployed at IISc.
- Developed first indigenous Technology for Planar inductor and Transformer.
- Model EV Charging Station setup at C-DAC Trivandrum campus- equipped with comprehensive solution for EV public Charging technologies developed under NaMPET, including 7kW & 22kW AC fast charger, 15kW & 50kW DC fast Chargers with SiC, Metering and user interfaces.
- Developed Integrated drive for BLDC motor for EV applications - Compact low power drive for BLDC motor integration EVIDs.
- Developed First Indigenous Electrical system emulator - Indigenous design of battery emulation @ 15kW.

These technologies are available for technology transfer at different TRL levels.

Major impact of NaMPET created technology base in the country: In a major initiative for technology development in Locomotive propulsion, Indian Railways has signed MoU with C-DAC in March 2025 for 5 Megawatt 3 Phase propulsion system with active participation of 3 Industries. This is the largest ever Power Electronics system development initiated by C-DAC in capacity wise.

### 9.1.2.2 Chips to Startup (C2S)

Details may be seen at Chapter 7.

### 9.1.2.3 Design Linked Incentive (DLI)

The Design Linked Incentive (DLI) Scheme aims to provide financial incentives as well as design infrastructure support across various stages of development and deployment of semiconductor design for Integrated Circuits (ICs), Chipsets, System on Chips (SoCs), Systems & IP Cores and semiconductor linked design with an aim to achieving significant indigenization in semiconductor and electronic products and IPs deployed in the country, thereby facilitating import substitution and value addition in electronics sector in the next 5 years.

As on September 18, 2025, total of 115 applications were received for financial support and 23 are approved for financial support. A total of 81 applications were received for EDA tool support and 74 are approved for EDA tool support.

Details may be seen at Chapter 5.

### 9.1.2.4 IndiaAI Datalab at C-DAC Mohali – Soft Launch

As a part of India-AI Mission, Hon'ble Minister of Electronics & IT, Shri. Ashwini Vaishnaw, launched 30 IndiaAI Datalabs nationwide, including the one at C-DAC Mohali which is established in collaboration with Intel Corporation India during the curtain raiser event of the AI Impact Summit 2026.

At C-DAC Mohali, the focus is on driving pioneering AI research and delivering scalable, real-world solutions across domains such as Cybersecurity, Applied Ethics, Healthcare, and Industry 4.0. In



just the last 3 months, the IndiaAI Datalab at C-DAC has already trained 75+ participants, including students, working professionals, and government officials—accelerating India’s AI-driven transformation journey. As part of upcoming initiatives, these datalabs will deliver foundation-level AI courses and training for data annotators/curators, nurturing the next generation of AI talent.

### 9.1.3 Quantum Computing

#### 9.1.3.1 Qniverse

Qniverse is a cutting-edge, unified development platform designed to support diverse quantum computing (QC) architectures and hardware platforms, making quantum computing accessible to individuals and organizations alike. It bridges the gap between the theoretical principles of quantum mechanics and the transformative practical applications of quantum technology. It is enabling users to discover the vast capabilities of quantum computing beyond the limitations of classical systems, contribute to ground breaking research and scientific discoveries and pioneer advancements in the evolving quantum era.

#### 9.1.3.2 Establishment of Superconducting-based Quantum Computing Reference Facility

The main objective of the project is the establishment of a Superconducting based Quantum Computer Reference Facility (50-100 qubits) at C-DAC which will foster collaborations, advance quantum computing technology, and enable breakthroughs in a wide range of use cases across scientific and industrial applications. This is the first-of-its-kind reference facility in the country where a 50-100 qubit superconducting-based quantum computing ecosystem will be established including the installation of a dilution refrigerator, control electronics, wiring, Quantum Processing Units (QPUs) and software stack. Additionally, it involves the creation of dedicated infrastructure, training, capacity building and implementation of collaboration agreements with industry partners. The facility can be used for developing a vibrant quantum ecosystem within the country, leapfrogging towards the advancement of quantum technology research and development.

#### 9.1.3.3 Development of Quantum Machine Learning Use Cases and Applications

Five C-DAC centres, three IITs, and IIIT Hyderabad are part of this project. The initiative focuses on harnessing Quantum Machine Learning (QML) to address real-world challenges across healthcare, surveillance, geology, cybersecurity, emergency management, remote sensing, and chemistry, while also strengthening national capacity in Quantum Computing.

#### 9.1.3.4 FinTeQ-Quantum-Safe Financial Transaction Framework

The project tries to address the issues due to quantum threats on financial transactions. It proposes to build a Quantum-Safe Financial Transaction Framework that will secure financial transactions even in the presence of a quantum-enabled adversary. The project has a two-fold approach to solving this problem:

- **B2B:** Financial transactions between financial institutions: These transactions will leverage Fiber based Quantum Key Distribution (QKD) to exchange the symmetric keys securely. These keys will then be used to secure any transaction using symmetric-key cryptography (e.g., AES-256). It can be noted that in the Quantum world, AES-256 provides 128-bit security due to Grover’s algorithm.
- **B2C, C2C:** Financial transactions between consumers or consumer and financial institutions: These transactions will be secured through indigenous secure USB dongles which will leverage Secure Application Framework based on both web and mobile platforms. They will act as an extra layer of security between the consumer and the bank/financial institution. Secure Dongle brings two-factor authentication to applications where security is critical.

### 9.1.3.5 HPC based Quantum Accelerators for enabling Quantum Computing on Supercomputers

Quantum simulators were optimized across multiple accelerator testbeds, including GPU, Vector, and FPGA platforms, to enhance their efficiency and scalability. On FPGA testbeds, hybrid quantum-classical algorithms were implemented using Qiskit, and a dedicated QSim FPGA Library was created for efficient execution of quantum algorithms. Benchmarking of quantum-enhanced algorithms were carried out for HPC offloading on CPU, GPU, and FPGA platforms. Furthermore, QSim's density matrix simulator and performance benchmarks were ported to diverse architectures, including CPUs, GPUs, and Vector processors, ensuring wide adaptability.

A major advancement was the development of QARN (Quantum Accelerated and Reconfigurable Noisy simulator), a GPU-accelerated simulator capable of simulating up to 28 qubits with notable performance improvements.

### 9.1.3.6 Metro Area Quantum Access Network (MAQAN): Quantum Communication Controller Card (QCC)

MAQAN is India's first Quantum Key Distribution (QKD) network and R&D testbed, marking a significant step towards quantum-safe communication. The network is currently operational in a 5-node topology. The project was a collaborative effort of IITM, SETS India, ERNET and C-DAC. The project led to the indigenous development of a QKD chassis with control electronics for Coherent One Way (CoW) and Differential Phase Shift (DPS) protocols, alongside a hardware and software-based key distillation engine.

### 9.1.3.7 Development of Secure Post Quantum Public Key Infrastructure

C-DAC Bangalore, C-DAC Noida along with IIT Madras, SETS Chennai and IIITD Kurnool are executing this project and its objective is to develop Post Quantum Crypto Token by implementing CRYSTALS-Dilithium (for Digital Signature Scheme) and CRYSTALS-Kyber (for Key Encapsulation Mechanism) algorithms. These algorithms have been chosen by the National Institute of Standards and Technology (NIST) as winners in the competition for PQC Schemes.

During the period, following milestones have been achieved

- The development of CRYSTALS-Kyber and CRYSTALS-Dilithium on FPGA Platforms
- Design of Document Signer Application
- Development of PQC based Softoken
- Major features of CA Software suite adhering to IVG guidelines has been developed
- Development of PQC Enabled TLS-Cipher suite with tweaked PQC implementation.

## 9.1.4 Strategic Electronics & Strategic Initiatives

### Major initiatives and contributions in the domain of Strategic Technology

C-DAC has developed a range of high-reliability systems critical to the nation's Defence, Space, and Atomic Energy programs, ensuring the highest standards of performance and dependability. The following are C-DAC's major initiatives and contributions in the domain of Strategic Technology.

- C-DAC signed Memorandum of Agreement (MoA) for the Transfer of Technology (ToT) of the Indigenous Acoustic Gunshot Detection System with Sagar Defence Engineering Pvt. Ltd. during Tec-Verse 2025 event at Delhi.
- C-DAC successfully completed the bathymetry survey of two glacial lakes at 4800-meter ASL in Himachal Pradesh, braving hard trekking and climatic conditions, using an indigenously developed Autonomous Bathymetry Survey Vessel.
- C-DAC has developed the Multichannel Precision Instrumentation Amplifier (PRIAMP), which has been certified by ISRO for induction into their mission programmes for the Static firing Tests of Rockets

- C-DAC has delivered 76 units of the Speed Switch for Dornier aircraft to the Indian Defence Forces through HAL after receiving LoA certification from CEMILAC.
- C-DAC has developed Submarine Echo sounders installed on Navy submarines INS Sindhukirti and INS Arisudan (Nuclear class).
- C-DAC has delivered MIL-qualified simulators of the Navigational Suite to the Indian Navy, as part of the Integrated Combat Suite project for submarines, through DRDO labs – RCI and NPOL.
- C-DAC Thiruvananthapuram has indigenized the EM Log transducer for Indian Naval ships
- C-DAC has completed the Sea Acceptance Trial (SAT) of a Surface Buoy-based Noise measurement system for NPOL, DRDO. This is India's first installation to monitor submarines and other maritime threats from hostile countries.
- C-DAC has delivered an advanced Sonic Ultrasonic NDT system to ISRO Propulsion complex Mahendragiri; CAS-DRDO; and L & T Defence.
- The Integrated Electronic Warfare System (IEWS) developed by C-DAC in association with DLRL DRDO is an example of indigenous excellence in empowering India with advanced solutions in Defence and strategic domain. It is typically deployed across an area of 200 Square KM on the international borders. C-DAC has been developing this system for DLRL through multiple TRL projects like "Girishakti" and "Dharashakti" for the last 7 years, and has seen its appreciation in the recent "Operation Sindoor", where the system was put into use for empowering the defence forces in protecting Indian border from enemy advances.

#### **Centre for Excellence, MCTE, Mhow**

C-DAC has established Centre of Excellence (CoE) at MCTE, Mhow, Madhya Pradesh. This CoE aimed at driving research, development, and deployment of futuristic technologies that go beyond existing capabilities and to foster collaboration in research and development in niche technology domains with direct military applications which aims for the development of indigenous solutions under the Atmanirbhar Bharat and Digital India initiative.

#### **Digital Centre of Excellence in Maritime**

C-DAC's Centre of Excellence (CoE) in Maritime Technologies is set to drive innovation in smart maritime solutions, focusing on autonomous navigation, vessel monitoring, oceanographic data analytics, and marine cybersecurity. By leveraging advanced AI, IoT, and embedded systems, C-DAC aims to develop next-generation maritime communication systems, predictive maintenance solutions for ships, and real-time environmental monitoring tools.

#### **Centre of Excellence (CoE) for Products Based on Li-ion Cells (Post-Cell)**

The project "Establishment of Centre of Excellence (CoE) for Products Based on Li-ion Cells (Post-Cell)" is an initiative of the Government of India to boost the mobile and other electronic industries in the country. The project is being implemented by C-DAC Noida in association with the Industry Association – India Cellular and Electronics Association (ICEA) & financially sponsored by the Ministry of Electronics & Information Technology, Govt. of India, and the Department of IT & Electronics, Govt. of Uttar Pradesh.

#### **9.1.4.1 Intelligent Transportation Systems**

##### **CV2X - Hardware Adapter for Traffic (HAT) signal controller**

C-DAC has developed a C-V2X Hardware Adapter (HAT) for Traffic Signal Controller, a solution that upgrades existing traffic signal controllers for C-V2X-readiness. The adapter enables seamless communication between traffic infrastructure and vehicles, supporting diverse V2X use cases such as real-time traffic signal information dissemination,

emergency vehicle pre-emption, bus priority, pedestrian safety, Green Light Optimal Speed Advisory (GLOSA), and intersection collision avoidance.

### **The Adaptive Traffic Management System (ATMS)**

The Adaptive Traffic Management System (ATMS), developed by C-DAC, integrates three core components: the CUTE traffic controller, the TraMM-EnV monitoring and management software, and the CoSiCoSt-EnV adaptive control algorithm. Together, these solutions form a comprehensive suite that enhances urban mobility, reduces congestion, and enables scalable, intelligent traffic management. The product suite is being deployed through Technology Transfer (ToT) partners, with ongoing implementations in Bangalore, Gurugram, Delhi, Thiruvananthapuram, Chennai, and Nepal, in collaboration with M/s Onnyx Electronics, M/s Envoy Electronics, and M/s IBI Group.

### **Centralized traffic Emergency Access Routing with Signal Priority (ClearWay)**

ClearWay is an emergency vehicle priority management solution, developed as an offshoot of the Vehicle Tracking and Fleet Management Software (*FlexiFleet*). It ensures faster clearance at traffic junctions by leveraging GPS data, geofencing, and integration with traffic signal systems to create green corridors, reducing response times and helping save lives during the critical golden hour. With its cost-effective architecture, ClearWay avoids heavy infrastructure investments by using mobile applications and existing devices for vehicle onboarding, while offering a scalable and deployment model suitable for both small towns and large metropolitan cities.

### **NCMC & QR compliant Automatic Fare Collection (AFC) Back Office for Metro Rail Corporations**

National Common Mobility Card (NCMC) is an initiative of the Ministry of Housing and Urban Affairs (MoHUA) to achieve the objective of “One Nation, One Card” to cater to uniform standard interfaces for various sub-systems in transit systems such as Metro. C-DAC has designed NCMC interface specifications (Part IV-VII) and QR specifications, which were released and recommended by MoHUA for Nationwide adoption. To prove the efficacy of standards, C-DAC has in-house designed and developed NCMC and QR compliant Automatic Fare Collection System (AFCS) for metro operators. C-DAC’s AFC solutions are designed specifically for Indian conditions where heavy footfall are the norms. Developed AFC software is a State of the Art, Scalable, Modular, and highly secured one.

C-DAC has developed the solution for Chennai Metro Rail Corporation (CMRL) for implementing a QR and Open Loop Ticketing system based on NCMC and Account-Based Ticketing (ABT). The developed solution is already jointly tested at CMRL lab successfully and implementation at all the 60 stations of CMRL is expected very soon.

## **9.1.5 Solutions for Smart Cities**

### **9.1.5.1 Delhi Safe City Project**

The Safe City initiative, launched under the vision of the Ministry of Home Affairs (MHA), Government of India, continues to make significant strides towards enhancing public safety, especially in relation to women’s safety, through CCTV surveillance and advanced technological infrastructure. Phase 1 of the project is offered to Delhi Police for acceptance with following deliverables:

A fully operational Data Centre equipped with comprehensive IT and Non-IT infrastructure along with functional deliverables deployed which includes VMS, ICCV, FRS, PIU, ANPR, Video Analytics etc.

### **Advanced Metering Infrastructure (AMI) and Smart Energy Meters**

An Advanced Metering Infrastructure (AMI) along with the Smart Energy Meters have been developed by C-DAC. AMI is a two-way communication system that automates energy data measurement, collection, control, billing, and

analysis. It consists of the Head End System (HES), Meter Data Management System (MDMS), and Billing System, and communicates seamlessly with Smart Energy Meters (as per BIS IS16444), through Cellular (4G/LTE) network as per BIS IS15959. It enables utilities to monitor demand, detect outages, improve billing, and support dynamic pricing, while consumers gain detailed usage insights to reduce costs. AMI also supports renewable integration, remote operations, and contributes to building smarter, more sustainable utility networks.

## 9.1.6 Language Computing and Heritage Computing

### 9.1.6.1 Speech Enabled Multilingual Chatbot

C-DAC has developed a Speech Enabled Multilingual chatbot that takes input in both speech and text forms and provides responses in both speech and text forms. It understands the user's intent and provides responses based on the predefined answer, or it creates answers based on business rules, data, etc. It uses Natural Language Processing techniques to process language, enabling them to understand human speech. The system is capable of handling predefined common queries such as inquiries about business/product/service, tracking details/status, FAQs, etc. This system has been developed as a part of the 'Speech Technologies in Indian languages' sub-project under the Project titled 'National Language Translation Mission (NLTM): BHASHINI'.

### 9.1.6.2 EL-ILMT: English Language to Indian Language Machine Translation System

The English Language to Indian Language Machine Translation (EL-ILMT) project, supported by MeitY under the National Language Translation Mission (Bhashini), develops and deploys bidirectional translation systems between English and Indian languages—Hindi, Marathi, Gujarati, Odia, Kannada, and Malayalam. Designed as a service on the Bhashini platform, the system focuses on domains such as Governance and Policy, Science and Technology, Education, Health, and Agriculture.

### 9.1.6.3 Development of a Printed Text Recognition (PTR) System for Indic Languages

C-DAC has developed an end-to-end Printed Text Recognition framework for Bangla, Assamese, Odia, and Manipuri languages. This work has been undertaken as part of a consortium project under the National Language Translation Mission (Bhashini). Over 4-million-word images have been used to train the Optical Character Recognition (OCR) engines, ensuring high accuracy and adaptability to diverse text formats. The framework has been customized to process noisy inputs, two-column bilingual text, and historical records, enabling the generation of searchable PDFs. It has been deployed for digitizing Parliament debate records and Punjab Vidhan Sabha proceedings.

### 9.1.6.4 An Interpretable Unified Framework for Text-to-Text Translation among Indian Languages using Sanskrit-based Interlingua Representation

Under the National Language Translation Mission (NLTM) 'BHASHINI', C-DAC is working on a consortium-based project aim at developing a linguistically faithful and interpretable translation system for the translation of text among multiple Indian languages. The project proposes to use an Interlingua framework rooted on the traditional grammatical system of Sanskrit.

### 9.1.6.5 Digital Preservation and Online Portal for Encyclopedic Sanskrit Dictionary

C-DAC has collaborated with Deccan College Post-graduate and Research Institute (Deemed to be University), Pune for the project that comprises of development of technological solutions to digitally preserve existing dictionary volumes, create new dictionary volumes, build the Sanskrit dictionary database, and make it available through online search portal. The following technological solutions are developed as a part of this project:

- KoshaSHRI - Sanskrit Dictionary Article Authoring Tool (AAT) powered by a crowdsourcing framework that helps the creation of new articles in a collaborative manner and the Sanskrit Dictionary Editor (SDE), that helps in editing the articles.
- Sanskrit Font (named as Koshashri) a specialized font with various Vedic symbols & matching Roman diacritical & English characters along with typing keyboard tool is provided to the users.
- KoshaSHRI - Sanskrit encyclopaedic Dictionary portal contains the vocables and volumes of the Sanskrit dictionary, which is useful for Sanskrit Scholars, dictionary experts, linguists, Indologists, students, public etc.

## 9.1.7 Telemedicine Solutions

### 9.1.7.1 eSanjeevani- National Telemedicine Service

eSanjeevani, the National Telemedicine Service of India, is an innovative, indigenous, and cost-effective digital health platform developed by the C-DAC for the Ministry of Health & Family Welfare (MoHFW), Government of India. Recognized as the world's largest telemedicine initiative in primary healthcare, it has already enabled over 412 million consultations, underscoring its unmatched scale, inclusivity, and transformative impact on healthcare delivery.

Powered by a secure and scalable cloud infrastructure, eSanjeevani is designed to manage up to one million consultations per day while upholding the highest standards of patient confidentiality and data privacy. Its modern microservices-based architecture ensures seamless adaptability to varying workloads and guarantees uninterrupted service even during peak demand, making it a trusted backbone of India's digital health ecosystem.

The service has been implemented in two key variants:

1. eSanjeevani – Ayushman Arogya Mandirs (Provider-to-Provider Telemedicine): Enables doctors and specialists at hubs to deliver quality healthcare services to patients visiting Health and Wellness Centres (HWCs), particularly in rural, remote, and underserved areas, in an assisted mode.
2. eSanjeevaniOPD (Patient-to-Provider Telemedicine): Empowers citizens to consult healthcare professionals directly from their homes using smartphones, laptops, or other digital devices, enhancing accessibility, convenience, and patient-centric care.

From 1<sup>st</sup> January 2025 to 16<sup>th</sup> September 2025, eSanjeevani successfully catered to 82.53 million patients across the country. It is operational at 121,584 Health & Wellness Centres (HWCs) as spokes, supported by 15,621 hubs and 56 online OPD services. More than 34,562 healthcare professionals—including doctors, specialists, super-specialists, and frontline workers—actively provided services through the platform during this period.

Recognizing its impact, scalability, and robustness, the Ministry of Electronics & Information Technology (MeitY) has positioned eSanjeevani as part of the India Stack, offering it as a digital public good and a global model for telemedicine. By democratizing healthcare access and aligning with national health priorities, eSanjeevani embodies the government's vision of inclusive, affordable, and technology-driven healthcare for all, setting a global benchmark in digital health innovation.

### Mercury™ Nimbus Neo Suite

Mercury™ Nimbus Neo Suite is a 5G and cloud-enabled Telehealth solution offering Telemedicine, TeleICU, and EMR/EHR-centric teleconsultation that can scale from clinic to multi-hospital deployment scenarios. The solution offers reliable Telemedicine-related services by leveraging 5G connectivity., which was tested on 5G simulation environments and CEWiT, IIT Madras 5G testbed. The TeleICU / Telemedicine services are set up and continued for Odisha state, NTPC Ltd., and the Jammu division using Mercury™ Nimbus Solution.

### 9.1.7.2 Healthcare Solutions

#### 9.1.7.2.1 e-Upkaran

e-Upkaran is a comprehensive equipment maintenance and management system designed to manage the entire lifecycle of medical equipment deployed in health facilities across the states. The system aims to enhance monitoring, streamline processes, and accelerate workflows related to equipment procurement, complaint management, and utilization. By supporting data-driven decision-making, e-Upkaran enables more effective use of both existing and newly acquired medical equipment, ultimately helping states provide improved healthcare services to their citizens. As of now, e-Upkaran has been successfully deployed in 12 States and 1 Union Territory.

#### 9.1.7.2.2 e-Aushadhi

e-Aushadhi-DVDMS is a technology-driven initiative to improve distribution of drugs, vaccines, and sutures by leveraging computing power at low cost. The main aim of e-Aushadhi-DVDMS is to ascertain the pharmaceutical needs of various district drug warehouses such that all the required materials/drugs are constantly available to be supplied to the user district drug warehouses without delay and finally issuing drugs to the patients, who is the final consumer in the chain. Currently deployed across 19 States, 6 Union Territories, 6 Central Programs, 1 Ministry of Defence Program, and 2 Insurance Medical Services Programs in Andhra Pradesh and Telangana.

#### 9.1.7.2.3 e-Sushrut HMIS

e-Sushrut-HMIS (Hospital Management Information System) has taken a major leap this year. After successful completion of POC in the State of Tamil Nadu, Govt of Tamil Nadu has approved the state wide rollout of e-Sushrut HMIS and christened as TN-HMIS 3.0. Also, Government of Jharkhand has approved the state wide rollout of e-Sushrut HMIS in all type of Government Health Facility, with these addition C-DAC's e-Sushrut HMIS has now been rolled out in 11 States. With JIPMER Puducherry adopting e-Sushrut HMIS, C-DAC's super specialty implementation has increased to 20 as 17 AIIMS, PGIMER Chandigarh, NIMS Hyderabad already using e-Sushrut HMIS.

#### 9.1.7.2.4 Indian Railways – Empanelled Hospital Referral Portal (IR-EHRP)

After successful rollout of e-Sushrut HMIS in Indian Railways Health Facilities, Indian Railways has awarded C-DAC to develop a comprehensive system for managing the patient referrals from Railway Health Facilities to Private & Super specialty Government Hospitals and further integrating with Miscellaneous E-Receipts System (MERS) Payment Gateway of Indian Railway & UMID System (Unique Medical Identification System) of Indian Railways to bring the transparency. The system uses two factor authentication system to recognise employee. System has been made live in the May 2025 with approximately 1500 Indian Railways Empanelled Hospital onboarded on the IR-EHRP.

#### 9.1.7.2.5 Student Life Cycle Management System (SLCMS) For Medical College

e-SLCMS is a comprehensive software solution designed to manage the entire life cycle of students within medical colleges. The system covers various aspects of student information and administrative processes, from the initial application and admission through graduation/post-graduation and alumni tracking. The goal of a Student Life Cycle Management System is to streamline administrative processes, improve data accuracy and information sharing, enhance communication etc.

#### 9.1.7.2.6 SaQsham

C-DAC in collaboration with the National Health Systems Resource Centre (NHSRC) has developed and maintains a comprehensive digital platform titled “SaQsham” for Quality Certification of public health facilities across India. This platform manages the entire certification lifecycle, covering application submission, assessment workflows, document verification, automated scoring, and result declaration. It provides a centralized, role-based platform connecting hospitals, assessors, quality officers, and administrative authorities, ensuring seamless coordination and transparency

across stakeholders. The platform supports multiple certification types, including National Certification (NQAS), State-level Certification, Internal Assessments, Surveillance, and Re-Certification Processes.

#### 9.1.7.2.7 e-प्रत्यारोपण

C-DAC, in collaboration with National Organ and Tissue Transplant Organization (NOTTO), under the Directorate General of Health Services, Ministry of Health and Family Welfare (MoHFW), Government of India, has initiated prestigious e-प्रत्यारोपण project.

The initiative aims to deliver a digital platform comprising web and mobile applications to streamline the entire organ and tissue transplantation ecosystem. Key features include donor pledge registration, recipient registry management, and an automated organ allocation system ensuring fair, transparent, and rule-based distribution based on medical urgency and ethical norms. By bridging the gap between demand and supply, e-प्रत्यारोपण is expected to strengthen the national transplantation framework, improve efficiency, and bring significant benefits to citizens across India.

Once launched, the e-प्रत्यारोपण application will empower NOTTO to seamlessly serve its nationwide network comprising 5 Regional Organ & Tissue Transplant Organizations (ROTTOs), 25 State Organ & Tissue Transplant Organizations (SOTTOs), 1,050 authorized transplant and retrieval hospitals across India. The platform will also extend its benefits to millions of citizens, including individuals pledging to donate organs as well as patients awaiting life-saving transplants.

#### 9.1.7.2.8 Standards and Compliance

##### 9.1.7.2.8.1 Common Drug Codes for India (CDCI)

To support the standardized coding of medications in EHR, C-DAC has developed and released Common Drug Codes for India. CDCI is a set of files that integrates with SNOMED CT Global Medical Terminology files and content for use in any data entry, analysis, or record exchange in healthcare systems/applications.

During the period, CDCI has 03 releases on March 28, June 20, and September 18, 2025. The latest release of the extension, synchronous with the June 2025 SNOMED CT International Edition, has a total of 9625 Generic and 86498 Branded Medicines. This package, developed under the National Resource Centre for EHR Standards (NRCeS), is available in Terminology Integrated Package and Flat Files Package for use across healthcare records, supply, and pharmacy systems.

##### 9.1.7.2.8.2 FHIR Implementation Guide for Ayushman Bharat Digital Mission (ABDM)

The Fast Healthcare Interoperability Resources (FHIR) Implementation Guide (IG), developed by C-DAC, is a critical enabler of interoperability within the Ayushman Bharat Digital Mission (ABDM) for the National Health Claim Exchange (NHCX). It standardizes healthcare data structures and exchange protocols, ensuring consistent and secure sharing of information across diverse systems.

#### Key Achievements

- 13 releases of the IG have been published to date, reflecting continuous enhancement.
- Successfully supports ABDM data exchange and NHCX workflows.
- Adopted by 2,171+ ABDM integrators and 40+ insurance companies, demonstrating wide-scale implementation.

The latest release on May 08, 2025, introduced enhanced NHCX data exchange capabilities with profile updates and new Code Systems and Value Sets.

#### 9.1.8 Cyber Security

C-DAC has established itself as a trusted provider of cybersecurity products and services, particularly within the

government sector. C-DAC addresses the full spectrum of cybersecurity domains, including application security, cloud security, critical infrastructure protection, data security, endpoint protection. IoT security, mobile security, network security and cyber forensics. As a CERT-IN empanelled agency, C-DAC plays an active role in conducting audits and assessments to bolster national cyber resilience. Various solutions developed by C-DAC in this area are as below

#### 9.1.8.1 National Blockchain Framework

Technology stack for National Blockchain Framework is developed and is being used for developing applications for Govt. Departments. Various innovative applications such as Blockchain based service level training record solution for Sardar Vallabhai Patel National Police Academy (SVPNPA), Pilot deployment of Smart phone based Blockchain enabled e-Voting system for Bihar Nagarpalika election 2025, Domicile Verification System (DOVE) are developed and deployed using the National Blockchain Framework. Other applications that are developed and field deployments are ongoing include AURA VeriChain System and Mediproof: Medicine Verification through Blockchain.

NBFLite a light weight Blockchain platform is being used by 20+ startups / academia / industry for research, rapid application development, and training. A MeitY guided Startup Challenge efforts has been initiated towards onboarding 10 application through startups.

#### 9.1.8.2 Escrow Your Encryption Secret (EYES)

EYES is a tool strategically researched, designed, and developed by C-DAC. It has been indigenously built to help agencies defend against ransomware attacks and enable rapid system recovery. The tool employs critical and strategic mechanisms to recover the encryption keys used by ransomware during the attack phase, and subsequently leverages the same keys to decrypt compromised files. Beyond post-attack recovery, EYES also incorporates damage-control capabilities to halt ransomware at an early stage of file encryption. The initial phase of development has produced a Linux-compatible version, with a Windows version planned for the next phase.

#### 9.1.8.3 Generation of In-House Secure and Trusted Elliptic Curve (GHOST)

GHOST is an indigenously developed solution by C-DAC for generating elliptic curves of short Weierstrass form over arbitrary prime field sizes for scalable security in a transparent and well explained manner. Designed for strategic applications, it uses novel algorithms and trust evaluation criteria to ensure curves are both cryptographically secure and trusted, supported by mathematical proofs, validations, and comprehensive technical reports. GHOST offers elliptic curves up to 768-bit prime fields, the highest reported in literature, with features including security and trust evaluation of GHOST as well as foreign curves, prediction of computational investment required in randomly drawing elliptic curve, and insights on quantum attack resiliency. These curves are suited for PKI, TLS, SSL, authentication, digital signing, standardization, RNG development, and proprietary protocols, with comprehensive documentation and transparent source code. C-DAC's Param Buddha HPC facility has been extensively used in the generation and testing of GHOST curves. GHOST curves power indigenously platforms such as the Lakshman PKI, strengthening India's cryptographic self-reliance.

#### 9.1.8.4 C-DAC-Intelligent Malware Sandbox

To combat the rapidly evolving malware threat landscape, C-DAC has developed an indigenous solution called the "C-DAC Intelligent Malware Sandbox (CIMS)." This advanced framework integrates multiple techniques for malware detection and classification, including signature-based behaviour analysis, code DNA sequence analysis, and artificial intelligence (AI). Unlike conventional approaches that depend heavily on expert-driven reverse engineering through debuggers and disassemblers or on resource-intensive dynamic execution, CIMS can characterize malicious programs with minimal manual intervention. It is capable of detecting and classifying malware across diverse platforms, including

Microsoft Windows, Linux, IoT, and SCADA systems. As the first framework of its kind, CIMS is already being actively deployed in several nationally significant projects, significantly enhancing the nation's cyber defence capabilities.

#### 9.1.8.5 CDACSIEM

The CDACSIEM Solution features a data aggregator that collects vast amounts of log data from across the entire network environment, normalizes it, applies analytics, consolidates information, and delivers comprehensive security visibility to SOC analysts.

Key functionalities include log collection and real-time monitoring, dashboards and visualizations, anomaly detection, correlation engine, endpoint detection & response, MITRE ATT&CK framework mapping, threat intelligence integration (30+ threat feeds), user entity and behaviour analytics (UEBA), compliance reporting (covering NIST, HIPAA, and ISO 27001 standards), asset discovery and management, automated vulnerability scanning, ticket management system, log retention and archiving.

Recent deployments of the CDACSIEM Solution include Liquid Propulsion Systems Centre/ISRO (Trivandrum & Bangalore), Madhya Pradesh Paschim Kshetra Vidyut Vitaran Company Ltd. (Indore), Madhya Pradesh Poorv Kshetra Vidyut Vitaran Company Ltd. (Jabalpur), Madhya Pradesh Madhya Kshetra Vidyut Vitaran Company Ltd. (Bhopal), Jawaharlal Nehru Port Trust in Mumbai, and the National Skill Development Corporation Limited in New Delhi.

#### 9.1.8.6 GANGA

GANGA is an indigenously developed Cryptographically Secure Pseudo Random Number Generator (CS-PRNG), designed as a kernel module for operating system kernels. It possesses a distinctive capability to generate non-reproducible random bitstreams that are cryptographically secure. GANGA produces random bitstreams of arbitrary length that are unpredictable and resilient against modern cryptographic attacks. Its design is backed by formal proofs that mathematically guarantee its security and trustworthiness. GANGA has undergone rigorous benchmarking against existing popular kernel RNGs and has successfully passed all statistical tests from the NIST, Diehard, and TestU01 test suites. Additionally, it has been subjected to comprehensive security analysis to assert its cryptographic security. Through its unique design, GANGA achieves ideal Shannon entropy (1.0) and surpasses existing generators in terms of linear complexity, period length, key space, and statistical randomness, all while maintaining a lightweight kernel footprint.

GANGA can be integrated as a kernel object into Linux-based operating systems such as BOSS, Ubuntu, and Debian. It can also function as an independent application for integration into other systems. Since 2024, GANGA has been deployed by the Indian Army, marking a significant milestone in India's pursuit of technological self-reliance under the Make in India and Atma Nirbhar Bharat initiatives.

#### 9.1.8.7 Lakshman- A Secure and Trusted Public Key Infrastructure (PKI)

Lakshman is a strategic Public Key Infrastructure (PKI) solution to deliver secure, reliable, and policy-driven certificate-based communication for enterprise and mission-critical environments. Built on GHOST elliptic curve cryptography, it provides a strong cryptographic foundation, advanced trust-based architecture, and strategic key management to simplify complex PKI administration while ensuring compliance with stringent security policies. With best-in-class benchmarks in both performance and security, Lakshman is tailored for high-assurance use cases in defence, intelligence, and government ecosystems, including the Indian Army, Navy, Air Force, law enforcement, and agencies under the Ministry of Home Affairs. Its scalable, industry-grade design addresses the nuanced requirements of sensitive applications, making it a trusted foundation for secure digital identity and communication across India's critical infrastructure.

## 9.1.9 Cyber Forensics

### 9.1.10.1 Establishment of Cyber Forensics Labs

C-DAC has been entrusted with establishing a full-fledged Cyber Forensics Laboratory at FSL Jammu and upgrading the existing facility at FSL Srinagar. As part of the scope, C-DAC has installed and commissioned a comprehensive suite of cyber forensic hardware and software tools including C-DAC developed in-house solutions and third-party forensic tools, high-end cyber forensic workstations, servers, and the necessary laboratory infrastructure equipment. In addition, C-DAC has provided hands-on training for the effective usage of these tools, along with support and maintenance services for a period of three years.

### 9.1.9.2 Design and Development of Advanced Forensics Data Analytics Tool

As a part of this project, C-DAC is developing 3 new tools in the domain of Forensics Data Analytics, FinTech Forensics, and IoT Forensics. Enhancements of the existing Cyber Forensics tools are also in progress. The mobile phone Forensics software tool suite is enhanced to support more number of Android mobile phone and drones.

## 9.1.10 Software Technologies including FOSS

### 9.1.10.1 MeriPehchaan

Details are covered in Chapter 2.

### 9.1.10.2 Aadhar Data Vault (ADV) as a service

Details are covered in Chapter 2.

### 9.1.10.3 e-Hastakshara: An Online Digital Signing Facility (C-DAC's e-Sign Service)

Details are covered in Chapter 2.

### 9.1.10.4 Vikaspedia 2.0

Details are covered in Chapter 2.

### 9.1.10.5 CMPFO's Centralized Claim Processing & Settlement System (C-CARES) 2.0

C-CARES has digitally revolutionized the working of Coal India Limited (CIL) subsidiaries and Coal Mines Provident Fund Organization (CMPFO) by digitalizing and automating the claim settlement processes at the respective organizations. It is first-of-its-kind implementation for CIL & CMPFO. C-CARES 2.0 completes the entire Claims Settlement cycle by the implementation of Financial Module that provisions the credit of settlement amounts directly from C-CARES Platform to the subscribers bank account.

### 9.1.10.6 Design and development of Judicial Digital Preservation System (JDPS)

A project funded by committee, Supreme Court of India through Ministry of Law & Justice (Department of Justice) has been initiated for design and development of Judicial Digital Preservation System (JDPS) focussed towards the digital preservation requirements of the Judicial establishments in India. Digital Preservation Resource Centre (DPRC) is envisaged to emerge as a resource of technology solutions, standards, and best practices for the Indian Judiciary under this project.

### 9.1.10.7 eGovernance Standards and Guidelines

C-DAC and Standardisation Testing and Quality Certification (STQC) Directorate have been entrusted to develop/review ICT standards, guidelines, and/or frameworks for e-Governance projects along with proliferation of MeitY notified standards and guidelines so far.

- The draft guidelines documents on topics namely Mobile Security Guidelines (MSG), Guidelines for Internet of Things (IoT) Security, Guidelines for Zero Trust Architecture (ZTA), Enterprise Architecture (EA) Security were submitted to BIS for further notification/publication.
- The draft guidelines documents on topics namely Guidelines for Anonymization of Data (AoD), Metadata and Data Standards of Education, Metadata and Data Standards of Logistics were submitted to AI & ET Division, MeitY for notification and publication.
- The drafting of the standard/guideline documents for Online Learning and Examination System (OLES), Metadata and Data Standards of Agriculture, Microservices, Sandbox Testing, Enterprise Risk Management, Two Factor & Multifactor Authentication, and Interoperability framework for e-Governance (revision) is under progress.

### 9.1.11 Free and Open-Source Software (FOSS)

Enterprise BOSS Linux has been rolled out across PAN C-DAC. Secure BOSS Linux has been revamped and deployed for clients in the Indian Navy and Indian Army, migrating over 15,000 machines. Secure BOSS Linux has been launched for the Indian Army Terrifier Cyber Quest 2025, a national-level challenge addressing real defence and cybersecurity threats. To counter emerging threat vectors advanced security features have been integrated into Secure BOSS Linux deployments within the defence sector. C-DAC has developed the next version of Secure Exam OS, enabling secure online examinations for over 25 lakh candidates.

#### 9.1.11.1 Neuromorphic Computing

C-DAC Chennai and MeitY have organized a Brainstorming Session on Neuromorphic Computing on April 16, 2025, with participants from 18 prestigious institutes of national importance, including IITs and IISc, attracting around 40 attendees. The session covered various ongoing activities in Neuromorphic Computing across academic and research institutes. Based on the insights from brainstorming session, key work themes and action plan have been identified in collaboration with the participating institutions. A joint proposal involving respective academic institutes and R&D organizations is being prepared for development of India's first Neuromorphic Chip.

### 9.1.12 Capacity Building Initiatives

#### 9.1.12.1 Information Security Education and Awareness (ISEA)

Details are covered in Chapter 7.

#### 9.1.12.2 Future Skills PRIME

Details are covered in Chapter 7.

#### 9.1.12.3 SwaYaan- Capacity Building for Human Resource Development in Unmanned Aircraft Systems/Drone & related technology

Details are covered in Chapter 7.

#### 9.1.12.4 Work Based Learning Programme (WBLP)

Details may be seen at Chapter 7.

### 9.1.12.5 Cyber Gyan- A Real-Time Cyber Security Scenario-based Self-Paced Learning Training Facility

Cyber GYAN, was launched in February 2022 to provide specialized cybersecurity training for SC, ST, and Economically Weaker Section undergraduate and postgraduate students, as well as faculty members from government colleges across India. The project aimed to establish a Self-Paced Learning Training Facility focused on enhancing cybersecurity skills within the academic community.

As part of this initiative, A Self-Paced Learning Training Facility with 100 simulated automated real-time cyber-attack scenarios based on modern tools and techniques have been developed. These scenarios provide participants with a practical understanding of cyber defence mechanisms in an immersive, yet controlled and realistic setting. The project successfully completed on 3rd August 2025, achieving all its objective. Total 538 faculty members and 6309 students were trained under the project demonstrating the project's far-reaching impact in building a skilled and informed workforce in cybersecurity.

### 9.1.12.6 Cyber Shakti: Empowering Women Government Officials in Cyber Security

The project "CyberShakti: Empowering Indian Women Government Officials in Cyber Security" is being implemented by C-DAC with the focus on cyber security education of women Govt officials using real time cyber-attack based scenarios to provide them experiential learning of cyber-attacks in a virtual environment. The project aims to equip women officials from central Govt, state Govt and PSUs across India are invited to attend the programmes with the necessary skills to work as a member of cyber security team in their respective organizations.

The training and assessment are conducted using modern day tools and technologies including real time cyber-attack-based exercises using red team and Blue Team activities, Capture the Flag, Table top exercises, and Cyber Drill exercises. More than 900 government women officials have been benefitted through various online and offline training programmes and workshops under the project.

## 9.1.13 Education and Training

### 9.1.13.1 PG Diploma courses in ICT

C-DAC is conducting 900 hours duration of training courses in 14 advanced ICT domains for Engineering graduates and Science Post Graduates. C-DAC has trained over 6600 students through the PG Diploma courses in ICT and have successfully completed the courses through the network of training centers across India. Approximately 3628 students are inducted in the PG Diploma Courses in ICT domain in August 2025 batch who will be qualifying by Feb 2026.

The six (6) IT domains in which the students are undergoing training includes Software Development, Electronics and Software, Data Science & AI, Security & Blockchain and HPC domain.

Capacity building in High Performance Computing (HPC) for 241 candidates of Scheduled Caste and Scheduled Tribe communities through two Post Graduate Diplomas in HPC domain have completed the training.

Drone and Allied Technologies specialized programme is conducted by C-DAC for building capacity through Post Graduate Diploma in Unmanned Aerial System programming.

C-DAC has signed an MoU with Academy of Maharashtra for Research, Upliftment and Training (AMRUT) Government of Maharashtra for sponsorship of the communities of Maharashtra from Economically Weaker Sections for skills, entrepreneurship development, imparting advance training. Under this scheme, students are undergoing the training in PG Diploma Courses and Certificate Courses in ICT domain. 53+ students from the EWS communities have been sponsored by AMRUT, Pune.

### 9.1.13.2 OLABs NextG: Next Generation Online Labs (OLABs) for schools

Details are covered in Chapter 7.

### 9.1.13.3 Process Automation for Competitive Examinations (PACE)

PACE has been involved in major Indian exams since 2013, such as the IIT-JEE Advance result processing and counseling, JEE-Mains counseling, GATE since 2013, JAM since 2015, AIIMS PG/MBBS counseling from 2018 to 2021, and NBE (National Board of Examination) seat counseling since 2019.

Since January 2025, PACE has successfully completed:

- Graduate Aptitude Test in Engineering (GATE 2025): Result processing and scorecard generation for 9.5 lakh candidates.
- Joint Admission Test for Masters (JAM 2025): Result processing, scorecard generation, choice filling, and seat counseling for 60 thousand candidates.
- National Board of Examinations (NBE): Seat counseling for 300 seats for NBE's DNB/PDCET/DNB (POST MBBS).

### 9.1.14 North East Initiatives

- Under the Centre for HPC Upskilling and Knowledge Sharing (C-HUK) Project, the 3rd Advanced Computing Course (ACC) was successfully conducted from March to August 2025. The 4th ACC commenced in August 2025 and is scheduled to conclude in March 2026.
- As a part of Post Graduate Diploma in Artificial Intelligence (PG-DAI), 14 participants have completed the program during February 2025 batch.
- At C-DAC Centre in North-East, a total of 38 candidates has been enrolled, of which 27 have successfully achieved certification under Work-Based Learning (WBL) Internship Program.
- As a part of Project titled "Empowering Police Personnel and Government Officials of N.E States" C-DAC Centre in North-East has successfully conducted five Cyber Security Awareness Programs (6-hours), certifying 1,366 Police and Government Officials, and eight Intermediate Cyber Security Training Programs (20 hours), certifying 177 participants.
- C-DAC Centre in North-East has been awarded a project titled "Website Custom Service Hosting Management Maintenance and Certifications" of National Institute of Design (NID), Assam.
- C-DAC Centre in North-East has entered into a Memorandum of Agreement (MoA) with the Health and Family Welfare Department, Government of Sikkim, for the implementation of the Drugs and Vaccine Distribution Management System (DVDMS) project in the state.
- C-DAC Centre in North-East received projects from the Health and Family Welfare Department, National Health Mission, Government of Sikkim, in the month of March 2025 for the implementation and maintenance of the e-Sushrut Hospital Management Information System (HMIS).
- As a part of Information Security Education and Awareness (ISEA) program, C-DAC Centre in North-East has been identified as one of the co-lead centres, responsible for developing selected training modules, implementing virtual labs, creating a question bank, and conducting CISO training through a hybrid mode. Through this program, approximately 45,000 professionals are expected to be trained or certified over a five-year period.

## 9.2 Society for Applied Microwave Electronics Engineering and Research (SAMEER)

### 9.2.1 Introduction

The Society for Applied Microwave Electronics Engineering and Research (SAMEER) is an autonomous R&D institution under the Ministry of Electronics and Information Technology (MeitY), Government of India. It was formed in 1984 as an R&D Laboratory of the then Department of Electronics, Government of India with an objective to support the various Radio frequency (RF) and Microwave application specific requirements of the different ministries of the Government of India. SAMEER has five centres located in Mumbai, Chennai, Kolkata, Visakhapatnam and Guwahati. The headquarters of SAMEER is located at IIT campus, Powai, Mumbai.

SAMEER undertakes various state-of-the-art and challenging projects from HF to photonics with the aim of remaining at the forefront in the various microwave and millimeter wave domains including (but not limited to) the linear accelerator technology, atmospheric radars, microwave heating and drying, photonics, microwave communication, 5G and 6G communication systems, quantum technology and other such applications. SAMEER also designs and develops passive and active components and subsystems such as amplifiers, antennas, digital receivers, transceivers, etc. The research findings and results are regularly documented and reported in reputed journals and conferences by SAMEER scientists.

SAMEER also offers test and measurement services in Electromagnetic Interference & Compatibility (EMI/EMC), antenna performance measurement services, shielding effectiveness evaluation of chambers, calibration services for different electronic equipment and testing of equipment to safety standards to support private industries and government agencies of the country in qualifying their products as per various national and international standards.

### 9.2.2 SAMEER Centres

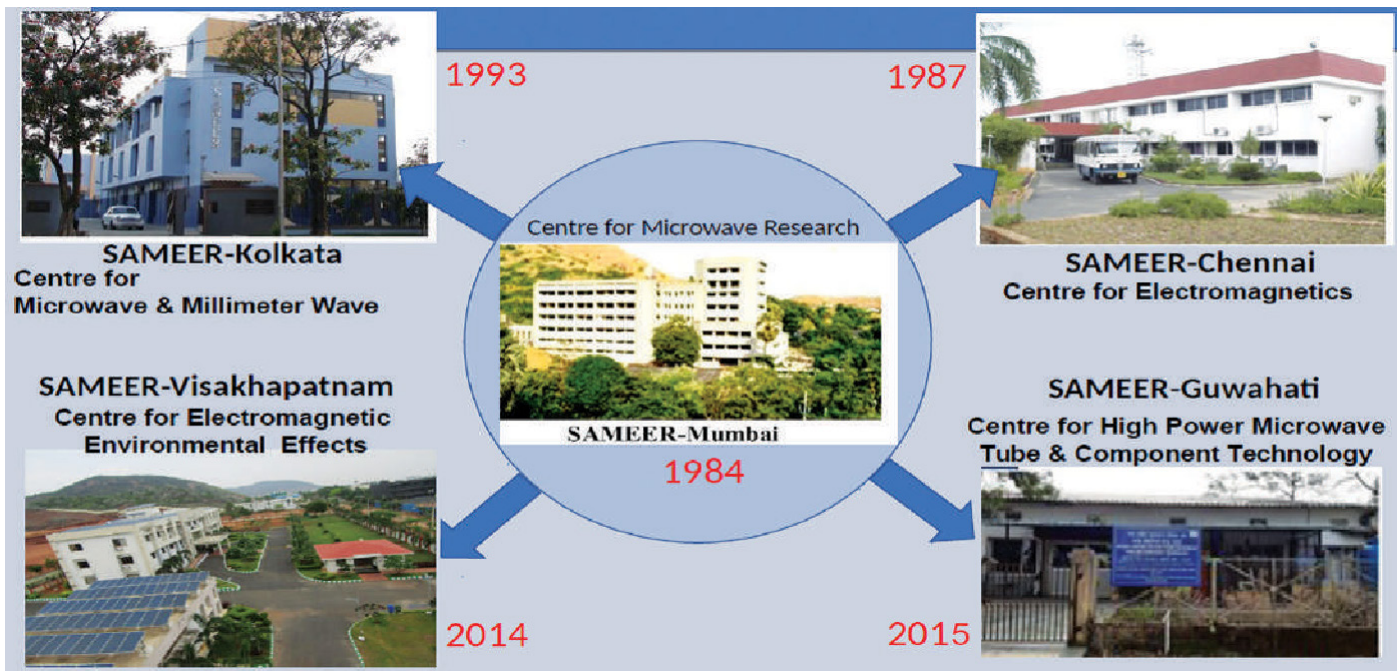

SAMEER Centres

## 9.2.3 R&D Activities

### 9.2.3.1 NexGen Technology

#### 9.2.3.1.1 Research in Bharat 6G

- 6G: Sub-THz Wireless communication with Intelligent Reflecting Surfaces (IRS)

The objective of this new technology demonstration project sponsored by MeitY is to exhibit a fully functional 6G high speed communication link incorporating various sub-systems at 140 GHz under the Atma Nirbhar Bharat Mission. SAMEER is executing this project with IIT Madras as a consortium member. SAMEER successfully demonstrated a Line-of-Sight (LOS) link with 6.4 Gbps Data Transmission speed.

Another objective of the present project is to demonstrate intelligent reflecting surfaces (IRS). SAMEER has designed and developed a functional IRS at 7GHz and demonstrated non-specular reflections at various angles during India Mobile Congress 2025. A suitable IRS controller has also been designed and developed for 1-bit IRS demonstration. The operational frequency is tunable, and it demonstrates non-specular reflections at various angles.

- 6G: THz Test bed with Orbital Angular Momentum and Multiplexing**

This 6G project is sponsored by the Department of Telecommunications (DoT) and the primary objective of the project is the design, development and deployment of an end-to-end 6G Test bed. The test bed is being implemented by SAMEER jointly with three other IITs. 6G 6.4 Gbps simplex data transmission at 283GHz was demonstrated at SAMEER Stall during the India Mobile Congress 2025 using indigenously developed millimeter wave subsystems.



(a)



(b)



(c)

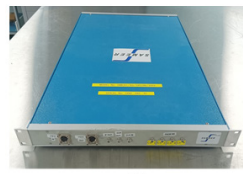

(d)

- (a) Indigenously developed J-band transmitter
- (b) Indigenously developed J-band receiver
- (c) Indigenously developed 4-channel IF Up-converter
- (d) Indigenously developed 4-channel IF Down-converter

#### 9.2.3.1.1 Indian Defence Indigenisation

- Sensor Payload for Helicopter Landing Aid Technology under Diffused Visual Environment**

The objective of the project is to design and develop a W-band sensor payload deployable in helicopter under brownout conditions. The sensor measures the range and drift velocity of the helicopter under brownout conditions. A prototype sensor payload is developed at W-band in Frequency Modulated Continuous Wave (FMCW) configuration. The functionality of the prototype has been demonstrated using a drone.



**Prototype sensor payload mounted on drone platform**

### 9.2.3.2 Societal Applications

#### 9.2.3.2.1 Indigenous Magnetic Resonance Imaging System (IMRI)

The IMRI Mission program was launched in December 2014 with the goal of designing, developing and testing an indigenous 1.5 Tesla MRI System for medical imaging. The program has made significant progress. All the sub-systems including the High-Power RF Amplifier, Digital Spectrometer, Various Types of RF coils, Front End system, Control Monitoring and Interlock System, highly complex Reconstruction Software, Pulse Sequences and GUI has been successfully developed. Prototypes of these sub-systems are now ready for conversion into deployable products. 1.5T Superconducting Indigenous Magnet is currently in its final stages of development.

All the indigenous sub-systems, namely, 15 kW RF Amplifier, various types imaging RF Coils, FPGA-based digital Spectrometer, Couch system, monitoring and control systems and an imaging module for reconstruction and pulse sequence generation have been successfully designed and developed. All these sub-systems are mature enough to be taken for manufacturing. Currently, for System I, all these indigenously developed sub-systems have been

successfully integrated with the procured magnet and gradient system. Images have been obtained for phantoms, fruits, animals, and human volunteers and preliminary animal trials have been completed. Test License for this system has been obtained from Central Drugs Standard Control Organisation (CDSCO) regulatory body. Currently human trial is being done on this system. This system is planned to be deployed at AIIMS, New Delhi for Clinical validation. For System II, the Indigenous whole body superconducting magnet is in its final stages of completion. SAMEER has already developed all other indigenous sub-systems in collaboration with third parties, using know-how provided by SAMEER. Another 1.5T IMRI system would be developed once the magnet gets ready.



Indigenously developed MRI

#### 9.2.3.2.2 Research and Development of High Energy Linear Accelerator (LINAC) (HEL) for Medical and Other Applications

Scientists at SAMEER are attempting to accelerate electrons till 30 MeV with a very high beam power. This high energy LINAC will be immensely useful for medical applications like isotope research and development as well as neutron imaging and other industrial applications. The entire system is now integrated and vacuum processing is on-going. A stable beam is achieved and upgradation of energy will be attempted soon.

#### 9.2.3.2.3 High energy 30MeV linear accelerator (LINAC):

The objective of the project is to design and develop a high energy electron LINAC. The proposed LINAC will generate Medical radioisotopes (Molybdenum-99) which will be used to elute radioisotope Technetium (Tc-99m).

It is envisioned that the High Energy LINAC (HEL) would produce radioisotopes which would then be transported to hospitals for medical diagnostics, industrial applications or for non-destructive testing in strategic sector. The advantages will be production of radioisotopes without involving hazardous, explosive or fissile materials, almost no nuclear waste and with normalized capital costs.

This HEL promises transformative applications in medicine, including radioisotope research and development, neutron imaging, and various industrial uses. The system has been fully integrated, and vacuum processing is currently underway.

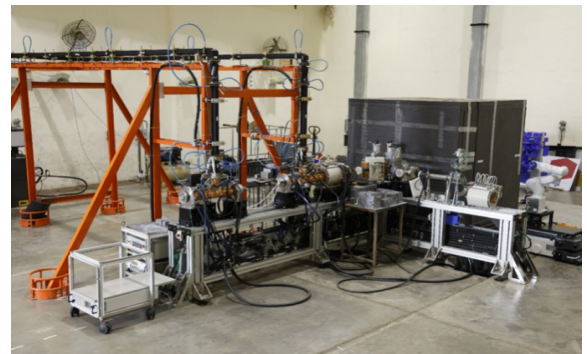

Installed LINAC systems under going vacuum processing

The control system for the entire accelerator complex has been designed and developed by the SAMEER team and is now fully operational. Hardware functionality tests have been successfully completed, and the integrated console is capable of synchronising all devices, managing interlocks, and coordinating with all sub-systems.

#### 9.2.3.2.4 Self-contained X-ray Blood Irradiator System

The Self-contained X-ray blood irradiator system uses high-dose X-rays to irradiate blood products, which helps prevent transfusion-associated graft versus host disease (TA-GVHD) in immuno-compromised patients. Two units of self-contained X-ray blood irradiator system have been developed by SAMEER with the financial support from MeitY. The system is safe, reliable, has a consistent high dose rate, and is completely shielded, eliminating the need for radioprotection measures. The electrical safety testing is completed/passed and certification obtained. The Atomic Energy Regulatory Board (AERB) authorization has been obtained by SAMEER as authorized supplier of X-ray Blood Irradiation System. The CDSCO test license has also been obtained. All the requisite AERB Radiation safety QA tests have been completed and submitted for AERB type approval. After obtaining AERB type approval, the indigenous Self-contained X-ray blood irradiator system will be installed at user hospital site.

#### 9.2.3.2.5 Atmospheric and Meteorological Systems

SAMEER is involved in design and development of atmospheric instruments for more than three and a half decades. By keeping an eye on the importance of the highly resolved meteorological measurements in space and time with large coverage, both in horizontal and vertical extents of atmosphere, SAMEER has developed expertise in both Acoustic and Radio waves based in-house instrumentation. Its work spans five major domains, viz., Radar based atmospheric remote sensing systems, Radiosonde & sounding systems, passive remote sensing instruments, Space weather study instruments and IT based atmospheric data processing solutions.

#### 9.2.3.2.6 Millimeter Wave Radiometer

The Millimetre Wave Radiometer consists of K-band (22GHz-30GHz) and V-band (50GHz-60GHz) receivers with dual band lens antenna, STM32 controller based motor control & data acquisition system & PC based post processing software to retrieve the continuous Temperature and Humidity profile of the atmosphere. The radiometer has been designed, developed, and installed at IMD Guwahati. The scientific data validation is carried out successfully matching with the Radiosonde data. The system is operational 24x7 at site.



K & V band Radiometer

### 9.2.4 Services

#### 9.2.4.1 Testing and calibration services

SAMEER Centres have provided service to the industry for EMI/EMC testing and consultancy related to military and civilian standards, calibration of test and measurement equipment, antenna pattern measurement and safety and environmental qualification of products to various national and international standards. The quality of testing and calibration is ensured by acquiring and maintaining NABL accreditation for EMI/EMC, Calibration and Safety and Environmental labs in SAMEER.

### 9.2.4.2 Radio Frequency Interference (RFI) Testing of Bharat Heavy Electricals Limited (BHEL) Make Non-AC Electric Multiple Units (EMU)

Radiated Emission of BHEL make EMU was performed at Gopal Nagar on Ranaghat to Bangaon railway line in Stationary mode and Slow moving mode (Traction & Braking mode).

### 9.2.4.3 Electromagnetic Compatibility (EMC) Consultancy

- **EMP Expert Consultant for High-Altitude Electromagnetic Pulse (HEMP) Facility Building for its Strategic use in Indian Air force**

SAMEER is a part of prestigious project in which, for the first time in the country, HEMP-hardened structures are being constructed for strategic applications. SAMEER was engaged in the project as an expert consultant for EMP, beginning from the design stage and continuing through installation. The acceptance and qualification of the HEMP filters and the shielded structures of the facility were evaluated and vetted by SAMEER as domain experts.

- **EMC Consultancy and Qualification of EMI Shielded Door for Naval Ships – Achieving 60 dB Shielding Effectiveness (10 kHz–40 GHz)**

The EMI Shielded Door developed by NAVSYS Marine Technologies, Hyderabad, was assessed, and technical inputs were provided through EMC consultancy to ensure compliance with stringent defence standards. The design objective of achieving 60 dB shielding effectiveness across a wide frequency range of 10 kHz to 40 GHz was successfully met by the door, ensuring reliable protection for naval applications.

## 9.3 Centre for Materials for Electronics Technology (C-MET)

Centre for Materials for Electronics Technology (C-MET) has been set up as a registered scientific society in March 1990 under Ministry of Electronics and Information Technology, (MeitY), (formerly known as Department of Electronics, DoE) as a unique concept for development of viable technologies in the area of materials mainly for electronics with the objectives of;

- To establish the technology up to pilot-plant scale for a range of electronic materials and transfer the same to industry for commercialization.
- To establish relevant advanced analytical facilities.
- To undertake applied research activities in the area of its operation.

### 9.3.1 Core competence at C-MET laboratories

C-MET's R & D activities have been implemented in three laboratories located at Pune, Hyderabad and Thrissur. C-MET headquarter is functioning at Pune Laboratory Campus, which monitors the administrative activity and central technical coordination of C-MET R&D activities. Each of these laboratories has its own area of specialization with requisite infrastructure and expertise. This approach has proven to be successful in creating core competence at each laboratory.

#### A. Pune laboratory

Pune laboratory is mainly focused on cutting edge R&D on materials for electronic packaging, renewable energy, energy storage, sensors and nano-materials/composites. These key areas of research have been thrived out into various interdisciplinary applications. Additionally, C-MET Pune has established Centre of Excellences in Rechargeable Battery Technology (CoERBT), Additive Manufacturing (CoEAM), National Centre on Quantum Materials (NCQM) and National Centre on Quantum Accelerator Chips (NCQAC).

## B. Hyderabad laboratory

C-MET, Hyderabad, has evolved as a national hub for research and technology development in advanced materials, especially those critical to strategic and electronic applications. Recognizing the importance of self-reliance in critical raw materials (CRMs), rare earth elements (REEs), ultra-high purity (UHP) metals, and wide bandgap (WGB) semiconductors, C-MET Hyderabad has invested significantly in building comprehensive laboratory infrastructure, specialized R&D units, pilot-scale facilities, and state-of-the-art instrumentation. This combination of capabilities enables C-MET to undertake end-to-end development starting from processing of raw materials to fabrication and evaluation of functional devices, while supporting scale-up and transfer of technologies to user agencies and industry. C-MET Hyderabad laboratory embraces unique R&D facilities, one of its kinds in the country for purification of metals to 99.99999 % (7N grade). A state-of-the-art SiC single crystal growth facility has been established, achieving a significant milestone by successfully growing 2-inch diameter semi insulating 6H SiC boules. The facility is further equipped for the growth of large-diameter SiC single crystal boules up to 6 inches to cater to the demands of power electronics and strategic device applications.

One of the key differentiators of C-MET Hyderabad is its robust pilot-scale and production infrastructure that enables seamless translation of lab-scale research into industrial processes. Among the most strategic of these is the Hafnium (Hf) production plant, which has been established with an annual production capacity of 320kg. This facility, recognized as the sole establishment of its kind within India, is designed to extract high-purity hafnium metal from intermediate zirconium-hafnium feedstock through the application of solvent extraction and metallothermic reduction methodologies. The purified Hf metal is used in aerospace alloys for space applications and supplied directly to ISRO and other strategic sectors. The entire process is backed by in-house Q Acertification using various characterization techniques, making C-MET the sole supplier of aerospace-grade Hf.

## C. Thrissur laboratory

The focus of C-MET Thrissur is in the development of materials and devices encompassing Sensors and Actuators, 2D materials, Microwave materials, Energy materials and storage devices, piezo electric materials and Plasmonic materials for electronic applications. In addition, the two national programs being implemented are i) Centre of Excellence on IoT based sensors, and ii) India Innovation Centre for Graphene (IICG). CMET Thrissur has gained expertise to develop customised IIoT sensors and deployed them for field trials. It has championed the art of making multi stacked capacitors and actuators are catering to the requirement of strategic sectors. Thrissur laboratory also meeting requirement of health sector in the form point of care devices based on plasmonic sensors, thermal sensor based early warning cancer devices and indigenously developed ultrasound probe.

Various reputed organizations such as DRDO, ISRO and DAE institutions and other private industries/start-ups have joined hands with C-MET through Memorandum of Understanding (MoUs) to facilitate collaborative activities. These meaningful associations exemplify C-MET's dedication towards encouraging innovation, knowledge exchange, and progress in diverse fields through joint efforts.

### 9.3.2 Products developed by C-MET for different applications

- 3D printed pouch cell and coin cell
- 3D design and printed package of POC 4 (Optical coupler for opto-electronic packaging) and POC 5 (Ring resonator)
- Carbide derived carbon (CDC)
- Polybutadiene based Substrate Integrated Waveguides (SIW) for microwave and millimetre wave circuit applications
- Tri-band composite NavIC Antenna

- 7N Zinc for detector applications
- Purification of scrap Germanium to 7N Germanium
- Hafnium sponge for space applications
- Li-Ion Battery Recycling: Hydrometallurgical route
- Li-Ion Battery Recycling: Pyrometallurgical route
- Extraction of REE from end-of-life Permanent magnets: Hydrometallurgy route
- Planar Plasmonic Film for Sensing Device Applications
- Humidity/Temperature sensor Module with Zigbee communication
- Wi-Fi enabled temperature module for cold storage and perishable food and medicine supply
- Soil moisture sensor
- Anti corrosion coatings using graphene
- Nano silver screen-printable ink for flexible electronics applications
- Silver screen-printed RFID tags technology for NFC applications
- Graphene based transparent acoustic sensors and actuators
- Multilayer piezo actuators
- CO<sub>2</sub> smoke and RH sensors

### 9.3.3 Technologies transferred to industries:

#### 9.3.3.1 The Li-ion battery recycling technology developed under CoE on E-Waste Management is transferred (ToT) to nine (9) industries.

- ToT to M/s Magnifiq Services Pvt. Ltd., Hyderabad, Telangana on April 15, 2024
- ToT to M/s Amare & Alate Construction Pvt. Ltd., Kochi, Kerala on May 6, 2024
- ToT to M/s Nile Li Cycle Pvt. Ltd, Hyderabad, Telangana on May 17, 2024
- ToT to M/s. Back to Basics recycling Pvt. Ltd., Delhi on July 8, 2024
- ToT to M/s. Navprakriti Green Energies Pvt. Ltd., Kolkata on October 21, 2024
- ToT to M/s Vintara Elements Pvt. Ltd., Hyderabad on November 20, 2024
- ToT to M/s Rati Greetech Pvt. Ltd., Delhi on February 3, 2025
- ToT to M/s Licell Recycling LLP, Coimbatore on February 21, 2025
- ToT to M/s Swachha Urja Nirman LLP, Mumbai, on March 17, 2025

#### 9.3.3.2 The planar plasmonic sensing film technology developed by C-MET Thrissur is transferred to M/s Indriyam Biologics Pvt Ltd. Thiruvananthapuram on August 9, 2024.

#### 9.3.3.3 Following ToT's were transferred on 27.06.2025 during TecVerse, New Delhi

- Graphene supercapacitors- M/s. Matlabs Technologies, Thane, Technology Developed by CMET Trissur
- Nano silver screen printable ink for flexible electronic applications- M/s. Glutrack Pvt. Ltd, Powai, Mumbai, Technology Developed by CMET Pune

- Silver Screen printed RFID tags technology for NFC applications- M/s. Glutrack Pvt. Ltd, Powai, Mumbai, Technology Developed by CMET Pune
- ToT agreement for Li-ion battery Recycling Technology– M/s Bridge Green Upcycle Pvt. Ltd., Chennai, Technology developed by COE-E-waste, CMET Hyderabad
- ToT agreement for Li-ion battery Recycling Technology– Ecolith Tech Pvt. Ltd., Delhi, Technology developed by COE-E-waste, CMET Hyderabad
- ToT agreement for ‘Rare earth Fluoride (Nd/Pr) process technology for Permanent Magnet production’ – M/s. Sonal Magnetics, Ahmedabad, Technology developed by CMET Hyderabad

#### 9.3.3.4 MOU with C-MET Centres

- IIT Roorkee- C-MET Hyderabad for the R & D collaboration in the area of E-waste management.
- IIT Ropar- C-MET Hyderabad for R & D collaboration
- Jawaharlal Nehru for Aluminium Research- C-MET Hyderabad
- M/s Voltix Semicon Pvt. Ltd, Pune for Development of LTCC Packages-C-MET Pune

### 9.4 Education and Research Network (ERNET) India :

#### 9.4.1 VSAT Network

ERNET India operates a VSAT Network in C-band which provides reliable Internet and Intranet connectivity for educational and research institutions nationwide. The Master Earth Station (MES), situated in Bengaluru, serves as the Network Operations Centre (NOC). The network was allocated 103 MHz transponder bandwidth on the GSAT satellite which is reduced to 76.5 MHz w.e.f. 01.08.2025. The bandwidth is efficiently utilized to deliver high-capacity SCPC VSAT connectivity services to the Lakshadweep and Andaman & Nicobar Islands.

The following are the major projects under VSAT Network:

- **High Capacity SCPC VSAT links for National Knowledge Network (NKN)**

ERNET India has established two high-capacity SCPC VSAT links for NKN project of MeitY located at (i) NKN Kavaratti, the U. T. of Lakshadweep Islands, operational since 1<sup>st</sup> March 2017; and (ii) NKN Port Blair, the U. T. of Andaman & Nicobar Islands, operational since 9<sup>th</sup> January 2018. The VSAT link at Kavaratti was operating at a capacity of 50 MHz which is currently reduced to 24MHz w.e.f. 01.08.2025 after implementation of OFC in the Lakshadweep islands; while the link at Port Blair functions as a backup to terrestrial connectivity with a nominal bandwidth of 2.5 MHz. These links are utilized by NKN to provide reliable connectivity to knowledge and educational institutions within the respective regions.

- **High Capacity SCPC VSAT links for LITSS Lakshadweep**

ERNET India has established nine High Capacity SCPC VSAT links for Lakshadweep Information Technology Services Society (LITSS) in 09 Islands of Lakshadweep viz., Agatti, Amini, Andrott, Chetlat, Kadmat, Kalpeni, Kavaratti, Kiltan and Minicoy. Initially, the links were made functional w.e.f. 31.10.2019 with the satellite bandwidth of 25.5 MHz, which has been further enhanced from time to time as per the availability of satellite bandwidth. Currently, these 9 links are operating with total 50 MHz of satellite bandwidth.

- **Eduroam (education roaming) services -Global Wi-Fi Roaming Services**

Eduroam, an abbreviation for education roaming, is a secure, globally accessible Wi-Fi roaming service developed to meet the requirements of the research and education community. The service facilitates uninterrupted Internet

connectivity for students, researchers, and academic staff from participating institutions, both within their home campus and while visiting other member institutions internationally. At present, eduroam is operational in over 120 territories worldwide.

ERNET India has been designated as the National Roaming Operator for delivering eduroam services within India. The service has been successfully adopted by both Indian and international users affiliated with higher education and research institutions. Prominent institutions including Indian Institutes of Technology (IITs), Indian Institutes of Management (IIMs), National Institutes of Technology (NITs), Central and State Universities, as well as various other esteemed organizations, have significantly benefited from this service, thereby promoting academic collaboration, mobility, and knowledge sharing across institutional and geographical boundaries.

#### 9.4.2 Establishment of Intelligent Educational Infrastructure (Smart) in Eklavya Model Residential Schools (EMRSs)

The project entitled “**Establishment of Intelligent Educational Infrastructure (Smart) in Eklavya Model Residential Schools (EMRSs)**”, approved by Ministry of Electronics and Information Technology (MeitY) and jointly funded by MeitY and Ministry of Tribal Affairs (MoTA), is being implemented by ERNET India in a phased manner. The objective of the project is to set up the educational infrastructure in EMRSs by creating ecosystem using latest tools and technologies, which helps to improve the learning outcome and also to provide the Internet connectivity in EMRSs. There are total 290 EMR schools covered in the project. The target of setting up of Intelligent Educational Infrastructure along with Internet Leased Line (ILL) connectivity at 174 Nos. of EMRSs has been achieved under Phase-1 and Phase-2 and total 1392 smart classes have been setup under the Project. The implementation of setting up of smart classes with Internet connectivity in another 116 EMR schools under Phase-3 is in progress and expected to be completed by March, 2026.

#### 9.4.3 Web Hosting Services

ERNET India offers web hosting services to a wide range of academic and research institutions and organizations. To support this, ERNET India has established a robust cloud-based web hosting infrastructure, providing both dedicated and shared ICT resources. This infrastructure enables institutions and organizations to efficiently host their websites, ensuring reliable and secure access to their online platforms.

#### 9.4.4 International Co-operation

ERNET India is one of the primary members of Asia Pacific Advanced Network (APAN) association which has members from various countries including India, Australia, New Zealand, Japan, Singapore, Malaysia, South Korea & China. ERNET India has been associated with APAN activities since the year 1998. APAN provides a forum for user communities to come together with network engineers to help promote and exploit opportunities to enhance research and education in relevant disciplines, like Tele-health, Natural disaster mitigation, Research collaboration, Knowledge discovery, etc.

The Director General of ERNET India is an elected Director of APAN Board. APAN has agreed to feature APAN-IN (i.e. ERNET India) in their upcoming printed Pulse Magazine as an APAN Member, which will be distributed at APAN60 in Hong Kong and APAN61 in Bangladesh.

ERNET India is also a member of Asia Pacific Network Information Centre (APNIC) under ‘Large’ category. APNIC is a Regional Internet Registry (RIR) for the Asia Pacific region for providing Internet number resources to its members. It is one of the world’s five RIRs (Regional Internet Registry’s) and is part of the Number Resource Organization (NRO). APNIC manages Internet resources according to policies developed through an open process of consultation and consensus.

### 9.4.5 Domain Registration:

ERNET India has been an exclusive registrar for domain name registration under the .IN Registry for the education and research sector for over two decades. By allocating academic domain names and offering integrated digital services, ERNET India plays a vital role in strengthening the digital infrastructure of educational and research institutions in India. Its support not only ensures a secure and credible online presence but also empowers institutions to participate effectively in the evolving digital and academic ecosystem, in alignment with national priorities like Digital India and the National Education Policy. To date, ERNET India has provided several thousand domain names to educational and research institutions across the country, including premier organizations such as IITs, IIMs, NITs, AIIMS, IISc, CSIR and many others. ERNET India domain portal <https://www.registry.ernet.in> can be visited to obtain more information of the domain related services including the value added services and the respective tariff of the services offered by ERNET India.

During the financial year 2024-25, ERNET India registered/renewed approximately 6175 academics, educational, and research domains. Currently, there are more than 18700 active domains registered under the domain services of ERNET India.

ERNET India registers domain names under the following categories:

- **ac.in** – for academic institutions
- **edu.in** – for educational institutions
- **res.in** – for research institutions
- **school.in** – for school
- **alumni.in** - for websites related to alumni associations or networks

Under **Internationalized Domain Names (IDNs)**, ERNET India also registers domains under:

- विद्या भारत
- शिक्षा भारत
- शोध भारत

To ensure high-quality services for its domain users, ERNET India offers DNS Services along with a suite of Value-Added Services (VAS), including Website as a Service (WaaS) and Learning Management as a Service (LMaaS).

Under the Value-Added Services, any institute (domain user) can easily create its own customized website and LMS portal with just a few clicks and minimal technical expertise. These services are designed to enhance the institution's digital infrastructure and support effective educational delivery.

Some of the Govt. academic websites such as <https://itiindranagar.edu.in>, <https://ayakkadhss.edu.in> , <https://polytechnicjawad.ac.in> and few others were developed using ERNET India's WaaS services.

### 9.4.6 Quantum Key Distribution-based Ultra-Secure and Reliable Optical Networks using Shared Fiber Topology

ERNET India jointly with IIT Indore and NSUT Delhi is executing MeitY funded project on “Quantum Key Distribution-based Ultra-Secure and Reliable Optical Networks using Shared Fiber Topology”, from Aug 2023 to Dec 2025. The objective of the project is to analyze a physical layer model of a quantum channel integrated with the existing optical networks, demonstrate co-existence of quantum and classical data channels, investigate new disaster aware strategies for providing survivability against natural disasters in optical networks integrated with QKD, and strategies for optimal placement of trusted repeater nodes (TRNs) in a metro area network.

### 9.4.7 Advanced Optical Communication Testbed –QKD Network Security

ERNET India is a consortium member of the IIT Madras-led Advanced Optical Communication (AOC) Testbed Project, funded by the Department of Telecommunications (DoT) under the Telecom Technology Development Fund (TTDF) for the period October 2023 to October 2025.

Under Work Package 15 (WP15), ERNET focuses on QKD Network Security in collaboration with C-DOT and MAQAN partners. The work involves integrating an additional QKD node into the existing MAQAN testbed, emulating security attack scenarios such as Trojan Horse and Fiber Tampering, and developing SDN-enabled path control mechanisms for secure rerouting during link failures.

ERNET India has successfully deployed and tested a QKD link at the Southern Army Headquarters, with the trials conducted in three phases:

- i) ERNET India – SETS link (1 km),
- ii) Southern Army DB Area – DP Sainik Institute link (3.078 km), and
- iii) DB Area – Avadi Signal Duct link (36 km).

### 9.4.8 A Comprehensive IoT Security Ecosystem and Sandbox

ERNET India executing a MeitY funded project on “A Comprehensive IoT Security Ecosystem and Sandbox”, executed jointly with C-DAC, IIT Madras, IIT Bombay, IIIT Bangalore, SETS and Amrita Vishwa Vidyapeetham. The objective of the project is to develop an IoT Sandbox Environment for validating the functionality and security of IoT devices and networks. This initiative focuses on creating indigenous hardware and software tools, including libraries, scripts, and evaluation methodologies, to enable comprehensive assessment of IoT systems.

The final objective is to integrate these protocol-specific suites into the IoT Sandbox Facility, providing a unified platform for end-to-end IoT protocol validation and demonstration.

### 9.4.9 Supporting National Cyber Security Mission:

The objective under this project is procurement and deployment of Networking, Security & Computing Infrastructure to establish Data Centers (Primary Data Centre (DC)) and Disaster Recovery Data Centre (DR)) along with IT infrastructure at various remote locations across India. To ensure reliable and high availability networking, ERNET India is setting up a robust Wide Area Networking infrastructure through Managed MPLS bandwidth for its Primary Data Centre (DC) and Disaster Recovery Data Centre (DR) and remote locations across India. The project is facilitating various organizations and entities as well as major events in the country to mitigate cyber-attacks and cyber incidents on a near real time basis.

Following are the key achievements/highlights of the project:

- Designed and Implemented IT Infra for two DC/DR and various Remote Sites with Multiple OEMs (Network Devices, Security and other devices).
- Currently, operating around 300 MPLs Links connected to DC and DR.

## 9.5 National Informatics Centre (NIC)

### 9.5.1 About National Informatics Centre (<https://www.nic.in>)

NIC under the Ministry of Electronics and Information Technology (MeitY) is the technology partner of the Government of India. NIC was established in 1976 with the objective to provide technology-driven solutions to Central and State Governments.

**NIC MANDATE:**

- Technology partner of the Government
- Design and Develop IT Systems for the Government
- Provide ICT Infrastructure to the Government
- Explore & Advise on use of Emerging Technologies

NIC is associated with the government in different aspects of governance by establishing a nationwide state-of-the-art ICT infrastructure and services for Central Government, State Governments, UT Administrations, Districts, and other Government bodies. With over 49 years of experience, NIC offers a wide range of services which play a significant role in delivering citizen centric e-services.

**9.5.2 Network Services****9.5.2.1 NICNET**

NICNET is a nationwide, multi-gigabit communication network in India, run and managed by the National Informatics Centre (NIC). It connects all central government ministries and departments and has a presence in 775+ districts, towards enabling e-governance applications and improving efficiency and transparency in government services.

NIC Network (NICNET) backbone comprises multiple 10 Gbps links with sufficient redundancy through fiber media from BSNL, PowerTel and RailTel. NIC States are connected through multiples of 10 Gbps links and NIC District Centers are connected through 34 Mbps, 100 Mbps & 1 Gbps links with redundancy built at State and District links.

NICNET through its connectivity also provides Internet and also has direct peering with BSNL, PowerTel, RailTel, NIXI, Google, Meta (Facebook), and Amazon; and has Caching services of Google, Facebook, and Akamai, for providing low latency high throughput services to its user and it also saves the Internet Bandwidth and thus the cost.

**9.5.2.2 NKN**

NKN is an innovative, cutting-edge, robust, and secured network, which provides a centralized multi-gigabit high-speed digital connectivity backbone for research & educational institutions and Government Organisations spread across India.

**9.5.3 Data Centre & Cloud Services****9.5.3.1 Data Centre**

NIC has set up state-of-the-art National Data Centres at Delhi, Pune, Bhubaneswar, Hyderabad, and Guwahati to provide cloud services to various central and state Government Ministries, departments, PSU etc. at all levels. These Data Centres are involved in round-the-clock operations and management of systems with on-site skilled manpower. These Data Centres are designed to provide a full bouquet of hosting services which include physical to shared hosting, dedicated servers with managed hosting solutions, infrastructure services like collocation, storage, backup & network services, Disaster Recovery (DR) etc. Many missions critical applications/web sites of various State and Central Government departments are hosted at these Data Centres.

**9.5.3.2 Cloud Services**

National Informatics Centre (NIC) has been providing Data Centre/ Cloud services to the Government at Central and State level to ensure Government services internally and for citizens. Under NIC Cloud services, more than 30,784

virtual servers have been allocated for various e-Governance applications to more than 2136 Ministries/ users and over 5000 websites of the Government are being served through NIC cloud. For rapid deployment of new services and to strengthen the existing capacities and services, the cloud capacities of the national cloud has been enhanced by government funding as well as by public private partnership under the National Government Cloud (NGC) project.

### 9.5.3.3 Command and Control Centre

Command & Control Centre (CCC) has been operational at NIC HQ with the objective of providing a single window solution for monitoring, troubleshooting and technical support for applications hosted in NIC Data Centers across the country. CCC has been providing following services:

- i. CDN service
- ii. Resource Monitoring Service
- iii. Application Performance Monitoring (APM)
- iv. NIC Assurance (Load Testing as a Service)
- v. Troubleshooting & technical support

### 9.5.4 Cyber Security

Cyber Security incorporates the security standards and procedures followed to ensure protection of sensitive data, personal information, intellectual property etc. Multi layered access mechanisms are implemented on information systems for prevention from security breach and unauthorized access.

#### 9.5.4.1 Network Security

NIC is constantly engaged in ensuring Cyber Security of NICNET information infrastructure through assessment, planning, deployment, management and administration of state-of-the-art security appliances and solutions. The security span comprises National and State Data Centers, over 1000 LANs of Govt. offices and MPLS networks, more than 2 Lac endpoints and a series of networking devices deployed across the country. The 24x7 Security Monitoring Centre ensures real time monitoring, detection, prevention, analysis and reporting of Cyber threats and attacks.

#### 9.5.4.2 NIC-CERT

NIC-CERT has been set up with the objective of creating a comprehensive security and incident response framework that integrates world class security components and inbuilt threat intelligence for detection, prevention, and incident management. Using the tools, the team monitors and correlates events that would help in generating a canvas of the attack surface and identifying the vulnerabilities and possible exploits. Continuous analysis of logs and traffic patterns enables early detection and mitigation of critical vulnerabilities. It undertakes measures to issue periodic threat intelligence, Security Alerts/ Tips and advisories to safeguard NIC's assets against cyber threats.

#### 9.5.4.3 Application Security

Security Audit of hosted Web Applications / Websites is taken up as per the NIC Security Audit policy. The Security Audit activity comprises Source Code Analysis, Automated scanning, and Manual Audit process. Periodic Audits in the form of Post deployment vulnerability Testing (Penetration Testing) and Vulnerability Analysis, SSL compliance testing, Version Detection for the application hosting environment with infrastructure compliance checks are also undertaken. Capacity building programmes for NIC, Government officials in the Information Security domain are taken up on a regular basis.

#### 9.5.4.4 NIC VPN (Virtual Private Network)

NIC's VPN service is used by Government officials, Central and State Government departments, PSUs, and Autonomous bodies under Central and State Governments to

- a) access e-governance applications and
- b) update their web sites and remotely manage the servers hosted in NIC's Data Centers.

#### 9.5.5 Web, Messaging and Support Services

##### 9.5.5.1 Gov.in Domain Registration Service

National Informatics Centre (NIC) is the sole authority responsible for registering domain names under the Gov.in domain, ensuring that the allocation process complies with the guidelines set forth by the Ministry of Electronics and Information Technology (MeitY). Domain names are not limited to English; they can also be registered in various official regional languages, using Internationalized Domain Names (IDN), which promotes the development of fully localized websites—from the domain name to the site's content—in different languages. This is a key step toward enhancing accessibility and inclusivity for regional users.

Currently, there are 4,718 active third-level domains along with 206 IDN domains and 145,690 sub-domains (registered under 3rd level domains which are hosted in NIC).

##### 9.5.5.2 Email

E-mail serves as the backbone of all e-Governance initiatives in the country. The service was implemented by NIC and has been massively used by both Center and State Governments. The service provides 24x7x365 support to a user base of more than 33 lakh officials under Ministries/ Departments/ Statutory bodies/ Autonomous bodies of both Central and State/ UT Governments. The prominent features supported by the service are multi-lingual support, Internationalized Domain Name (IDN), Standardized Official Template, User Persona, Video Conferencing Integration, Undo Send, Briefcase etc. The security features offered in the service are Multifactor Authentication, Geo-fencing, Device Mapping, Mail encryption etc.

To modernize legacy systems and enhance security, NIC selected a Master System Integrator model through a transparent GeM-CPPP process. The email migration began on 4th June 2024 in phases to ensure continuity. Key security measures included data encryption, multi-factor authentication, geo-fencing, IP restrictions, and real-time replication between data centers within India. SMS alerts for calendars and critical notifications were retained. Security audits by STQC (6th May 2024) and C-DAC (22nd August 2025) validated compliance and strengthened assurance.

Approximately 15.06 lakh official email accounts have been migrated to the new Zoho-based platform.

##### 9.5.5.3 Messaging services (SMS, WhatsApp, IVR)

**SMS:** The NIC messaging ecosystem continues to support SMS notifications, delivering approximately 15 crore messages daily to over 300+ departments, ensuring timely alerts for calendar events, workflow triggers, and critical system notifications.

**WhatsApp:** The NIC WhatsApp messaging ecosystem continues to deliver real-time notifications, with 25 projects integrated into the service.

#### 9.5.5.4 Parichay Single Sign-On (SSO)

**Parichay (SSO)** is a multi-lingual single sign-on platform designed to integrate Government applications under a single authentication framework. It provides a centralized session and user authentication service in which one set of login credentials can be used to access multiple Government applications. Once the user logs into Parichay, all the services that the user is authorized to access should comply with Parichay's guidelines. This platform enhances the security posture of all Government applications as it provides a secure sessions-based access and provides two factor authentications with geofencing.

#### 9.5.5.5 Jan Parichay Meri Pehchaan – National Single Sign-On

Jan Parichay authenticates the user and does authorization based on the rights given to the user, thereby, eliminating further authentication/authorization prompts when the user switches services during the same session.

To provide multiple advantages to the Government and citizens, it was proposed to leverage the 3 prime SSO Solutions: Jan Parichay, ePramaan, and DigiLocker under MeitY and offer them as a single unified offering, Meri Pehchaan, to the citizens.

This resulted in a scalable and redundant framework offered by the Government to the citizens with a standardized user interface across all the 3 SSO's thereby enabling a national SSO platform.

#### 9.5.5.6 Government Instant Messaging System (GIMS) - Sandes

SANDES stands as a secure and indigenous open-source instant messaging platform developed by the National Informatics Centre (NIC). It is designed to facilitate communication between government entities (G2G) and between the government and citizens (G2C) with a strong focus on security and privacy. Every message within Sandes is encrypted end-to-end (E2EE) for enhanced protection. The key features of Sandes encompass one-on-one and group chat functionality, audio and video calls for both individual and group conversations, seamless contact synchronization with your phone's address book, the ability to share media files and message broadcasting. The Sandes adheres to the Social Media Intermediary Guidelines and the government's Privacy and Data Retention policy, ensuring compliance with official regulations.

This versatile platform is actively used by various government ministries and state departments. The Sandes App is readily available on both the Play Store and the App Store, making it easily accessible to authorized users.

#### 9.5.5.7 Service Desk

NIC Service Desks (NSD) has been steadfast in its mission to provide a single-window platform for resolving issues related to a wide range of services offered by NIC. NSD serves as the Single Point of Contact (SPOC) for government entities, statutory bodies, and the general public, enabling them to raise queries, calls, complaints, and suggestions for any issues they encounter in their day-to-day activities with different NIC services.

NSD enables support through a toll-free call centre (1800-111-555) and a user-friendly web portal (<https://servicedesk.nic.in>), where complaints related to any NIC services can be effortlessly lodged.

### 9.5.6 Video Conferencing Technologies and Services

#### 9.5.6.1 Video Conferencing Services

NIC provides one of the largest High-Definition Video Conferencing Services in the country for the Central and State Governments Departments.

NIC-VC Services seamlessly integrates laptops, desktops, tablets, smart phones, room-based systems, and legacy equipment in order to provide 'Any time Anywhere' Service.

NIC has also developed an in-house webinar application by integrating with BharatVC and webcast streaming application. This is being used to organize training programs, workshops, seminars, and other official events.

NIC's video-conferencing services are being extensively used by highest dignitary of the country i.e., Hon'ble President of India, Hon'ble Vice President of India, Hon'ble Prime Minister of India, Union Ministers, Governors, and Chief Ministers of States, Cabinet Secretary, Chief Secretaries, Chief Election Commissioner, Chief Information Commissioner, and various other senior officials across the country.

#### 9.5.6.2 Webcast & Webinar Services

At NIC, the events get an optimum webcast with flawless production quality. NIC's webcast service offers various solutions for an event, bringing onsite production, hosting, and streaming to millions of online viewers.

NIC has been providing live/on-demand webcast services to Central and State Government for important National, International, and regional, educational events, conferences, and other live events. Live webcast services are provided for Government TV channels such as Lok Sabha TV, Rajya Sabha TV, Doordarshan News, UGC – CEC higher educational channel among others on a 24x7 basis.

#### 9.5.7 Geospatial Technology and Services

- **BHARAT MAPS (<https://bharatmaps.gov.in/>, <https://stategisportal.gov.in/>):**

To fulfil the objectives of Digital India and to establish end to end geospatial electronic delivery systems as part of National GIS Mission Mode Project, GIS Platform was established by NIC using NICMAPS Services. It has been revamped as "BHARAT MAPS." This depicts core foundation data as "NICMAPS," an integrated multi-scale, multi-resolution base map service using reference data from Survey of India, ISRO, FSI, RGI and so on. This encompasses a large number of layers containing administrative boundaries, transport layers such as roads & railways, forest layer, settlement locations etc., Service offerings include India specific Basemap services, updated Admin boundary database, coding and reverse geocoding services and All-India rural focused navigation services.

STATE GIS PORTAL empowered by BharatMaps is a simplified user interface for all the states and union territories of India. Six Centers of Excellence in GIS have been established in Madhya Pradesh, Tamil Nadu, Odisha, Bihar, Andhra Pradesh, and Assam. They are also offering GIS services to various departments.

- **Map Service Portal (<https://mapservice.gov.in/>):**

Map Services are being provided to various ministries and departments through the map services platform. About 250 applications are using these services.

- **ONE MAP GIS PORTALS (<https://umd.nic.in/gnida>, <https://onemap.nic.in/punjab>):**

OneMap GIS portal provides a centralized, GIS-based solution that integrates drone imagery, layouts, master plans, and MIS data into a single platform, enabling accurate planning, efficient monitoring, and citizen-friendly services.

- **Survey of Villages Abadi and Mapping with Improvised Technology in Village Areas (SVAMITVA) (<https://svamitva.nic.in/>, <https://grammanchitra.gov.in/>):**

SVAMITVA Dashboard Application provides role-based access to update status on Key Performance Indicators of SVAMITVA scheme dealing with drone surveys of village Aabadi areas and activities involved there resulting

in Property card generation and distribution. The key stakeholders are the Ministry of Panchayati Raj, Survey of India, State Govts and NIC. The Portal was also used to distribute property cards to beneficiaries through SMS. The drone data which is generated under SVAMITVA project being integrated with GramManchitra application for rural planning.

- **Parivesh GIS Portal (<https://parivesh.nic.in/>):**

In PARIVESH application for the Ministry of Environment, Forest and Climate Change GIS based decision support is integrated in the workflow of Clearance process from Stakeholder level to decision authority level.

- **Power Portal (<https://indiapowermap.gov.in/>):**

India power portal is a GIS based web application for mapping and analysis of electricity infrastructure. This project aims at mapping the existing assets and planning for new assets under various schemes in REC and IPDS under the ministry of power for strategic decisions.

- **GIS For Financial Inclusion (<https://bankgis.nic.in/>):**

DBT-GIS is an application of mapping of financial infrastructure across the country to facilitate financial inclusion of rural masses so that Direct Benefit Transfer can reach the unreached.

### 9.5.8 ICT Solutions for Northeastern Region

Project Monitoring System (PMS) for monitoring progress of projects under various schemes has been implemented by the Ministry of Development of Northeastern Region (MDoNER) .

#### A. POORVOTTAR SAMPARK SETU & 10% GBS MIS (<https://nesetu.mdoner.gov.in/>)

Hon'ble MoS, MDoNER, launched the 'POORVOTTAR SAMPARK SETU', a powerful portal to manage Minister's visits to NER in a more effective, transparent, and impactful manner. The portal provides valuable insights and graphical information about State wise/ District wise visits to NER. Another module in this portal facilitates monitoring of the financial expenditure made by 54 non-exempted ministries under 10% GBS.

#### B. DoNER Analytics Dashboard (<https://dashboard.mdoner.gov.in/>)

This Portal helps the decision makers to monitor the physical and financial progress of various projects under the GOI Schemes in North Eastern states. Portal showcases 836 KPIs of 144 GOI schemes from 52 GOI Ministry /Department covering 6 major sectors.

#### C. POORVOTTAR VIKAS SETU – Pre-Sanction (<https://nesetu.mdoner.gov.in/vikassetu/>)

This Portal is a tool for managing complete project life cycle broadly classified under pre-sanction and post-sanction. Portal assists in monitoring the implementation of the Projects pertaining to the North Eastern Region commencing from the submission of the Project Proposal in the form of Concept Note & DPR until the completion of the Project.

#### D. POORVOTTAR VIKAS SETU – Post Sanction (<https://ne.pmgatishakti.gov.in/DoNER/login>)

PM Gati Shakti portal in addition to GIS mapping of the projects has been customized to act as a Project Monitoring System (PMS) for all the MDoNER projects. In this portal around 3548 projects of various schemes of MDoNER are present and monitoring the implementation and progress of projects & updation of data related to all those projects is carried out.

#### E. Projects Dashboard (<https://nesetu.mdoner.gov.in/projects/>)

This is the Projects Dashboard, which shows the details related to all the projects implemented by MDoNER and NEC.

### 9.5.9 Innovation and IPR

With respect to Intellectual Property NIC's IPR Profile is as follows:

- Total Copyrights Registered - 97.
- In 2025 Registered – 2, Applications pending at Copyright Office – 1
- Total Trademarks Registered - 1 Trademark in the USA; Trademark of 10 NIC Logos; Trademark of NIC Application Logos Applied for - 7

Total Patents Granted - 1 Patent in the USA; In 2022; 1 Patent for Jal Tarangini applied by NIC Assam in 2024.

### 9.5.10 eGovernance Services and Products

NIC is playing an instrumental role in executing key IT projects, in close collaboration with Central and State Governments, making the last-mile delivery of government services to the citizens a reality, through a variety of digital solutions.

#### 9.5.10.1 eOffice

The eOffice project, a flagship IT initiative of the National Informatics Centre (NIC), serves as a complete digital workplace solution aimed at fundamentally transforming government operations. By replacing traditional, paper-based workflows with electronic administration—and strictly adhering to the Central Secretariat Manual of Office Procedure (CSMOP), formulated by Department of Administrative Reforms and Public Grievances (DAR&PG)—the system dramatically improves internal efficiencies, leading to quicker, more informed decision-making and enhanced public service delivery.

- a. The comprehensively revamped eOffice Analytics Dashboard was successfully launched in April 2025, with enhanced data visualization and advanced metrics.
- b. The Chief of Army Staff honoured the DG NIC in recognition of eOffice's successful implementation within the Indian Army.
- c. In March 2025, the Bhashini translation utility was successfully integrated with eOffice.
- d. The eOffice Mobile Application was officially launched in August 2025, providing users with anytime, anywhere accessibility to files and workflows.

#### 9.5.10.2 My Gov : A platform for citizens' Engagement towards Good Governance (<https://www.mygov.in/>)

The MyGov platform has successfully empowered citizens by providing them with a direct voice in the governance process. It has established a framework that enables citizens to participate as stakeholders actively, not only in policy formulation but also in implementation through actionable tasks and meaningful discussions.

#### 9.5.10.3 India Portal

The India Portal started in 2005 as a mission mode project under the National e-Governance Plan to serve as a single window for government information and services, promote standards for e-governance, and encourage innovative digital initiatives. Initiatives/activities under the aegis of India Portal are:

- National Portal of India
- National Government Services Portal (NGSP)
- Integrated Government Online Directory (iGOD)
- Guidelines for Indian Government Websites (GIGW)
- Know India Portal

#### 9.5.10.4 S3WaaS

S3WaaS (Secure, Scalable and Sugamya Website as a Service) developed by the National Informatics Centre (NIC) helps government entities to generate Secure, Scalable, and Sugamya (Accessible) websites. It simplifies website development by offering government entities multiple website templates with customization features and an easy content management system, enabling them to maintain their online presence with minimal effort and technical expertise.

S3WaaS offers WCAG 2.1 and GIGW 3.0 compliant, accessible, and responsive designs; secure hosting on the robust NIC Cloud infrastructure; centrally managed monitoring and maintenance; automated technical updates; a robust disaster recovery mechanism; and pre- and post-migration support. These features ensure swift deployment and continuous compliance with guidelines issued by the Government of India.

S3WaaS supports multilingual content publishing in 18 official Indian languages and integrates seamlessly with social media platforms to cater to the needs of a diverse audience.

#### 9.5.10.5 Open Government Data-OGD 2.0 /Bharat Data Platform (BDP)

OGD 2.0 platform provides Government to Government (G2G) service by allowing Ministries/Departments/ States/Organizations to publish and manage their datasets on the Platform through a Chief Data Officer (CDO). The datasets are available to all free of cost.

The datasets are updated with their respective granularity. Some of these datasets are updated multiple times a day in real time e.g., Real time Air Quality Index (AQI), eShram, PINCODE, Rainfall, Aadhaar Enrolment and Update, Patent, Kisan Call Center, Current Daily Price of Various Commodities from Various Markets (Mandi), etc. .

Many States had adopted the NDSAP policy for States Data Sharing on OGD platform. Replica of the OGD platform as a SaaS (Software as a Service) model has been made for these States.

#### 9.5.10.6 Electronic transaction Aggregation and Analysis layer (eTaal)

eTaal 3.0 aims to measure qualitative aspects of eService delivery, enabling performance comparisons across Central Ministries, States, Union Territories, and Smart Cities, down to the district level. It also incorporates AI-enabled chatbots, predictive analysis, and Business Intelligence (BI) dashboards for generating meaningful insights.

#### 9.5.10.7 Gov.in Secure Intranet Portal

The Gov.in Secure Intranet is a Government-to-Employee (G2E) initiative designed to significantly enhance the operational efficiency of Government officials across Ministries and Departments. It offers seamless access to multiple government applications through a robust Single Sign-On (SSO) mechanism, eliminating the need for multiple separate logins. This integrated platform facilitates key workflows including calendar scheduling, task and appointment management, and real-time monitoring of ongoing tasks assigned to individuals or teams. Comprehensive reports and dashboards provide enhanced oversight and support data-driven decision-making.

#### 9.5.10.8 CollabFiles

CollabFiles is an indigenous platform designed to Connect, Create, Share, and Collaborate on office documents. It is envisioned as a secure, scalable, web-based, cloud-enabled, and mobile-responsive solution that enables users to create and manage documents, spreadsheets, and presentations collaboratively. The platform provides strategic control and data security, empowering Government users to work seamlessly on CollabFiles via both web and mobile interfaces. Access is facilitated through Parichay and JanParichay, the Government's Single Sign-On (SSO) frameworks, ensuring secured and privileged authentication across all services.

### 9.5.10.9 Direct Benefit Transfer (DBT) 2.0

DBT Bharat Portal has been designed with the intention of monitoring the enhancement in the delivery of public schemes and services in India by ensuring that the intended beneficiary receives the in-kind and monetary benefits of government services and programs on time and efficiently.

### 9.5.10.10 ViAS (erstwhile TejasVI ) Visualisation & Analytics Services Tool

<https://vias.nic.in/demo> (For training and demonstration)

Visualisation & Analytics services (ViAS) developed in-house by NIC, is a powerful & versatile tool for providing end-to-end data visualisation & analytics services on aggregated data which facilitates data collection, transformation, visualisation and dashboarding. It integrates with other NIC products, data-driven conditional alerts, and multilingual support, making it a vital tool for fostering data-driven governance. For production use, ViAS tool needs to be deployed on-premises by the user organisation at their end.

### 9.5.10.11 eSamikSha

eSamikSha portal facilitates PMO and Cabinet Secretariat to keep a track on all the pending work in various departments and direct the concerned authorities to take proactive steps by fastening the pace of projects as per expectation. The portal helps to bring transparency and enhance the interoperability between Government-to-Government (G2G) and Government to Businesses (G2B).

One separate instance of eSamikSha has been implemented for Rashtrapati Bhawan (RB-eSamikSha).

### 9.5.10.12 Digidhan Dashboard for monitoring Digital Payment Transactions

The Digidhan Dashboard serves as a comprehensive platform for monitoring digital payment transactions across the country. It provides detailed statistics on the number and value of transactions, categorized by various types such as UPI, debit cards, credit cards, and more. Additionally, the dashboard offers insights into the platforms facilitating these transactions, including BHIM, UPI, and a range of e-wallet services.

The platform supports the monitoring of digital payments across 16 distinct payment modes, such as UPI, USSD, IMPS, and debit cards, utilizing data from sources like the Reserve Bank of India (RBI), National Payments Corporation of India (NPCI), and over 118 public and private sector banks.

### 9.5.10.13 Dashboard for Analytical Review of Projects Across Nation (DARPAN)

NexGen DARPAN © (Dashboard for Analytical Review of Projects Across the Nation) is a multilingual, configurable SAAS product revolutionizing governance through real-time data integration from 1,213 flagship projects comprising 8,273 KPIs through secure web API.

DARPAN renders a comprehensive suite of analytics i.e., Descriptive Analytics, Trend Analytics, Demographic Analytics, Peer Comparison Analytics. Dashboard generates monthly Data Quality Index (DQI) and Star Rating mechanism, dynamic formula-based Ranking and Grading (Project/Department/District & Composite), Score Card, Leading (Top 5) and Laggards (Bottom 5) districts to promote healthy competition among departments and districts.

### 9.5.10.14 PRAYAS – Pursuing Excellence in Governance

PRAYAS – “Dashboard of Dashboards” is an initiative developed under the guidance of the Prime Minister’s Office (PMO) through a collaborative effort by the Data Analytics Informatics Division (DAID), NIC, and the Centre of Excellence for Data Analytics (CEDA), NICSII.

PRAYAS enables interactive visualizations and actionable insights through identified Key Performance Indicators (KPIs) to monitor the progress of Government of India schemes and its effective implementation. The platform offers a unified view of schemes across multiple Ministries and Departments through a single, integrated interface. It ensures transparency by integrating respective MIS and IT systems of Ministries and Departments through secure APIs.

To further enhance user experience, PRAYAS is enabled with features like Chatbot and Data Monitoring Dashboard.

#### 9.5.10.15 Rashtriya Puraskar Portal

The Rashtriya Puraskar Portal is a unified national platform that streamlines the end-to-end nomination and evaluation process for all National Awards, ensuring transparency, accessibility, and efficiency while eliminating manual workflows. Developed by NIC as a secure and scalable digital solution, the system supports multi-factor authentication, provides comprehensive dashboards for Ministries and Departments, and is continuously enhanced for performance and audit compliance. The portal has significantly expanded citizen participation, enabling nominations from remote and underserved regions and bringing grassroots achievers into national recognition frameworks.

#### 9.5.10.16 Government eProcurement system of NIC (GePNIC©)

GePNIC provides a platform to conduct online tendering for Goods/ Works/ Services including Global Tenders, ADB/ World Bank/MDB Tenders, Turnkey projects, Rate Contracts, and tender cum auction. Widely used in 31 States / UTs and over 800 Central Govt entities. Software as a Service model (SaaS) enables quick onboarding, User entity specific rule configuration, regular capacity building, and handholding support as part of the implementation. Central Public Procurement Portal (eprocure.gov.in) has been integrated with Government eMarketplace [GeM-CPPP] as per directions of Procurement Policy Division, Min of Finance. The platform offers advanced features such as Negotiations, Tie Breaker mechanism, Fixed Rate Contracts along with eAgreement-based contract finalization and secured Electronic Bank Guarantees (eBG). Since inception, 157.28 lakh tenders have been processed on the platform, with a cumulative value of ₹227.79 lakh crore.

#### 9.5.10.17 e-Granthalaya

e-Granthalaya is a Digital Solution for Automation & Management of Government Libraries developed and maintained by National Informatics Centre. The Software is multi-lingual, UNICODE compliant, provides an online data entry solution and compliance with library standards. It provides a complete cloud ready solution to convert traditional libraries into Digital Library. The digital solution is compliant with international standards prevalent in libraries with the use of the latest ICT technology.

It is implemented for 5095 libraries in (SAS model) and 3000 libraries have deployed in their premises as a product, with over 34 lakh members.

#### 9.5.10.18 Digital Archiving and Management

National Informatics Centre (NIC) is leading the charge in promoting the need for digitizing and archiving government documents. Using DSpace, an open-source software tool for managing digital assets, NIC is helping government departments build robust digital repositories. DSpace enables the seamless creation of digital archives where all types of content such as text, images, etc. can be securely stored and easily accessed.

#### 9.5.10.19 Swagatam

Swagatam is an initiative of the Government of India, developed by the National Informatics Centre (NIC), to simplify and digitize the visitor appointment process in government offices. It is a cloud-based, centralized visitor management system with secure and user-friendly features. Citizens can register on swagatam.gov.in, request appointments,

receive SMS/email confirmations, and generate digital gate passes. It also supports Temporary Passes for non-official employees or visitors. Swagatam is implemented in over 600 locations across Ministries, Departments, and Government offices nationwide.

### 9.5.10.20 NAPIX

The NIC API Exchange (NAPIX), serves as a unified API marketplace and gateway tightly coupled with API Setu, enabling secure, seamless, and scalable data exchange across government departments, enterprises, and citizens. By providing real-time, standards-based interoperability, NAPIX eliminates duplication in API development and integration, ensuring efficient and consistent digital service delivery.

Since its launch under the National Data Highway initiative of MeitY, NAPIX has transformed government system interactions by streamlining API lifecycle management, simplifying complex integrations, and ensuring interoperability across domains.

NAPIX functions as a central hub for mission-critical data exchange for internal and intra government APIs, supporting key applications including eCourts, Interoperable Criminal Justice System (ICJS), Reproductive and Child Health (RCH), eOffice, Local Government Directory, Jeevan Pramaan, Parivahan, and more.

### 9.5.11 Mobile Apps Store

Mobile Application Division has Nodal center in NIC-HQ Delhi and four competency centers at Chennai, Shimla, Patna, and Kannur. All the centers are collectively working for development and hosting of mobile apps in Android and iOS. To bring all these apps under one umbrella and ensure better visibility and global reach through a single point of contact, NIC has subscribed to user accounts on the Google Play Store and Apple App Store. As a result, a total of 326 mobile apps have been published on the Google Play Store, and 129 mobile apps are available on the Apple iOS platform.

### 9.5.12 Centre of Excellence and Software Development Unit

#### I. Centre of Excellence for Data Analytics (CEDA)

**PRAYAS PM Dashboard:** Dashboard of Dashboards developed for the PMO, Provides analytical insights for Flagship Programs & Schemes of the Government.; 186 Schemes, 1244 KPIs across 61 Min/Depts already on-boarded, data updation through API

#### Data Analytics Solutions

Developed for more about 12 Ministries/Departments- eWay BILL-GSTN, Import/Export-D/o Commerce, Immigration Analytics-Bureau of Immigration, RD Schemes-D/o RD, Tribal Scholarships-M/o Tribal Affairs, Steel Analytics-M/o Steel, Ministry, D/o Commerce-Trade Analytics, Public Distribution System (PoC), National Scholarship Portal (PoC), Ministry of Consumer Affairs (Poc), VBSY scheme survey dashboards (Poc) etc.

**Pragyan Platform:** Enterprise-ready Data Integration, Exploration & Visualization Platform; To build analytical dashboard and required visualizations as per your own data sources

#### II. Centre of Excellence in Artificial Intelligence (COE-AI)

**A. NIC AI Services :** NIC has Created Artificial Intelligence Resource Division, which has been working towards increasing use of Artificial Intelligence Technologies in eGovernance space, helping Mission Mode Projects, Central & State Govt. Departments & Organizations with providing various AI services facilitated through Meghraj Cloud of NIC such as :

**Image & Video Analytics Assistance by NIC (IVAANI):** is a bouquet of AI services based on Computer Vision with following Service listings.

- **AI Satyapikaanan** - AI Face Verification & Person Identification Services. It is available through API Services over the NAPIX gateway. It can be considered as a Digital Public Infrastructure as it is being used for a wide range of applications by different ministries/departments/ states etc.. RTO uses it for Face Verification for Online Learners' License Exam, Automatic Driving License renewal, Photo Image Analytics for Online Form submission by NTA for JEE, NEET, CTET etc., UPSC, For Geo Fenced Mobile based attendance of skill Development trainees at private training centres by Govt. of West Bengal, for Life Certificate for Pensioners by Meghalaya, for e-visitors management by Raj Bhawan Uttarakhand, for Suspect Identification through face recognition in ICJS portal etc. AI Satyapikaanan is a Copyrighted Product Service of NIC.
- **AI Abhigyan** – AI powered identity recognition and information extraction system designed for documents like Aadhaar, PAN, EPIC, Passport etc. It helps extract keys like Name, DoB, Gender, Photo, ID Card No. etc. facilitating to match these details with form fields ensuring secure and efficient digital workflows. The service is available over NAPIX, API gateway of NIC.
- **AI Parkhi** - AI Document Image Analytics Services for legibility checking of documents uploaded. It has been facilitated to check Engineering drawings clarity for Online paperless Licensing for PESO & PoC ongoing for legibility checking of uploaded Documents for Supreme Court of India.
- **AI Vihangam Drishti** - GeoSpatial Image Analytics Services for classifying aerial images and facilitating planning and disaster management. Helped in the estimating area with Concrete rooftop in Villages for solar panelling.

**Text Analytics Assistance by NIC (TAANI):** with following Service listings & AI pipelines with combinations of them facilitated for various projects.

- **AI Matra** - Text Transliteration is provided as a Service' in 22 Indic Languages. Any user can avail this service by onboarding through Meghraj Cloud Service of NIC. This is a service for transliteration of text from any of the mentioned scheduled Indic languages to English and vice versa. It also helps users edit the content in that language using an English keyboard. It is being extensively used for printing Sickle cell Anaemia cards. NIC has also developed two AI models for multilingual Script Recognition in mixed mode texts that include both Native and Romanized scripts, in collaboration with IIT Roorkee and published a paper in IEEE.
- **AI Panini** - Text Translation Services facilitated in 22 Official Indic Regional Languages. An Instance of AI Panini has been created with a legal corpus from English to Hindi and is being extensively used by the Supreme Court of India.
- **AI Saransh** - Text Summarization Services in English which can be used for Extractive Text Summarization in English. It summarizes the content of the text document by extracting exact lines from the content that the model considers as important to making the summary. Alternately Generative AI based abstractive summary is also facilitated.
- **AI Shruti** - Streaming Text Transcription Services in 10 Indic Languages Bengali, English, Gujarati, Hindi, Malayalam, Marathi, Odiya, Tamil, Telegu and Kannada available over NICNET.
- **AI Nibhrit** - AI based solution to mask Personal Identifiable Information (PII) like Fingerprints, Aadhaar Numbers and PAN on PDF documents has been developed that takes pdf document as input and returns:
  - Co-ordinate of the regions in pages to be masked
  - It can also return a masked pdf document, if necessary.

The PAN and Aadhaar numbers are masked from the text available in the PDF and from the PAN and Aadhaar card images in the PDF as well. The service is available over NICNET.

AI Nibhrit also facilitates extraction of Highlighted points in a pdf including handwritten notes. It then facilitates Coordinates of the regions in the pages so highlighted/ scribbled for further use.

AI Nibhrit is a Copyrighted Product Service of NIC and is implemented in Directorate of Stamps and Revenue in many states and by RERA in Himachal.

**Virtual Assistance by NIC (VANI):** is a conversational AI framework with following Components Multilingual Chatbot Services - A paid Service under NICSF facilitated with VANI Framework with intent design and in-house Conversational AI engine. VANI facilitates Multilingual chatbots through integration with AI Panini for 22 Indic languages text translation & with AI Shruti to facilitate voice to text in 10 Indic languages VANI framework is copyrighted by NIC.

**Generative AI Services (AI Anveshika) :** GenAI Services have been facilitated on prem using LLM & RAG pipelines for a few departments and organizations. It helps to answer online queries on content already ingested and also facilitates template based brief generation from uploaded documents.

**B. Expansion of AI Supercomputing Infrastructure at NDC Shastri Park:** NIC is in the process of making an additional 64 AI Petaflops compute operational in FY 2025-26. This will take the super compute availability in Meghraj Cloud of NIC to 126 AI PetaFlops.

**3. The Centre of Excellence in Blockchain Technology (CoE-BCT)** has been established at NIC, Karnataka with a vision to build niche applications using Blockchain technologies in close coordination with the Government, which can be rolled out across the country. Blockchain networks have been established with Blockchain nodes distributed across NIC data centers.

National Blockchain Framework (NBF) is an initiative of MeitY to facilitate large scale adoption of Blockchain technology in the domain of e-Governance As a part of this initiative, NIC has deployed State-of-the-art distributed infrastructure at Data Centres located at Pune, Bhubaneswar, Hyderabad, and setup up Blockchain Frameworks for high availability. The CoE has also developed and deployed platforms for easy integration with eGovernance applications.

The CoE is instrumental in the design and deployment of various Blockchain platforms such as Certificate Chain, Drug Logistics Chain, Property chain, Document chain, and Judiciary chain. These generic platforms can facilitate easy pan-India roll-out for any Ministry / Department.

About 15 State / Central Government departments are actively using the solutions. 10Cr Documents are available in the blockchain. 34 Cr verifications of property data have been done in the last 3 years.

**4. Centre of Excellence (CoE) in Application Security** has now been renamed as Regional Application Security Audit Division and was established to provide state-of-the-art Security solutions & services for the Information Technology needs of the Government of India, and establishing best practices, standards, and initiatives in Application security. The divisions are located at Bhubaneshwar, Guwahati, Jaipur, Lucknow, and Thiruvananthapuram.

**5. NIC Software Development Units (SDU)** provide state-of-the-art services using the latest tools and technology. NIC Software Development and Training Centers are engaged in important e-Governance projects in respect of development of software on turnkey basis, implementation, project level training, and subsequent support.

**6. Open Technology Group (OTG)** focus areas are to evaluate and recommend Open-Source Software (OSS) for e-Governance Solutions, maintain distribution repository of recommended OSS for usage across NIC, guide, and handhold NIC teams in keeping their OSS driven system Secure and provide training on OSS. Also, provision of support services for adopting OSS in various e-Governance Projects and applications under MeitY.

OTG continued to modernize and secure the open-source infrastructure supporting over **12,000 cloud VMs** across multiple platforms for all the data centers across the country.

**Key operational activities include:**

- Infrastructure Modernization & Security
- Custom Solutions for National Projects
- Innovation & Automation

7. **NIC Centre of Excellence on Microservices (CEM)** serves as a resource centre for consultancy in identifying, developing, and migrating feasible monolithic applications to microservices-based architecture.

### 9.5.13 NICS

National Informatics Centre Services Incorporated (NICS) is a Government of India enterprise under National Informatics Centre (NIC), Ministry of Electronics & Information Technology (MeitY). It was established in 1995 as section-25 Company (now section 8) with NIC, MeitY as sole promoter. NICS has expertise in ICT project execution and has executed over 28,000 ICT projects for Ministries /State Governments / PSUs. All key officials in NICS including Managing Director are provided by NIC through deputation. NICS has empanelled organizations based on their expertise in various areas of information technology through an open tender process through which the procurement by the User Department is fast-tracked. NICS had reached an impressive 32% jump in its revenues in FY 2024-25 and a turnover of ₹3,110 crores.

### 9.5.14 NIC Training Unit (NICTU) at the Lal Bahadur Shastri National Academy of Administration (LBSNAA), Mussoorie [www.lbsnaa.gov.in](http://www.lbsnaa.gov.in)

#### NICTU supports LBSNAA through

- “End-to-end Training and Capacity Building of Civil Servants in Digital skills” including applications of digital technologies for governance and administration,
- Development of digital systems, dashboards, eGov apps, hardware, cloud, GIS, networks, ICT human resources, cybersecurity towards “Enhancing Digital Infrastructure at LBSNAA”,
- “Outreach and collaboration” - Demonstration/ replication of “NICTU’s Technology solutions” and coordination with external experts for “Techno-Managerial Solutions”.

### 9.5.15 Capacity Building

- **VidyaKosh – A Learning Management System (LMS):** VidyaKosh, the e-Learning initiative of NIC, provides the facility of anywhere and anytime learning experience to the learner by providing a rich set of professionally tutored courses through efficient administration of self-learning, for all the technical officers in NIC.
- **iGOT:** Training Division has successfully on boarded all NIC officials on the iGOT Karmayogi platform. Six courses have been identified for each designated group of officials, and Assessment-based Training Plans have been created.
- **Rashtriya Karmayogi Large Scale Seva Bhaav Initiative:** The Rashtriya Karmayogi Large-Scale Jan Seva (RKLSJS) initiative is part of the Government’s broader mission under Mission Karmayogi, which focuses on strengthening officer capacity for citizen-centric governance, service delivery, and digital public systems.
- **Webinar:** NIC’s Webinar platform aims at sharing knowledge among peers and updating officers on emerging technologies, enabling sharing various technical experiences & challenges faced in work and improving communication skills.

- **Classroom based Training Programs (MDP):** Various need-based training programs were organized for NIC officers across NIC HQ, State and District Centres, and select institutions. Additionally, NIC collaborated with premier institutions including IIMs, IITs, etc. to leverage their faculty and infrastructure.
- **Classroom/online Training (TDP):** NIC has been conducting multiple numbers of residential training programs and workshops on various emerging technologies.

### 9.5.16 International Cooperation

The International Cooperation Division of the National Informatics Centre (NIC), Ministry of Electronics & Information Technology, is dedicated to fostering global collaboration in digital governance and ICT innovation. It serves as the institutional interface for engaging with international delegations, facilitating knowledge exchange, technical discussions, and partnership-building activities that advance the deployment and customization of Indian e-governance solutions globally.

- Organized and hosted multiple high-level meetings and virtual sessions with global partners (such as Cuba, Mauritius, and Lao PDR) to explore technical cooperation in government e-services.
- Presented detailed demonstrations of flagship platforms like eHospital to international delegates, explaining architecture, customization, and data migration methodologies.
- Led in-depth discussions focusing on localization, compliance needs, and partner-specific challenges, enabling collaborative evaluation and adaptation pathways.

### 9.5.17 Media & Outreach

NIC's official website (<https://www.nic.gov.in>) and a strong presence across social media platforms - X (Twitter), Facebook, LinkedIn, Instagram, and YouTube - ensures impactful outreach and engagement with diverse audience segments across the Country.

Events, inaugurations, award ceremonies, and workshops are prominently showcased through live social media updates, YouTube streams, and webcasts, enabling real-time interaction and participation. Initiatives and programs from NIC's State and District Centres are also regularly featured, amplifying visibility and strengthening NIC's digital presence across regions.

## 9.6 National e-Governance Division (NeGD)

NeGD is an independent Business Division (IBD) within Digital India Corporation (erstwhile Media Lab Asia), under MeitY. NeGD's major operational areas include programme management, project development, technology Management, capacity Building, awareness and communications related activities under Digital India Program. NeGD provides technical and advisory support to Central Ministries / Departments, State Government Departments and other Government Organisations in their Digital India activities. NeGD has developed and is managing several national public digital platforms such as Digilocker, UMANG, Rapid Assessment System, OpenForge, API Setu, Poshan Tracker, Academic Bank of Credits, National Academic Depositories, National AI Portal, MyScheme, India Stack Global, Meri Pehchan, etc. The details may be seen at Chapter 2.

### 9.6.1 Awareness & Communication Division (Jan 2026)

The Awareness and Communication (A&C) Division at the National e-Governance Division (NeGD) plays a pivotal role in amplifying Digital India initiatives across the country. The A&C Division is responsible for conceptualising and executing integrated communication strategies encompassing awareness campaigns across different types of media, workshops, conferences, exhibitions, digital content, and citizen outreach programmes.

The A&C team works closely with academic institutions, industry bodies, State Governments, MeitY Divisions, and other Ministries and Departments to ensure that Digital India initiatives reach various stakeholders including citizens, students, startups, and government through content dissemination in myriad forms. The Division leads creative content creation, designing and branding exercise, execution of key events, sustained digital and social media amplification media coordination, and communication support for national and international conferences/summits, product launches, and global showcases.

The A&C Division successfully organised and supported a wide range of national and international events, workshops, State consultations, university outreach programmes, exhibitions, and awareness initiatives to promote key Digital India programmes.

## 9.6.2 Major Events

### Regional Open Digital Health Summit 2025

**November 19–21, 2025 | New Delhi**

The Regional Open Digital Health Summit 2025 was organised by the National e-Governance Division (NeGD) in collaboration with the National Health Authority (NHA), WHO-SEARO, and UNICEF. The Summit focused on accelerating the adoption of open, interoperable, and people-centric digital health ecosystems across the South-East Asia region.

### Digital India Pavilion at the 44th India International Trade Fair

**November 14–27, 2025 | New Delhi**

Union Minister of State for Electronics and Information Technology, Shri Jitin Prasada, inaugurated the Digital India Pavilion at the 44th India International Trade Fair (IITF) on 14 November 2025. The Pavilion showcased India's journey in building a secure, inclusive, and citizen-centric digital ecosystem.

Located at Hall No. 6, the Pavilion featured key e-Governance initiatives such as DigiLocker, UMANG, myScheme, NIXI, NIELIT, CERT-In, India Semiconductor Mission (ISM), and Aadhaar. The exhibits highlighted the impact of Digital India in fostering transparency, inclusion, and digital empowerment, in line with the IITF 2025 theme "*Ek Bharat, Shreshtha Bharat.*"

NeGD was awarded the **Silver Medal** by ITPO in the category of Ministries, PSUs, and PSBs for the Digital India Pavilion.

### National Conference on DigiLocker

**November 4, 2025 | New Delhi**

The National Conference on "*DigiLocker – Enabling Paperless Access for All*" was organised by NeGD, MeitY, at Bharat Mandapam, New Delhi. The Conference brought together senior government officials, leaders from the technology and financial sectors, educationists, and digital governance experts.

The discussions highlighted DigiLocker's evolving role from a secure document storage platform to a cornerstone of trust, convenience, and efficiency across governance, education, and industry, reinforcing India's Digital Trust Revolution.

### India Mobile Congress 2025

**October 8, 2025 | Yashobhoomi, New Delhi**

Prime Minister Shri Narendra Modi inaugurated the 9th edition of the India Mobile Congress (IMC) 2025, Asia's largest telecom, media, and technology event. IMC 2025 showcased advancements in telecom and emerging technologies, with participation from global leaders, policymakers, industry experts, and innovators.

The event witnessed participation from over 1.5 lakh visitors representing 150+ countries, 7,000+ delegates, and 400+ companies. Over 1,600 use-cases across 5G/6G, AI, smart mobility, cybersecurity, quantum technologies, and green tech were showcased through 100+ sessions and 800+ speakers.

### **28th National Conference on e-Governance**

#### **September 22–23, 2025 | Visakhapatnam, Andhra Pradesh**

The 28th National Conference on e-Governance (NCeG) was jointly organised by the Department of Administrative Reforms and Public Grievances (DARPG), MeitY, and the Government of Andhra Pradesh, with IIM Visakhapatnam as the Knowledge Partner.

The Conference theme, “*Viksit Bharat: Civil Service and Digital Transformation*,” featured six plenary and six breakout sessions and brought together senior officials, policymakers, academia, industry experts, and awardees to deliberate on innovative practices and emerging trends in e-Governance.

### **IndiaAI Impact Summit 2026 – Pre-Event**

#### **September 18, 2025 | New Delhi**

NeGD organized a mega pre-summit event at Hotel Ashok, New Delhi on September 18, 2025. At the event, Hon’ble HMEIT unveiled the logo and flagship initiatives for the IndiaAI Impact Summit 2026 in the presence of senior MeitY officials, global AI experts, and distinguished dignitaries.

Hosted for the first time by a Global South nation, the India AI Impact Summit is guided by the principles of *People, Planet, and Progress*, and structured around seven thematic pillars: Human Capital; Inclusion for Social Empowerment; Safe and Trusted AI; Science, Resilience, Innovation and Efficiency; Democratizing AI Resources; and AI for Economic Development and Social Good.

### **Semicon India 2025**

#### **September 2 - 4, 2025 | Yashobhoomi, New Delhi**

Prime Minister Shri Narendra Modi inaugurated *Semicon India 2025*, aimed at accelerating India’s semiconductor ecosystem. With participation from industry leaders and experts from over 40 countries, the event highlighted India’s growing capabilities, innovation potential, and global trust in building the semiconductor future.

### **28th National Exhibition – “Pledge to Make India a Golden Nation”**

#### **August 21–24, 2025 | Kolkata**

NeGD participated in the 28th National Exhibition organised by the Central Calcutta Science & Culture Organization for Youth. The exhibition showcased key Digital India initiatives including DigiLocker, EntityLocker, myScheme, and UMANG.

### **IT Secretaries’ Conclave 2025**

#### **July 15, 2025 | Bharat Mandapam, New Delhi**

MeitYorganised the IT Secretaries’ Conclave to strengthen collaboration among States and the Centre. Senior officers deliberated on emerging technologies, best practices, and strategies related to Aadhaar, cybersecurity, indigenous data centres, and the India Semiconductor Mission.

### **Osaka World Expo 2025**

#### **April–October 2025 | Osaka, Japan**

At the Osaka World Expo 2025, the India Pavilion “*Bharat Mandap*” was ranked among the top five most admired

pavilions, alongside the USA, Italy, France, and Japan, based on feedback from officials, visitors, and social media engagement.

### ECMS Guidelines and Portal Launch

#### April 26, 2025 | New Delhi

Hon'ble Minister Shri Ashwini Vaishnaw launched the guidelines and online portal for the Electronics Component Manufacturing Scheme (ECMS), marking a significant step towards strengthening India's electronics manufacturing ecosystem.

### Stakeholder Consultation on AI Readiness Assessment Methodology (RAM)

#### April 8, 2025 | Hyderabad

UNESCO, in collaboration with IndiaAI and the Government of Telangana, organised a stakeholder consultation on AI RAM. The initiative aims to develop an India-specific AI policy framework promoting responsible and ethical AI adoption.

### 9.6.3 Workshops, Conferences, and Consultations

- The division conducted **20+ University Workshops** across premier institutions including IIT-BHU, NIT Durgapur, IIIT Delhi, LSR, IIPS Mumbai, University of Lucknow, IP University, Amity University, and others:
  - Digital India Talkshow in Kohima Science College , Nagaland July 17, 2025
  - Digital India Talk Show at Pondicherry University July 30, 2025
  - Digital India Talk Show at IIPS, Mumbai August 21, 2025
  - Digital India Talk Show at Lady Shri Ram College, Delhi August 26, 2025
  - Digital India Talk Show at Maharaja Agrasen Institute of Technology, Delhi Sept 12, 2025
  - Digital India Talk Show at University of Lucknow Sept 16, 2025
  - DI Talk Show at Ajay Kumar Garg Engineering College, Ghaziabad Oct 09, 2025
  - Digital India Awareness Workshop (DI Talk Show) at Galgotias University, Greater Noida Oct 17, 2025
  - Digital India Talk Show cum Interactive Session at ITS Mohan Nagar, Ghaziabad Dec 12, 2025
- **State-level consultation workshops** were conducted in Kerala, Nagaland, Puducherry, Meghalaya, Madhya Pradesh, and Uttar Pradesh.
- The division supported MeitY consultations on API on-boarding, DPDP Rules 2025, AI datasets, UX frameworks, AI RAM, and regulatory reporting.

### 9.6.4 Programmes and Shows

#### Ask Our Experts

The A&C Division conducts “Ask Our Experts”, a weekly live webcast series every Friday covering Digital India initiatives. As of January 2026:

- **Episodes conducted:**39
- **Total impressions:** 61.6 lakh
- **Total watch time:** 8,293.5 hours
- **Top viewership:** India, USA, UAE

Topics included Digital Identity, Cybersecurity, IndiaAI Impact Summit, Semicon India, DigiLocker, UMANG, BHASHINI, DPDP Act, Quantum Security, women's safety, and citizen-centric digital services.

### 9.6.5 Social Media and Digital Outreach

The Social Media team delivers consistent, high-impact communication across platforms, covering DigiLocker, IndiaAI, CERT-In, UPI, data protection, cyber safety, handloom, capacity building, AI, and citizen-centric digital awareness.

#### Social Media Reach:

- Digital India (X): 2.1+ million
- Digital India (Facebook): 1.4 million
- Digital India (Instagram): 541K
- Digital India (LinkedIn): 103K
- Digital India (YouTube): 82.8K
- MeitY (X): 1+ million
- MeitY (Facebook): 233K

### 9.6.6 Other Key Activities

- Communication and branding support for Bharat Tex 2025, Convergence India Expo, AI dataset workshops, UX sensitisation programmes, DPDP Act awareness workshops, and IndiaAI Impact Summit pre-events, Working Group Meetings etc.
- End-to-end creative design work and video production work for social media, events, and launches
- Designing of books, brochures, pamphlets, standees, backdrops
- Procurement of merchandise for distribution to various stakeholders and vendor coordination for communication and branding requirements across major events.

The Awareness and Communication Division continues to play a critical role in strengthening citizen engagement, stakeholder outreach, and visibility of Digital India initiatives, reinforcing MeitY's vision of inclusive, transparent, and technology-driven governance.

## 9.7 Standardization Testing and Quality Certification Directorate (STQC)

### 9.7.1 Introduction

Standardisation Testing and Quality Certification (STQC) Directorate, an attached office of the Ministry of Electronics and Information Technology, Government of India, provides Quality Assurance services in the area of Electronics and IT through countrywide network of laboratories and centres. The services include Testing, Calibration, IT & e-Governance, Certification & Capacity Building to government, Public and Private organizations. STQC has been pioneer in the country for QMS, ISMS certification as per ISO 9001, ISO 27001. STQC labs/Centres are having National / International accreditation and recognitions in the area of IT Services, e-Governance, Testing, Calibration, Training and certification services.

STQC operates a nationwide network of ERTLs, ETDCs and IT Centres. In addition, STQC has specialized centres like Centre for Reliability (CFR) and Indian Institute of Quality Management (IIQM) which offer training programs pertaining to reliability and quality Management services respectively.

Over the last four and half Decades, STQC has established itself as a pioneer in the field of Testing, Calibration, IT & e-Governance, Training, Certification and providing nationwide support to various government, Public and Private organizations including Startups, MSME etc. Major clientele STQC served are: Central Government Ministries / Departments /State Governments, R & D organizations (DRDO, ISRO) Défense (Indian Army, Navy, Airforce) Telecom (DoT, TRAI) Power (Power Grid, CPRI) Railway (Indian Railways & Metro Rail) PSUs (IOC, NTPC, Coal India, BHEL, SAIL etc) Recruitment agencies (SSC, State Bodies) Statutory Bodies (e.g., BIS, UIDAI, Cert-In etc.) and many more.

### 9.7.2 STQC Labs/ Centre

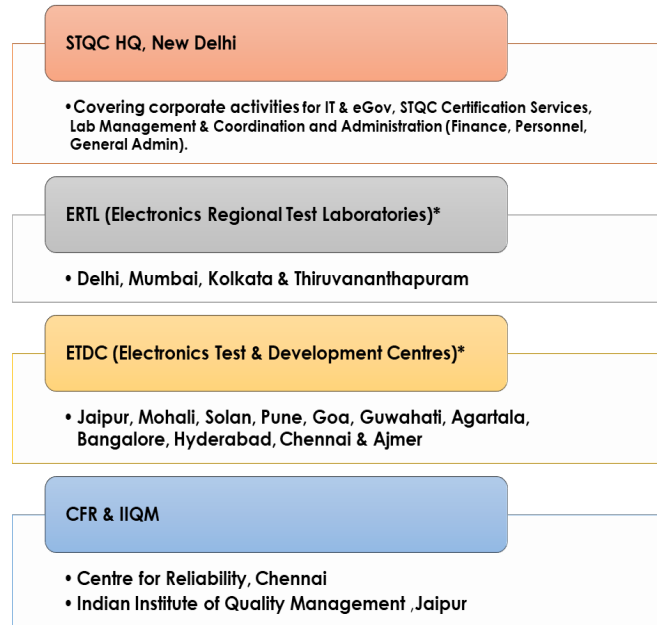

### 9.7.3 Activities /Services of STQC

#### a. IT & e- Governance

##### IT System & Product Certification

- CCTV camera Testing and Certification
- IoT System Certification
- Common Criteria Certification
- Website Quality Certification
- Trusted Electronics Value Chain Certification
- E-Procurement System Certification (EPS)
- Bio-metric Devices Testing and Certification
- Toll Management System Certification

##### Software & System Testing

- Software Testing and Assessment
- Software Process Assessment

- Information Security Testing and Assessment
- Software Functional Testing
- Application Performance Testing
- Application Security Testing
- Mobile app Security testing
- API Security Testing
- Vulnerability Assessment & Penetration Testing
- Acceptance Testing of e-Governance Projects
- Independent Verification and Validation
- Usability Testing
- Accessibility Testing
- Embedded Device/Software Security Testing
- Source Code review
- Drones Security and performance Testing

**e-Governance Conformity Assessment**

- Quality Assurance Framework
- Scheme for Empanelment of Cloud Service Provider
- Scheme for Empanelment of e-Gov. Software Test Labs

**b. Electrotechnical Testing**

- Component Testing of SMDs (passive and active, VLSI devices)
- Equipment/Subsystem and Module Testing
- Environmental and durability Testing
- Testing for Safety of Electronics/Electrical products
- EMI/EMC Testing
- Opto Electronics product Testing
- Reliability Testing and Analysis
- EVM /VVPAT Testing
- Medical Electronics equipment testing
- Power / Energy meter Testing
- UPS Testing

**c. Calibration**

- Electro Technical Calibration
- Non-Electrical Calibration
- High Precision Calibration
- RF Calibration

- Optical Calibration,
- EMI/EMC Calibration
- Bio-Medical Equipment Calibration

#### d. Certification

##### Management System Certification

- ISO 27001 Information Security Management System (ISMS) Certification
- ISO 9001 Quality Management System (QMS) Certification

##### Product Certification

- Product Safety Certification based on IEC Standards (S mark)

#### e. Capacity Building

- Quality Management Programs as per ISO: 9001:2015
- ISMS LA program as per ISO: 27001:2022
- Laboratory Management Programs as per ISO: 17025:2017
- Reliability Engineering Programs
- Common Criteria evaluation
- Information Security
- E-Governance Quality Assurance
- Measurement Uncertainty
- Training program on various area of technology in Testing and Calibration

### 9.7.4 Major Activities / Achievements

#### 9.7.4.1 STQC Hq., New Delhi

##### I. IT & e- Governance

###### • Indian Common Criteria Certification Scheme (IC3S):

Indian Common Criteria Certification Scheme (IC3S) is operated by STQC Directorate, (MeitY), Govt. of India. The purpose of this scheme is to evaluate and certify IT Security Products and Protection Profiles (PP) against the requirements of Common Criteria Standards, at assurance levels. Wide ranges of IT products such as network devices, operating system, etc. are certified for security features under this scheme.

STQC represents India in CCRA (Common criteria recognition agreement) as a Certificate Authorizing Nation.

STQC personnel has participated as an observer in VPA of Cyber Security agency of Singapore (CSAS) at Singapore.

Further, STQC (representing India) has also participated in CCRA meeting held at South Korea.

02 Certificates issued under this scheme in 2025.

###### • Biometric Device Certification Scheme (BDCS):

STQC Directorate has been entrusted by Unique Identification Authority of India (UIDAI) as a quality assurance partner. The objective of Biometric Device Certification Scheme (BDCS) is to perform assessment/evaluation and subsequent certification of Biometric Devices and to facilitate availability of quality assessed Pre-certified Hardware,

authentication/ enrolment Biometric Devices along with QR Code scanner device for offline authentication to user agencies like AUAs/KUAs as per Aadhaar Act.

STQC is the only Conformity Assessment body to verify the compliances of Bio-metric Devices for Aadhar ecosystem.

14 Certificates issued under Biometric Device Certification scheme in 2025.

- **Website Quality Certification Scheme:**

Website Quality Certification Scheme is based upon National and International Standards/Best practices. The certification scheme aims to help in hardening of websites from wide range of Security threats. Further the scheme is also intended to enhance accessibility, assuring commitment to services and ensuring compliance to the requirements of Guidelines for Indian Government Websites (GIGW) developed by National Informatics Centre (NIC) and adopted by Department of Administrative Reforms and Public Grievances (DARPG), Government of India.

Websites of various ministries/departments has been certified under this scheme are 48.

- **IoT System Certification Scheme (IoT SCS):**

The objective of this scheme is to promote security of IoT ecosystem. This scheme will facilitate improvement of National Cyber Security profile.

The implementation of this Certification Program will provide confidence to users that the risks associated with the threats currently set forth in the IoT-SCS are addressed by a device/system provider through conformance to this scheme. Demonstration of conformance through this certification program provides formal recognition of a conformance to the industry standards.

MeitY has entrusted STQC to conduct Testing, Audit & Certification of CCTV Camera Under PPO and Certificates issued under PPO in 2025 : 52.

BIS has empanelled only STQC labs for Testing/ Evaluation of CCTV Camera Under CRO Scheme. Models registered under BIS in 2025: 366

- **E Procurement System Certification Scheme:**

E-Procurement is identified as a mission mode project under national E-Governance plan. E Procurement System Certification is an integral requirement by Government envisaged by MeitY, CVC and other Govt Ministries. STQC has been entrusted for evaluation, assessment and Certification of EPS.10 Certificates are issued under EPS scheme in 2025

- **SAB- STQC Empanelled Test Laboratory (SETL):**

STQC Directorate is the designated approving body for the operation of the scheme. STQC maintains a management system in accordance with international practices (ISO/IEC 17011) and that its approved conformity assessment bodies are competent in their operations of testing and assessments.

The scheme is intended to recognize the competence of IT test laboratories and to provide confidence to the stakeholders that Test results of Solutions tested in these laboratories are reliable, reproducible and repeatable. Under the scheme, after satisfactory completion of the assessment, the laboratory is issued a 'Certificate of Approval' indicating conformance to specified requirements of applicable standards as specified in the scheme.

The scheme covers both private and public (Government) IT test laboratories involved in software and system testing with in-house and/or onsite capabilities. At present total 13 SETLs are empanelled by STQC.

- **Implementation of e-gov./digital India Initiatives**

STQC directorate has successfully implemented e-HRMS at its Headquarter and further it is in the process of being scaled up to its all labs and centres.

## II. Certification Division

- **Information Security Management System (ISMS) Certification Scheme:**

STQC is the first internationally recognized certification body of Indian origin in the country for Information Security Management Systems. This Certification Scheme is accredited by National Accreditation Board for Certification Bodies (NABCB), Quality Council of India since 2014. The information security management system preserves the confidentiality, integrity and availability of information by applying a risk management process and gives confidence to interested parties that the risks are adequately managed.

- **Quality Management System (QMS) Certification Scheme:**

QMS certification process involves a review of the Organization's Quality Management System and on-site audits by STQC. ISO 9001 standard promotes the adoption of a process approach when developing, implementing and improving the effectiveness of a Quality Management.

Through this scheme, a range of entities—including research and development organizations, academic institutions, and IT companies—are granted certification, empowering them to adopt a process-oriented methodology and enhance the efficiency of their service delivery.

- **Safety(S-Mark) Certification Scheme:**

Safety Certification ('S' Mark) scheme is a third-party Certification scheme in Electronics sector operated by STQC Certification Services and accredited by NABCB, India. This scheme is intended to provide adequate level of confidence, by means of system assessment, product testing and subsequent surveillance of the manufacturer, that the product conforms to the specified requirements of appropriate Safety standard published by International Electro-technical Commission (IEC).

- **Assessment of Cloud Service Providers**

MeitY has entrusted STQC Directorate for assessment of Cloud Service Providers (CSP) as per MeitY CSP Empanelment scheme. Cloud service offerings of Cloud Service Providers (CSPs) are empanelled with the Ministry of Electronics and IT (MeitY) for three Cloud deployment models, namely: Public Cloud, Virtual Private Cloud (VPC) and Government Community Cloud (GCC); and three service models: Infrastructure as a Service (IaaS), Platform as a Service (PaaS) and Software as a Service (SaaS).

- **Assessment and notifications of Digital Forensics labs as Examiner of Electronics Evidence**

MeitY has entrusted STQC Directorate for assessment and evaluation of Forensic science laboratories for notifying as "Examiner of Electronic Evidence" as per provision under Section 79A of Information Technology Act 2000.

MeitY under a scheme for the above purpose has notified 21 labs till date as Examiner of Electronic Evidence as provisioned Under Section 79A of IT Act 2000 upon assessment and evaluation of applicant laboratories by STQC auditors.

STQC has also been entrusted to conduct annual surveillance assessment of notified laboratories and is carrying out surveillance assessments regularly.

### 9.7.4.2 ERTL(North), New Delhi

#### i) IT Services

- **Smart Cities**

Comprehensive audits conducted across multiple smart city infrastructures encompassing IoT, surveillance, traffic management, and centralized command centres.

- **Assessment of CCTV Systems**

Security evaluations were completed for various camera models from different vendors.

Assessment of PSP 2.0

The second version of Passport Seva Program underwent detailed functional and security testing, ensuring reliable, easy to use and secure citizen-centric service delivery.

L1 Biometric Device Certification

Multiple Level-1 biometric authentication devices were successfully tested and certified for compliance with UIDAI requirements.

- **Assessment of BSS for Indian Defence Forces**

Mission-critical Battlefield Surveillance System (BSS) was assessed for operational resilience.

Income Tax Portal Assessment

Next-generation ITD systems were evaluated to meet compliance, performance, security and integrity requirements.

Assessment of e-Migrate v2.0

Comprehensive assessment of the e-Migrate platform for secure handling of migrant worker data.

ERTL(N) has established basic level Side Channel Testing facility.

#### ii) Electrotechnical Testing Services

- **Safety Testing:**

Product Safety Assessment: The lab conducts comprehensive safety assessments of various products to identify potential hazards, evaluate risks and ensure compliance with safety regulations and standards. It is a statutory obligation in most cases. Under this assessment parameters such as electrical safety, mechanical safety, thermal safety, radiation safety, fire safety, and ergonomics are assessed to ascertain the safety performance of the products.

- **Laboratory Accreditation / recognition for safety testing:**

1. Accreditation under NABL scheme as per ISO/IEC 17025-2017- Testing of products as per different IEC & IS standards like IEC 60227 & Part 1-5, IEC 60335-1, IEC 60335-2-14, IEC 60335-2-31, IEC 60335-2-65, IEC 60335-2-80, IEC 60335-2-109, IS 302-1, IS 302-2-6, IS 302-2-14, IS 302-2-15, IS 302-2-26, IS/IEC 62368-1, IS 10322-5-6, IS 10322-5-7, IS 10322-5-8, IS 10322-5-9, IEC 61347-2-13, IS 15885-2-13, IEC 62560, IS 16102-1, IS 15111-1, IS 16103-1, IEC 61010-1, IEC 62052-31, IEC 60950-1/IS 13252-1.
2. BIS Recognition-Testing of products as per IS 13252-1 / IEC 60950-1, IS 616 / IEC 60065, IS 15885-2-13, IS 10322-5-6, IS-10322-5-7, IS-10322-5-8, IS 10322-5-9, IS 16102-1 standards.
3. S mark Recognition: Testing of products as per IS 13252-1 / IEC 60950-1.
4. TEC Recognition Testing / Evaluation of products as per IS 13252 / IEC 60950-1 standard.

- **EMC Testing**

**Innovation and Design in India:**

A Digital RF Power Meter, designed and developed to operate up to 6 GHz, was an invaluable addition to the EMI/EMC test Lab. As RF Power Meters are critical instruments in any EMC/RF laboratory, the RF Power Meter developed in house helped the lab to meet the required standards, during many audits like NABL while showcasing scientific innovation and problem-solving capabilities within the facility.

**Technology and Application Development:**

An Antenna Mast Controller was designed in-house to replace the faulty controllers at ERTL (North), New Delhi, and ETDC, Bangalore. This equipment is essential for conducting Radiated Emission Testing in an Anechoic Chamber and was developed within a budget of under ₹1,500. In comparison, similar commercial products are priced at over ₹15 lakhs, highlighting the cost-effectiveness and innovation of this solution.

A microcontroller-based Comb Generator/Reference RF Emission Source was designed and developed for use in the Conducted Emission setup and Inter-Lab Comparison (ILC) studies, at a cost of under ₹1,000. In contrast, similar commercial products are typically priced between ₹2–3 lakhs, underscoring the innovation and cost-effectiveness of this in-house development.

- **Environmental Testing lab**

**Details of major activities /initiatives/ Achievements**

The Environmental lab of ERTL (North) has successfully installed and commissioned a Mechanical Shock Test Machine, expanding its capability to perform shock testing from 10g to 1500g with half-sine & peak saw-tooth waveform support. This installation has significantly upgraded the laboratory's service portfolio and aligns its capabilities with international standards.

- **System Testing**

The lab is equipped with necessary facility required for Energy meter testing and maintain NABL accreditation.

Further lab has also carried out testing of Automatic Line Voltage corrector, UPS, Fire alarm Panel, LED lamp, control panel, Interactive flat panel, Franking machine etc.

- **Calibration Services**

The High Precision Calibration Centre (HPCC) Laboratory at ERTL(N), New Delhi offers calibration services to Industries/Govt. organizations/PSUs in the field of Electro-Technical, Mechanical, Thermal & Optical parameters. The laboratory is equipped with reference standards of high accuracy and precision in the field of Power/Energy calibration, DC/AC voltage and Current, RF Parameters, RLC standards, Frequency Standard, Dead Weight to Dead Weight Calibration System, Fixed Point Temperature Calibration of SPRTs, High precision Temperature Calibration System, 'O' Grade Dimension Metrology Standards, Walk- in Environment Chamber Calibration System, Vibration and High Precision Weight Calibration System.

ERTL(N), by complying with the requirement of ISO/IEC 17025 standard, is competent to produce reliable and valid results. NABL Accreditation of laboratory ensures compliance to ISO/IEC 17025 standard.

The lab has commissioned oscilloscope 4 Ghz. and Power/ Energy Reference Meter with high accuracy. The lab is catering to various PSUs and Private industries.

**Support to MII Initiatives**

More than 45 Development Assistance projects were successfully delivered to industries, covering "Make in India" products such as drones, robotics, level transmitters, IoT devices, airport landing guidance systems, e-bikes,

electromechanical antenna masts, rope lights, fog-safe devices, and wellness products like body massagers for malls and airports.

A Total of 73 compliance test jobs was conducted to assess adherence to EMI/EMC standards for different types of products across various industries, ensuring that their products meet the required regulatory norms. Some of the tested equipment includes Teleportation Relay, Grid IoT Devices for grid monitoring, E-Bike, Smart Energy Meters, Security Cameras, Biometric Authentication devices such as IRIS and Fingerprint Scanners, Managed PoE Switches, DMRC LED Lights, Gas Release Panels, Video Processors with Endoscopes, Solar String Monitoring Systems, Fire Alarm Control Panels, SMPS-based Power Plants (450A), and Power Line Communication Equipment (HFCL).

#### 9.7.4.3 ERTL(East), Kolkata

##### i) **IT Services**

Completed 16 nos of CVC and IT Conformity assessment of e-Procurement application, e-Bidding application and e-Auction application of different organizations. The systems are successfully used in electronic procurement and different e-Bidding / e-Auction exercises of Govt. of India.

Performance Testing of Skytron Vehicle Tracking application, Govt. of Assam.

Conducted functional testing, security audit, SLA audit, performance testing, BoM verification, SOC audit, NOC audit, VA, API security, mobile apps security of Financial Intelligence Unit.

Completed Vulnerability Assessment of network infrastructure of Newtown Kolkata Development Authority, Bharat Heavy Electricals Ltd. Mahanadi Coalfields Ltd., Commissioner of Treasuries & Accounts, Department of Finance, Govt. of MP, NCDEX e-Markets Ltd. for around 1000 hosts.

Carried out penetration tests on 16 internet-facing IP Addresses, along with vulnerability assessments of critical infrastructure of Centre for Railway Information Systems (CRIS).

Undertaken security assessment for websites of Indian Missions all over the world and no. of websites of different Indian Institute of Management (IIM), websites of Indian Missions all over the world.

##### • **Website Quality Certification**

ERTL (E) has completed assessment of 3 Website Quality Certification projects, 2 projects are about to be completed and 15 projects are ongoing.

No. of web applications / web sites from different departments like Dept. of Health & Family Welfare, Dept. of Women & Child Development and Social Welfare, Department of Environment, Directorate of Pension, PF & Group Insurance, Finance Department, Govt. of West Bengal, State Council of Educational Research & Training (SCERT) , West Bengal Minorities' Development & Finance Corporation, Government Opium and Alkaloid Factories, Ministry of Finance, Govt. of India, Commissionerate of Taxes, Govt. of Assam, Office of the CEO, Govt. of West Bengal, Ministry of Jal Shakti, Govt. of India, MECON Ltd. have been assessed for security vulnerabilities and cleared for 'safe to host'.

Undertaken security assessment of the mobile apps used by Indian Railways, West Bengal Minorities Development & Finance Corporation for Term Loan, e-Rakshak and e-Vivechana for MP Police.

Monitoring of temperature and humidity of the Data Centre has been done using IoT module and alert is generated upon reaching threshold value and mails are sent to the custodians.

- **Common Criteria (CC) Testing**

Common Criteria (CC) EAL3 evaluation of CDoT Encryptor Module (CEM) was conducted and evaluation of 12 other projects is in progress.

- **Certification service offered**

ERTL(E) is managing Regional certification cell East for the certification activities pertaining to STQC Certification services.

Quality Management System certification as per ISO 9001:2015 standard, served industries in the Eastern region which includes Govt. organizations (Integrated Test Range (ITR), Proof and Experimental Establishment (PXE), CDAC, Kolkata etc.), Pvt. Organizations (Calcutta Business School, Marshal Geo, etc.).

Information Security Management System certification as per ISO/IEC 27001:2022 standard, served industries in the Eastern region which includes Govt. organizations (CDAC, MSTC, Tripura SLDC etc.), Pvt. Organizations (Mjunction, DCG Data core System etc.).

S mark (PCB) Certification for product certification for Safety marking as per IEC standards, served three industries (Genus, Bentick), 7 products have been certified.

## ii) **Electrotechnical Testing Services**

- **Energy Meter Test facility**

Energy Meter Test facility to adopt 2020 edition of IS 13779 & 2021 edition of IS 14697 and received BIS Recognition under LRS scheme and also achieved NABL accreditation for latest revision of IS: 13779:2020 and IS: 14697:2021.

Type testing of Energy Meters & Tri-Vector Meters of various types up to 100A (Imax) has been conducted for major Indian Manufacturers under Licensing Scheme of BIS and requirements of Electricity Boards across the country

- **Environmental Testing**

Climatic conditioning, Mechanical endurance & Ingress Protection tests on Electrical/Electronic Equipment/ System for Telecom, Defence, Railway & other Industrial applications has been conducted regularly

Lead Acid Battery and PV Module testing facilities are maintained and different jobs has been conducted to support Non-Conventional Energy movement initiated in the country.

- **EMI/EMC Testing**

Conducted radiation power measurement, surge test, conducted emission test, ESD Test and Radiated susceptibility test as per national/International standard.

Surface Industries dealing with hydro-carbon and other combustible materials as per revised edition of IS/ IEC 60079-series for BIS Product Certification and DGMS & PESO approval.

## iii) **Calibration Services**

ERTL(E) is Maintaining NABL accreditation for Electro-Technical, Optical and Non-Electrical Calibration facility as per 2017 edition of ISO/IEC17025.

Facility for calibration of precision 8.5 Digit Digital Multimeter, AC DC Current up to 100 A, AC Current Clamp up to 6000A.

Conducted RF power meter calibration up to 100 W for frequency 10MHz to 1000 MHz for Airport Authority of India, Indian Air Force etc.

Specialised Calibration services for Avionics equipment has been provided to Air Traffic Control of Airport Authority of India across the country Laboratory is able to provide NABL accredited calibration services to the industries for Optical Power Meter, Optical Source and Optical x,y Colour Coordinate, Colour Temperature, Optical Wavelength and Illuminance.

Facility upgradation for calibration of Pressure by using Budenberg Dead Weight Tester.

#### 9.7.4.4 ERTL (West), Mumbai

##### i) IT Services

Evaluation of multiple CCTVs for Essential Requirement(s) for Security of CCTV as per ER01:2024.

Evaluation of Rajkot and Dahod Smart City for Process Audit, TEVCCS, End Point Security and VAPT testing.

Delivered services of Functional Testing, Performance testing, GIGW testing, IT infrastructure audit (hardware and software), VAPT and Application Security Testing to Govt and Private sector organizations.

Successfully completed GIGW 3.0 audit of The President of India and Rashtrapati Bhavan website

GIGW testing of Government department Site – NABARD, ESIC, Indian embassy Qatar, Central Bank of India etc. (Round 1)

Cloud service provider Audit as per MeitY guideline.

Carried Application security audit for RRB website.

##### ii) Electrotechnical Testing Services

###### • EMI/EMC Testing

Following are some examples of EMI EMC evaluations done at ERTL (W), Mumbai to meet various national and international regulations.

Various In-Vitro bio medical instruments were tested like Cliniquant, Blood Chemistry Analysers, Automated Immunoassay Analyser etc.

An Electric Vehicle (EV) Charger - An electric vehicle battery charging system for Conducted Emission , Radiated Emission, Conducted RF Susceptibility, Radiated RF Susceptibility, Electric Fast Transients/Burst , Surge, Electrostatic Discharge, Power Dips and Interruptions, Power Frequency Magnetic Field , etc. This in turn is being encouraged for use of green energy.

Single Rail Tester used for the manual Ultrasonic testing of the rails/ welds of the railway tracks.

Environmental Radiation Monitor with Detector assembly evaluated for Radiated Emission, Radiated RF Susceptibility and Electrostatic Discharge.

###### • Radiated Emission tests for LED Lights

Logo Device – a device to display Agra-Kanpur Metro DTD Logo on Metro train verified for Conducted Emission, Radiated Emission Conducted and Radiated RF Susceptibility, Electric Fast Transients/Burst, Surge and Electrostatic Discharge.

###### • Equipment & Subsystem Testing

The laboratory has carried out Type testing of Static Single phase and three Phase energy meter, whole current & CT operated (Normal Prepayment type) as per IS 13779/14697/15884 covering safety requirements, performance and performance of meter under influence conditions like EMI/EMC, Climatic and mechanical durability requirements. The type test facilities are extensively used by Indian Energy Meter manufacturer for

improvement and benchmarking their products. This helps Indian industry to compete the product in quality globally. ERTL (W) has uploaded Numbers of test report leading to BIS Certification.

The Laboratory has tested Fire alarm System for its compliance to safety requirement. The laboratory has tested Battery Charger system as per Telecom Department and Airport authority regulatory requirements.

The laboratory is developing full facility for Smart Energy Meters Testing as per IS 16444 for BIS Certification.

- **Environmental Testing**

Conducted Environmental Stress Screening (ESS) testing on locally manufactured products such as Assembled Printed Circuit Boards (PCBs) and modules, contributing significantly to Indian Defence Projects. Performed Climatic, Mechanical, and Ingress Protection (IP) testing on multi-pin circular connector pairs, crucial for Indian Railways' operations and safety.

Conducted Climatic and Mechanical testing on B-scan Ultrasonic Double Rail Testers and Multiscan SR09 units, which play an essential role in ensuring the safety of Indian Railways.

Conducted thermal cycling tests on the PK-68M-I PANEL, an essential component for ground-level testing of the SU-30MKI Fighter Aircraft, enhancing the testing capabilities for India's defense sector.

Performed Climatic, Mechanical, and Ingress Protection (IP67) testing on the Agra-Kanpur Metro DTD Logo, ensuring its durability and performance for the Agra-Kanpur Metro network.

Conducted vibration tests on critical components such as the Manual Shut-Off Valve (Bellow Sealed Type), Manual Control Valve (Bellow Sealed Type), and Ball Valve (Gland Sealed Type) from Baldota Valves & Fittings, ensuring their suitability for Nuclear Power Corporation of India Limited (NPCIL) projects.

- **Safety Testing**

Surveillance Testing as per IS 13252(part1), IS 616, IS 15885-2-13 for Mobile phone, Tablet, Power adaptor, wireless Headphone and Earphone, Cosmic Byte Keyboard, WEB CAM, Digital Camera, Dc or Ac supplied electronic control gear.

Review of Surveillance Report of so many products such as power adaptor, mobile phone, Wireless headphone and earphone, Tablet, Automatic data processing machine etc

Testing of Electromechanical Relay as per IEC 60255-27

Testing of Standoff insulator for High Voltage test and Insulation Test

Testing of Moisture Analyzer and Clean Room Monitor as per IEC 61010-1

Testing of Insta explor, CLOT Xplor, URI Quick, Automated ESR Determination Analyzer as per IEC 61010-2-101.

Testing of equipment Data logger as per IEC 61010-1

Testing of Merilyzer Autoquant and Merilyzer Cliniquant Pro as per IEC 61010-2-101

- iii) **Calibration Services**

Facility extension for Oscilloscope calibration from 600 MHz BW to 1.1 GHz BW after incorporating 5522 A Multi-function Calibrator with 1.1 GHz Oscilloscope option. Now calibration of Bandwidth parameter for Digital Oscilloscope possible to be carried out up to 1.1GHz Bandwidth.

Calibration Services of ERTL(W) extended to Aircraft Maintenance division Airports Authority Of India for Calibration of Avionics instruments like IFR 4000, IFR 6000, Chart Recorder, N/I module and Wide Frequency Receiver.

ERTL(W), Mumbai provided accredited Calibration services to Universal Instrument Pune, IDEMI Mumbai, ETDC Pune, ETDC Goa, BARC Mumbai, L&T Mumbai to maintain traceability to their Master Instruments as well as Automatic Research Association of India Pune, IIT Mumbai, SAMEER, & Electronics Manufacturing Industries for their precision instruments.

Obtained NABL accreditation for ILC participation for different Electrical Calibration parameters.

Specialized High Voltage set up is exclusively available with ERTL(W) and facilities are being used by industries and PSUs (SIEMENS, BHEL etc.)

#### iv) **Certification Services**

The Certification Services in the West Region are being provided by Regional Certification cell (west) located in ERTL(W) Mumbai and following services are being offered:

Management System Certification Schemes:

- ISO 9001 Quality Management System (QMS) Certification.
- ISO/IEC 27001 Information Security Management System (ISMS) Certification.

**Product Certification Schemes:**

- Product Safety Certification based on IEC Standards (S mark)

#### 9.7.4.5 ERTL(South), Thiruvananthapuram

##### i) **IT Services**

ERTL(South) is identified by the government of Kerala, as the third-party test centre, for carrying out the application security testing of the websites and web applications developed for the various state government departments which are being hosted in the Kerala State data Centres.

The lab successfully undertook comprehensive audits of multiple smart cities, ensuring the security and reliability of their digital ecosystems. The audit encompassed a wide range of activities, including security assessments of various web applications, mobile applications, and endpoint devices deployed within the smart city infrastructure. It involved in-depth vulnerability analysis of network infrastructure, Trusted Electronics value chain certification, and detailed process audits. Notably, the smart city audits for Thiruvananthapuram, Kochi and Thoothukudi were conducted by ERTL(S), demonstrating the lab's commitment to strengthening the security posture and operational efficiency of emerging smart city ecosystems.

The lab carried out evaluation and certification of CCTV cameras in accordance with Essential Requirements (ERs) notified in Gazette of India (EXTRAORDINARY, PART II—Section 3—Sub-section (ii) dated 7th March, 2024, at Sr. No. 1062) issued by MeitY. The standard mandates that all CCTV cameras manufactured or imported into India comply with stringent security requirements to safeguard against potential cyber threats. The lab is presently providing evaluation services and certification to various CCTV manufacturers, reinforcing its role in ensuring the deployment of secure and compliant surveillance systems across the country.

The lab carried out Comprehensive Security Audits (CSA) of national critical applications, following a rigorous 282-pointer checklist designed to ensure end-to-end security coverage. This audit evaluated key areas including application security, network security, data protection mechanisms, access control, regulatory compliance, incident response preparedness, and overall governance processes. The structured and detailed assessment helped to identify vulnerabilities and provided actionable recommendations to enhance the resilience and cybersecurity posture of these critical systems. The CSA audits of e-Sanjeevani and e-Shushrut applications were successfully completed, reinforcing ERTL(S) role in safeguarding national digital infrastructure.

ERTL(South) carried out Application Security Testing of major Software Applications viz., Pension portal, e-Kupay, e-Stamp, e-Treasury, BAMS, iSOFT, IFMS applications of Kerala Treasuries, Home Survey application of Scheduled Caste Development Department Kerala, KPSC Exams applications of Kerala Public Service Commission, K-CIS application of Kerala State Industrial Development Corporation, various modules in APT 2.0 application of Department of Post.

ERTL(South) carried out Website Quality / GIGW Compliance Testing for the web websites of Indian Space Research Organisation-Space Application Centre (ISRO-SAC), Department of Biotechnology, e-voting platform Right2Vote, National Cyber Crime Reporting Portal of Ministry of Home Affairs, official website of CERSAI (Central Registry of Securitisation Asset Reconstruction & Security Interest of India).

## ii) Certification Services

The lab provided critical support to the STQC certification body in carrying out various certification processes for multiple organizations. This included assisting in the Information Security Management System (ISMS) certification of UIDAI, PFMS, BHEL and Lubina Datamatix, ensuring these entities adhere to robust information security practices and standards. The lab also contributed to the Quality Management System (QMS) certification of ECIL, KELTRON, CDAC and ISTRAC, promoting consistent quality and operational excellence. Furthermore, the lab supported the Cloud Service Provider (CSP) certification of IBM, PiDatacentre and Ishan Infotech, validating the security and compliance of their cloud services. These efforts highlight the lab's expertise in enabling organizations to achieve and maintain internationally recognized certifications across diverse domains.

## iii) Electro-Technical Testing Services

ERTL(S), Thiruvananthapuram, continually participated in the Nationally Important Space Programmes in 2025 also, by undertaking Hi-Rel Components Screening, Packages & Modules testing and Environmental testing of Isolators and sub-assemblies.

ERTL (South) carried out Screening of more than 30 batches of discrete electronic devices used in important Space missions and Defence applications. The Lab also continued with the screening of Pulse Transformers, Crystal Oscillators, Linear and Digital ICs of different package formats, leaded as well as SMD technology for ISRO organizations viz. Vikram Sarabhai Space Centre (VSSC) and ISRO Inertial Systems Unit (IISU).

ERTL(South), Thiruvananthapuram recently developed a cutting-edge high power silicon diode screening facility to support OEMs engaged in indigenous strategic initiatives. The facility meets MIL-PRF-19500 standards and is capable of sourcing up to 400A DC — a unique capability in the high-reliability precision power electronics space.

The Lab has recently established screening facility for both Linear and digital integrated circuits (ICs), enabling qualification and evaluation of devices such as LM118H high-speed operational amplifiers, 74LVC14AD Schmitt-trigger inverters, 74LVC74AD dual D-type flip-flops, 74LVC06AD open-drain inverters, and SNJ54ACT244W octal buffers/drivers which includes diverse packaging technologies including SOIC, ceramic flat pack (CFP), and hermetic metal can packages, ensuring comprehensive coverage across commercial, industrial, and space-grade components.

The screening activities have been carried out for prestigious organizations such as IISU, VSSC, and NSIL, thereby reinforcing ERTL(S) role as a trusted partner in the reliability assurance of microelectronic components for critical space and defence applications.

ERTL (South) has been consistently engaged in testing and evaluation of Telemetry Systems, power supply modules, and Data Acquisition Systems for ISRO/VSSC's GSLV and PSLV programmes. The laboratory contributes significantly to the Gaganyaan Mission through the assessment of launch vehicle sub-assemblies. During 2025, ERTL (South) supported VSSC missions by successfully testing about 8 mini power modules, 5 ATS stacks, and 62 DAUs (DAU-I and DAU-II).

ERTL(S), under the Medical Electrical Equipment testing services, carried out testing of IOT based smart infusion monitor. IOT based medical devices are the emerging technological trend happening in the medical diagnostic and monitoring arena. The integration of IOT in medical devices makes risk assessment even more critical in nature which needs to be tested for software safety also. ERTL(S) with its fully equipped Software test facilities and trained manpower, took up this IOT based smart infusion monitor, thereby fulfilling the future needs of Medical software safety testing.

ERTL (South) carried out Environmental Screening of Isolators used for mounting various electronic packages of Space launch vehicle application. The Lab has also supported various start-ups in Environmental Testing and Vibration-related activities, thereby contributing to indigenous technology development. In addition, the Lab carried out Vibration Testing of Thermal Cameras for CDAC, further extending its support to advanced system development. The Lab also carried out Vibration Tests for VSSC and its subcontractors for testing of their packages and modules as per ISRO specifications. Furthermore, Environmental Stress Screening of PC boards used for defence applications was undertaken, ensuring reliability and mission-critical performance.

ERTL(S) is equipped with high-accuracy reference standards in the areas of DC/AC voltage and current, resistance (R), inductance (L), capacitance (C), frequency standards, and oscilloscope calibration. In 2025, the calibration facility expanded its services to cater to new sectors such as medical electronics and railway subcontractors, while continuing its support for space application projects and the automobile industry, including clients like M/s Tata Elxsi Pvt. Ltd. and M/s Quest Global Pvt. Ltd.

#### 9.7.4.6 ETDC, Bangalore

##### i) IT Services

Web Application Security Testing services were provided to Antares e-Procurement Application, Digifort VMS Software, Bengaluru ICCC Application for Fluentgrid Pvt Ltd Vishakaptanam, Trinity VMS Software, ISTEM Application, Honeywell VMS Software and Vicon VMS Software , HAL E- Tender Wizard, Department of Post Applications, OptiExacta VMS Application, NVR DVR Applications for NUUO Solutions Private Limited Bangalore, Intra stqc portal for STQC.

VAPT testing performed as a part of Smart Cities Security Audits. VAPT testing done for Antares network components, Video Surveillance system for RailTel Corporation of India Ltd., Department of Post.

Functional Testing for Akash Weapon System Simulator Classroom Prime, UP Telemedicine Vitalware.

Thick Client testing of Digifort Video Management Software (VMS) and Web Client software.

Mobile Application Security testing of Trinity Mobile Application (Android and iOS) and India Post Mobile Application (Android and iOS).

Common Criteria Certification Product Evaluation for M/s Nivetti Systems-EAL4 , M/s Gajshield EAL4 and M/s AnexGate-EAL2 under progress.

The Testing/Audit of L1 registered device for M/s Linkwell is completed and assessment of L0 devices for M/s Bio enable is completed.

Comprehensive Security (CSA) Audit of Critical Government Applications namely Kisan Credit Card Scheme, National Consumer Helpline Portal and mSewa Appstore.

Third Party Audit for National Tuberculosis Institute (NTI) , Bangalore, Government of India.

ISMS Audit of CAMS , Central Bank of India , UIDAI and BHEL .

Surveillance assessment of Cloud Service Provider (CSP Audit) carried out for M/s. TCL, M/s Nxtgen and further audit is planned for M/s NTT Global Data Centre.

Website Quality evaluation under progress for, ICAR-National Bureau of Agricultural Insects, ICAR-Nivedi, Bureau of Indian Standards, Postal Training Centre Mysuru.

## ii) Safety Testing

Safety laboratory of ETDC Bangalore testing services are accredited as per ISO/ IEC 17025: 2017 standard.

The Safety laboratory of ETDC Bangalore has obtained BIS recognition for testing of 27 types Electronic and IT products, Household Products and Audio video products for Safety compliance under CRS scheme.

Facility Upgradation: Safety Lab ETDC, Bangalore has augmented 4 Test Facilities including Impulse Generator/Tester, Glow wire Test apparatus, Flammability Tester.

Laboratory has supported the Industry by carrying out large volume of CRS testing jobs during the initial phase of introduction of CRS scheme, by Government of India. As many as 400 jobs are executed, certifying 27 products and thus helping about 180 no. of manufacturer's / suppliers to get registered under the scheme.

## iii) Electro-Technical Testing Services

- **EMI/EMC Test lab.**

Medical equipment : Number of critical and life-supporting medical devices, such as Teller Care Nurse Call System, M1-Leg, Kangaroo infant warmer, Rhythem ECG, Vein locating instrument, Emergency Respiratory Ventilation Apparatus, Surgical System, ICU ventilator, Jacket Warmer and Nano Aerpod, etc.

Industrial and Automotive Equipment: industrial equipment such as a String Monitoring Box, an Electric Wheel Chair, Hipase-E-Large, an Intellipod, an Electronic Vehicle charger with simulator, a network PTZ camera, a network IP camera, are tested for the industries. Electrical panel used in the power distribution system for the BHEL, Nuclear Power Corporation and KPTCL etc tested as per the industrial requirements.

Railway Equipment: Many railway equipment such as KAVACH, Loco TCAS (LTCAS), Alarm Annunciator, Break Interface Unit, Vehicle Control Unit, IoT Based Water Level Indicator System, Single Section Digital Axle Counter were tested as railway requirements.

IT related equipment : Biometric Device, were tested as per FCC Part 15 B, IoT Devices, Point of Sale Terminal, Access Control Product, All in One PC, Intelligent Modem 4G, 8 port Switch, XIO-AMR-MODEM, and Data Concentrator Unit and smart energy meters were tested as per the IT standards.

- **Electric Wheelchair:**

Tetra Exi from Ostrich Mobility is a sleek and smart powered wheelchair designed for enhanced mobility. With its revolutionary Split Frame Chassis (SFC), It offers excellent manoeuvrability, stability, and comfort. The wheelchair features a range of convenient and safety-oriented elements such as urine bag holder, manual seat height adjustment, call and fault alarms, seat folding for transportation, and a maximum loading capacity of 130 Kg.

- **M-1 LEG (Bionic Prothesis):**

The device is designed for patients with prosthetics, with the goal of improving their quality of life.

## iv) Calibration Services :

Automated Calibration of Multifunction Calibrator ( make FLUKE 5550 and 5560).

In NABL Scope of Calibration added Pulse Count as a new Electrotechnical Parameter.

Enhanced NABL scope for AC Voltage measurement from 1 MHz to 1 GHz.

#### 9.7.4.7 ETDC, Chennai

##### i) IT Services

- **CCTV Camera Testing:**

ETDC Chennai has received 3 Network cameras under PPO and 2 Network cameras under CRO schemes for performing third-party security assessment as per the “Essential Requirement(s) for Security of CCTV guidelines - 2024”.

- **Vulnerability Assessment:**

ETDC Chennai has conducted Vulnerability Assessment of Video Surveillance Network implemented by KRCL (Konkan Railway Corporation Ltd) in the Jurisdiction of USBRL (Udhampur-Srinagar- Baramulla-Rail Link) Project at Reasi, Bakkal, Dugga, Sawalkote, Sangaldan and Sumber. Railway Stations

##### ii) Electro Technical Testing

Smart Breather tested as per IS9000-8

Medical equipment tested for EMI-EMC compliance as per IEC61000-4 series of standards.

300 kVA UPS Testing carried out at M/s.EATON, Puducherry as per IEC62040-3 for dynamic parameters. ETDC, Chennai is having capacity to undertake measurement of 700Kva

##### iii) Centre for Reliability

The Centre for Reliability (CFR), a premier organization of the Government of India under the STQC Directorate, continues to specialize in the reliability assessment of Indian electronics, electro-mechanical, and IT products.

Under the Electronics Policy of the Government of India and the IoT Scheme of STQC, CFR undertook a reliability-prediction programme covering IoT cameras, Network Video Recorders, and other electronic equipment. These assessments were carried out in accordance with internationally recognized standards—MIL-STD-217F Notice 2 and Telcordia SR-332 Issue 4—to ensure rigorous evaluation and enhanced product dependability.

#### 9.7.4.8 ETDC, Hyderabad

##### i) IT Services

ETDC Hyderabad has successfully completed the first Toll Management System (TMS) certification. As part of this assessment, activities such as Functional Testing, Security Testing, Source Code Review, Database tamper-proof/ Integrity testing etc. were carried out.

Officers from ETDC Hyderabad were involved in the witness testing of Drone Security Testing at ETDC Bengaluru as per the Army Design Bureau (ADB) requirements and provided their inputs.

CCTV assessment was carried out under both CRO and PPO categories as per the as per the Gazette Notification by MeitY dated March 6, 2024.

As part of eProcurement Assessment, Functionality Testing, Security requirements as per OWASP guidelines, Requirements related to GFR 2017, IT Act, CVC Guidelines.

Application security assessment was done for VMS application security assessment, SD AI NVR.

Functionality testing was performed as per requirements specified in the RFP/SRS.

GIGW Testing was performed as per the Govt of India guidelines specified in 3.0.

##### i. JNARDDC Website

- ii. ALIMCO Website
- iii. BDL Website

Following products has been tested at ETDC Hyderabad for Electronics products:

- EVMs, VVPATs and accessories produced by ECIL Hyderabad.
- Defence products such as Muzzle Bore sights, Hydraulic Servo Actuators, Lithium Batteries, Rugged Servers and systems etc
- Rail Testers, Weld Testers, Telecommand units etc. for environmental parameters
- Street Light Controllers
- Fire Alarm Control Panels and CCMS Units
- ZED Blox ACTIPOD Vaccine Carrier, Subzero vaccine refrigerator and Raksha auto Dipper with RBA Sensor, Rotary Electronic-Actuator
- Multi-load Controller, VHF FM Transceiver, EV Chargers, Tele-command Receiver, BEL Power Supplies, Excitation Panel for 120KW Alternator, CBS Antennas, Tele-command encoder/ decoder, Ethernet Switch, Launch Controller, Electronic Security Systems etc.

#### 9.7.4.9 ETDC, Pune

##### i) IT Services

CCTV Device Security Assessment as per ER 01:2024 under the IoT System Certification Scheme (IoTSCS). The key objective is that the CCTV Cameras shall comply with the requirements as specified in the Essential Requirements mentioned in Gazette Notification issued by MeitY. Testing was carried out for CCTV devices under both CRO and PPO certification schemes.

Functional Testing of Toll Management System Applications for Kent Intelligent Transportation Systems (India) Pvt. Ltd. and Metro Infrasy Pvt. Ltd. The software comprises of different modules such as Toll Collection Module, System Configuration Module, Static Weight Bridge Module, etc.

Website Quality Evaluation as well as Surveillance Audit: The centre has evaluated websites for various departments for e.g., Telecom Regulatory Authority of India (TRAI), Munitions India, etc. as per GIGW 3.0. Surveillance audit carried out for seven (07) certified websites such as UIDAI, Department of Social Justice and Empowerment, Department of official language, etc.

Security Testing / Audit of Web applications/ Micro services namely Chatbot Solutions, Reports & MIS\_BI Module, Transmission Module and DNK & Customs Portal was completed of IT 2.0 developed by Centre of Excellence in Postal Technology (CEPT), Department of Post, Govt. of India as per latest OWASP Top 10 security risks.

Performance Testing of Web applications/ Micro services namely Chatbot Solutions, Reports & MIS\_BI Module, Transmission Module and DNK & Customs Portal was completed of IT 2.0 developed by Centre of Excellence in Postal Technology (CEPT), Department of Post, Govt. of India, for identifying performance metrics (concurrent users and hits per second data).

Comprehensive Security Audit (CSA): The centre has conducted the Comprehensive Security Audit(CSA) for consumer centric website/applications such as Digilocker, PM-KISAN Portal.

Awareness session was conducted on “Cyber Hygiene and Security” as a part of preventive vigilance activity in ETDC Pune under capacity building program.

## ii) Electro Technical Testing

### Testing Activities:

Obtained NABL accreditation as per ISO/IEC 17025:2017.

Onsite testing of VVPAT batteries done for Election Commission of India.

Highlights: Following items were tested:

- Traffic Light Signal
- Automatic Vehicle Classifier
- Hybrid Lane Controller
- Overhead Lane controller
- SMPS/Battery Charger.
- Under make in India Patented (in India) Product Induction based Laundry Iron manufactured by Redicitus Technologies Pvt. Ltd.

Calibration of VVPAT battery testers for Election Commission of India.

Calibration services given to government organization like Indian railways, DRDO Laboratories & many other private organizations.

In-house repair done for Multifunction calibrator & High voltage probe.

Inter laboratory comparison and proficiency testing programs are executed successfully as per plan.

Automated DC energy meter calibration done as per customer's requirement.

### 9.7.4.10 ETDC, Mohali

Successfully renewed National Accreditation Board for Testing and Calibration Laboratories (NABL) Accreditation for our:

- Calibration Laboratory in fields of Electro-Technical, Mass, Dimension, Pressure, temperature and Speed Calibration, and valid till Apr 2029
- Testing Laboratory in fields of Electrical and Electronics Testing, and valid till March 2029

Successfully renewed Conformity Assessment Body (CAB) designation from Telecommunication Engineering Centre, Ministry of Communications for testing of Telecommunication devices, and valid till Apr 2028.

Testing of CCTV cameras in line with ER: 01 security requirements is being carried out.

E-Procurement System (EPS) Conformity Assessment is being carried out for EPS portals various Government departments.

Biometric Device Testing as per ISO standards and UIDAI guidelines is conducted for Fingerprint and Iris (Authentication and Enrolment) devices.

Performed testing of VVPAT and Ballot Units, in collaboration with Election Commission of India (ECI) and Bharat Electronics Limited (BEL).

Successfully participated and received certificate for satisfactory work done in Hindi language in Office, at Rajbhasha Hindi Parliamentary Committee Review conducted at Shimla, Himachal Pradesh.

Continuous support to Govt. and Private industries and IT companies in North region including states of Punjab, Haryana, Himachal Pradesh and Jammu & Kashmir, by providing Testing and Calibration services, broadly in the areas of Electrical and Electronics Devices Testing, Environmental Testing, Biometric Devices Testing and Software Testing.

#### 9.7.4.11 ETDC Jaipur

Comprehensive Cyber Security Audit carried out for critical database applications of NIC:

- UMANG Platform – ensuring security of citizen-centric service delivery across ministries.
- Jal Jeevan Mission Portal – safeguarding sensitive infrastructure and water resource data.
- API Setu Portal – reviewing API integration layer security for government services and ensuring secure data exchange.

Web Application Security Testing

Associated in Security Testing of Passport Seva Project 2.0 Applications.

Conducted vulnerability assessment and penetration testing of upgraded modules.

Focus on secure authentication, citizen data confidentiality, and resilient service delivery.

Supported digital governance initiatives by ensuring secure, reliable, and citizen-centric online services.

Electronics Test & Development Centre (ETDC) has reaffirmed its role as a premier testing laboratory for surveillance and security products. ETDC actively supported national initiatives by conducting compliance testing of Closed-Circuit Television (CCTV) systems under mandated Government schemes, thereby ensuring quality, security, and reliability of products in this critical sector.

#### 9.7.4.12 ETDC, Goa

Calibration, Testing and Quality Assurance Training services are being provided by ETDC Goa. This Laboratory is accredited by NABL as per ISO/IEC: 17025:2017 for Electro-Technical, Mechanical & Pressure parameters calibration. Calibration, Testing and Training services are being provided by this laboratory to the different Govt. and private organizations, industries & institutions located mainly in the state of Goa and adjoining districts in the states of Karnataka and Maharashtra. During year 2025, following Testing, Calibration and Training services are provided by ETDC Goa – Calibration services are provided to the 47 organizations. Total 124 calibration jobs are completed.

Under Website Certification Scheme, following Government websites were tested as per GIGW 3.0 for certification-

- Website of Dept. of Higher Education, Govt. of Goa
- Website of Indian Coast Guard
- Conducted and completed security testing of following web applications for OWASP top 10 security Risks (2021).
- Official Website of Directorate of Fire & Emergency Services
- Conducted and completed Smart City evaluation (VA/PT, EPS, TEVCCS and process audit) of Panaji and Sholapur.

#### 9.7.4.13 ETDC Ajmer

Completed security assessment & Evaluation of network cameras as per CCTV-ER scheme

E-Procurement System Certification: Completed Testing, Evaluation and certification of Global E Auction.

ETDC Ajmer has played a pivotal role as a nodal office for the Smart City Audit.

The following Activities are to be considered in the Smart City Audit:

- End Point Devices Security Audit
- Vulnerability Assessment of Network Infrastructure
- Process Audit
- Trusted Electronics Value chain audit

#### 9.7.4.14 ETDC, Solan

Website Quality Certification (WQC)

Multiple Government Websites were tested for Compliance with GIGW 3.0 & GIGW 2.0.

Web Application Security Testing

Application security testing was conducted for multiple clients ensuring OWASP compliance.

Vulnerability Assessment & Penetration Testing (VAPT)

Multiple infrastructures, including physical and virtual systems, were evaluated to detect and help remediate security gaps.

Cyber Security Testing of Smart Cities

Cyber Security Audit of Shimla Smart City Carried out assessing and certifying various electronic and IT systems, including devices, software, and infrastructure, to ensure security, quality, and compliance with national and international standards.

e Procurement System Certification (EPS)

ePS of CPWD is under testing for Functional, VA-PT, Application Security and Performance Testing.

#### IoT System Certification Scheme (IoTSCS)

Multiple CCTV cameras are under testing to verify the compliance of claims made by CCTV developer/manufacturer regarding Hardware and Software Cyber Security with respect to Essential Requirements (ER:01 2024) mentioned in Gazette Notification dated 6 March, 2024 issued by MeitY.

#### New Initiatives

Started ePS and CCTV certification for the first time at STQC IT Center, Solan

#### Major Achievements

National-Level Audits & Assessments of Smart Cities

Comprehensive audit conducted for smart city Shimla infrastructure encompassing IoT, surveillance, traffic management, and centralized command centres.

On-site Calibration of instrument/ equipment is successfully completed for CSIR-IHBT, Palampur, Himachal Pradesh during 18 August to 21 August 2025 with ETDC Mohali

#### 9.7.5 Capacity Building

STQC is conducting various Capacity building & skill development programs through regular/ short term training courses, workshops etc. ETDC Jaipur/IIQM, CFR Chennai, ETDC Goa & ETDC Solan are dedicated centres for training and

have conducted many training courses on Quality Management Reliability, Lab Management, Information Security etc.

STQC has conducted following courses in 2025

### **IIQM Jaipur**

Indian Institute of Quality Management (IIQM), Jaipur, under STQC Directorate, Ministry of Electronics & IT, has conducted extensive training programs in 2025 to enhance capabilities in Information Security, Quality Management, and Laboratory Management systems. These trainings contribute significantly to building skilled professionals aligned with national and international standards

1. Delivered comprehensive training for nearly 40 courses across multiple key organizations.
2. Enabled enhanced auditing and management system competencies across security, quality, and laboratory domains.
3. Supported national initiatives to strengthen organizational capabilities and compliance with international standards.

#### **I. ISMS Lead Auditor (ISMS-LA) Training**

- Number of Courses: 15
- Focus: ISO/IEC 27001:2022 Lead Auditor certification.
- Enhancing skills for auditing Information Security Management Systems (ISMS).
- Key beneficiary: Government and corporate technical teams.
- Here is the list of organizations for ISMS-LA training courses:
- ETDC Goa
- NADP Nagpur
- IOCL
- Central Bank of India
- UTI Infrastructure
- ETDC Solan
- PGCIL Manesar

#### **II. Quality Management System Lead Auditor (LA-QMS) Training**

- Number of Courses: 4
- Aligned with ISO 9001:2015 standards for Quality Management Systems auditing.

#### **III. Laboratory Quality Management System (LAB-QMS 17025) Training**

- Eight Specialized training on ISO/IEC 17025:2017 and NABL requirements.
- Coverage includes diverse organizations such as Borosil, Ceptam, ICMR, DRDO, and ISRO.
- Strengthening laboratory testing and calibration quality assurance.

#### **IV. Cybersecurity Auditor Training**

- Certified Information Systems Security Auditor (CIISA): 2 courses at IIQM Jaipur participants.
- Certified Information Security Professional (CISP): 2 courses conducted at IIQM Jaipur.
- Enhancing professional competence in security audits and risk management.

## V. Other Specialized Courses

- CIQA (Information Quality Auditing) course.
- ISMS Transition cum Awareness programs.
- Measurement Uncertainty in electrotechnical parameters.

## Key Achievements and Impact

- Trained over 40 specialized courses in information security, quality, and laboratory management system fields.
- Developed a skilled talent pool capable of conducting audits compliant with international standards.
- Contributed to capacity building in central government organizations and industries, supporting national quality initiatives.
- Held NBQP recognition for key courses reflecting adherence to national quality frameworks.

Facilitated the adoption of the latest ISO standards, especially ISO/IEC 27001:2022, ISO/IEC 17025:2017.

## B) ERTL(N), New Delhi

### Training and Capacity Building

- Conducted Training Program on GIGW 3.0 for NRSC, ISRO, Hyderabad.
- Focused on the latest Guidelines for Indian Government Websites (GIGW) 3.0 standards.
- Covered topics of accessibility, usability, cybersecurity, and compliance for mission-critical web portals.

Interactive sessions with technical teams of ISRO for adoption in space research-related citizen web application ISO 9001:2015.

## C) ETDC Solan

Training on ISMS LA Course as per ISO/IEC 27001:2022 is successfully organized for Officers of Baroda Apex Academy (Bank of Baroda) and internal candidates from STQC HQ and other STQC Labs during 17 March to 21 March 2025 at ETDC Solan.

On-site ISMS LA Course as per ISO/IEC 27001:2022 is successfully organized for Officers of STQC HQ and other STQC Labs during 28 April to 02 May 2025 at STQC HQ, New Delhi.

On-site QMS LA Course as per ISO 9001: 2015 is successfully organized for Officers of STQC HQ during 02 June to 06 June 2025 at STQC HQ, New Delhi

Conducted following training programs for capacity enhancement through design, development and conduct of training for the working professionals to develop their skills in different areas-

- Lead Auditor training course for ISMS (ISO 27001:2022) (5 days)
- STQC-CISP - Information Certified Security Professional Course (5 days)
- Laboratory Management System & Internal Audit as per ISO/IEC 17025:2017 (4 days)
- Calibration System (2 days) and measurement Uncertainty (1 day)

Training programs are attended by 135 participants from 32 organizations.

Training programs are attended by 76 participants from 25 organizations.

### 9.7.6 Activity in North East Region

ETDC Guwahati & Agartala are two laboratories under the STQC Directorate, MeitY, Govt. of India operating in the NE Region. and extending services to 08(eight) states of the region

#### 9.7.6.1 ETDC, Guwahati

ETDC, Guwahati is one of the laboratories under the STQC Directorate of Ministry of Electronics & Information Technology, Govt. of India operating in the NE Region and extending the following services to 08(eight) states of the region:

- Test & Calibration services to the Industries, Technology users & Service providers.
- Website Quality certification for different websites of Govt. Ministries, Department and PSUs etc.
- Smart City Audit
- CCTV evaluation for compliance of Essential Requirements–01 (ER-01).
- Application Security Testing
- Performance Testing
- e-Procurement System (EPS) Testing

#### I. Initiatives in Test & Calibration services:

Test & Calibration services of ETDC Guwahati is extended to the organizations located throughout the NE Region covering all the 8(eight)-States towards improvement of Quality of their products and services. The services are received by most of the Small, Medium and Large Scale Industries covering the Industrial sectors like – Oil & Natural Gas, Oil Refineries, Exploration units, Railways, Indian Air Force(IAF), Power - Generation, Transmission & Distribution, Paper, Cement & Building material, Food & Beverages, Cosmetics, Cable & Conductors, Fertilizer, Plywood, Carbon Products, Steel, and Service sectors like – Aviation, Engineering & Construction, Telecommunication, Automobile, Service & Maintenance units, R&D and Test Labs, Hospitals, Pharmaceutical & Pathological Laboratories etc. About 2100 calibration jobs being executed by ETDC Guwahati – covering more than 60 Nos. of LSI, MSI, SSI Industrial units, Govt. PSUs, Private and other technology user organizations of NE-Region.

#### II. On-Site Calibration Camps:

To make the STQC services available at the door steps of the client's' site located at various remote places in the NE Region, on-site calibration camp being organized by ETDC Guwahati at Oil India Ltd., NEEPCO, BCPL, GAIL, AGCL, BVFCL, AAI to facilitate the qualitative requirements of the industries and technology users.

#### III. NABL Accreditation:

Calibration services of ETDC, Guwahati are accredited (No. CC-3797) by the National Accreditation Board for Testing and Calibration Laboratories (NABL) in conformance to ISO/IEC 17025, 2017 international standard for accreditation in the fields of Electro-Technical (AC/DC Current, Voltage, Power, Energy, Frequency, Resistance, Inductance & Capacitance), Thermal (Temperature), Mechanical (Pressure, Mass, Balance, Dimension & Volume) calibration services.

Initiatives in IT and e-Governance Test & Assessment Services by ETDC Guwahati:

#### IV. Website Quality Certification:

In line with GIGW 3.0 requirements under the STQC Website Quality Certification (CQW) scheme, ETDC Guwahati is testing, evaluating, and assessing more than 18 websites belonging to various Directorates and Ministries for certification.

**Smart City Audit Project:**

As per ISMS guidelines, ETDC Guwahati has actively contributed to the Smart City Audit Project, successfully auditing 07 Smart Cities across the country.

**V. IoT SCS (CCTV Evaluation):**

The centre is currently evaluating 25 CCTV applications, including 56 different camera models, for compliance with Essential Requirements–01 (ER-01).

**VI. Application Security Testing:**

ETDC Guwahati has successfully carried out Application Security Testing of 07 web applications of the Department of Posts and other Central and State Government organizations.

**VII. Performance Testing:**

The centre has conducted performance testing of web applications with 2000 concurrent users, ensuring robustness and scalability.

e-Procurement System (EPS) Testing:

With the support of ERTL (E), Kolkata, ETDC Guwahati is also engaged in e-Procurement System (EPS) testing, covering:

- Functional Testing
- Web Application Security Assessment
- Compliance Verification (GFR / CVC / IT Act / IT Process Security)
- Vulnerability Assessment & Penetration Testing
- Performance Testing

**VIII. Recognition:**

ETDC Guwahati, along with a few other STQC centres, received an appreciation letter from the Secretary, Department of Posts, Government of India for completing the Security and Performance Testing of DoP IT 2.0 Advanced Postal Technology (APT) Applications within a record time of one month.

**9.7.6.2 ETDC, Agartala**

This lab undertook the significant task of conducting vulnerability assessments and performance testing across various modules of the India Post web application, ensuring that the core principles of information security — confidentiality, integrity, and availability — are upheld.

Explored and successfully implemented a new area of auditing focused on the secure utilization of Aadhaar data through the Aadhaar Data Vault and associated web services, ensuring compliance with UIDAI guidelines and the required control measures.

Website evaluation /certification job as per GIGW 3.0 with W3C recommended open-source tools

Physical and Configuration verification of several PC, peripheral and UPS for different Govt. organization.

Applications are audited as per following OWASP Application Security Verification Standard 4.0 and the OWASP Top 10 – 2021 checklist.

Second phase audit for Smart City Agartala, Tripura and 03 smart cities for first phase audit.

This year we have started this specified works. Some of the clients are I-Torzine, Kolkata , Prime infoserv LLP, KELTRON etc.

Assessment of Aadhaar data stored in ADV and associated web services in compliance with UIDAI checklist.

## 9.8 National Institute of Electronics and Information Technology (NIELIT)

### 9.8.1 Introduction

The NIELIT Digital University (NDU) Platform has been launched by NIELIT under the Ministry of Electronics and Information Technology (MeitY) to deliver online and blended skill- based courses in emerging technology areas. This Platform is designed to offer future-ready, industry-aligned programs in emerging technologies such as Artificial Intelligence, Cybersecurity, Cloud Computing, and other frontier domains. This platform also features built-in virtual labs for real-time experimentation in Semiconductor Design, cybersecurity, Cyber Forensics, Industry 4.0, and other emerging domains. Through the NDU platform, every learner can have access anytime-anywhere to NSQF-aligned courses, the credits of which will be transferred to the Academic Bank of Credits upon successful completion

The National Institute of Electronics and Information Technology (NIELIT) is an autonomous scientific society under the administrative control of Ministry of Electronics and Information Technology (MeitY), Government of India. NIELIT is actively engaged in Capacity Building and Skill Development in the areas of IECT such as Future Skills, Cyber Law; Cyber Security; Cloud Computing; ESDM and related verticals. It offers courses in Degree/ Diploma Levels as well as Skilling Courses and is also one of the National Examination & Accreditation Bodies which accredits institutes/ organizations for the conduct of courses in the Non-Formal Sector. NIELIT is also rolling out Digital Competency Programmes for many State Governments for its employees and the masses. NIELIT is recognized by NCVET as an Awarding Body and Assessment Agency for NSQF aligned courses.

NIELIT has its presence at fifty six (56) locations at Agartala, Aizawl, Ajmer, Aurangabad, Balasore, Bhubaneswar, Bikaner, Buxar, Calicut, Chandigarh, Chennai, Chitradurga, Chuchuyimlang, Churachandpur, Daman, Delhi, East Delhi, South West Delhi, Dibrugarh, Dimapur, Gangtok, Gorakhpur, Guwahati, Haridwar, Hyderabad, Imphal, Itanagar, Jammu, Jorhat, Kargil, Kohima, Kolkata, Kokrajhar, Kurukshetra, Leh, Lucknow, Lunglei, Majuli, Mandi, Muzaffarpur, Noida, Pasighat, Patna, Pali, Pilibhit, Ranchi, Ropar, Senapati, Shillong, Shimla, Silchar, Srinagar, Tezpur, Tezu, Tirupati, and Tura. Its headquarters is located in New Delhi.



Besides the own Centres, NIELIT is also well networked through about 750+ Accredited Training Institutions for training of O/A/B/C level courses and through a network of about 8500+ Facilitation Centres engaged in training of Digital Competency Courses making NIELIT distinctly positioned in terms of its outreach to all corners of the country and all segments of the society.

### Spectrum of NIELIT Courses

NIELIT plays an important role in skilling of the youth in the area of IECT. The wide repertoire of NIELIT Courses includes: (i) Degree/Diploma Level Courses such as B.Tech, M.Tech, BCA, MCA, and PhD programmes offered by the NIELIT Deemed to be University in the area of IT and Electronics (ii) Skilling Courses (Long Term) such as O Level(IT), A Level (IT), CHMT-O Level, etc. ; (iii) Skilling Courses (Short Term) in niche areas such as IoT, Cloud Computing, Machine Learning, Cyber Security, AI, etc. and (iv) Digital Competency Programmes for the proliferation of Digital Proficiency in the country; besides specialized programmes in emerging technologies targeted towards empowering the employees of the State Governments and Departments of Central Line Ministries. In addition, NIELIT has also created

expertise for the rollout of customized skilling, upskilling, and reskilling programmes as per the specific needs of youths and industries.

NIELIT qualifications are widely accepted across the country. Owing to the quality, some of the NIELIT digital competency courses are linked with both promotion & recruitment by number of state governments viz; Arunachal Pradesh, Bihar, Chandigarh, Daman & Diu, Gujarat, Rajasthan, Sikkim, Uttar Pradesh. Also, NIELIT is offering its CCC course free of cost in online mode as a knowledge product through its virtual academy. The course is also available at 15+ Indian and International Language, accessible at <https://nva.nielit.gov.in/ccc>

Since the year 2014, NIELIT has trained over 95 lakh candidates. Taking into the account advancement in IT and Electronics and emergence of disruptive technologies, NIELIT has been continuously upgrading its courses in emerging technologies such as Artificial Intelligence, IoT, Big Data, Cloud Computing, Robotics, 3D Printing, Chip Design, Embedded Technologies, VLSI and related technologies. NIELIT is amongst the front-runners that have aligned 139 Skill Oriented courses with National Skills Qualifications Framework (NSQF) at different levels ranging from Level 2 to 6.

NIELIT Centres at Aurangabad, Calicut, Kolkata have been identified as Technology Resource Centres to offer blended learning programmes under the Future Skills prime initiative which is being jointly conceived by MeitY and NASSCOM. The first IndiaAI Lab has been established at NIELIT Delhi and since then, 27 IndiaAI Labs have been established at NIELIT Centres. NIELIT plays a pivotal role in building a highly skilled semiconductor workforce through Specialized training programs & certifications in semiconductor design, fabrication, and packaging and establishing Centre of Excellences in Chip Design and related technologies. NIELIT has also expertise in cyber skilling at various levels.

#### **NIELIT Deemed to be University:**

NIELIT achieved a significant milestone by being conferred the status of Deemed to be University (under distinct category) vide Gazette Notification No. 9-3/2023-U.3(A) dated 15 July 2024, published in Part-I, Section-1 of the Gazette of India with NIELIT Ropar (Punjab) as its main campus along-with 11 constituent units located at Aizawl, Agartala, Aurangabad, Calicut, Gorakhpur, Imphal, Kohima, Patna, Srinagar, Ajmer (Kekri) and Itanagar. This recognition marks a major leap forward in the nation's journey toward digital empowerment and inclusive education. Recognized under the UGC's "distinct" category, the NIELIT Deemed to be University is the only university under MeitY, offering industry-relevant undergraduate, postgraduate, doctoral, and diploma programs in IT and Electronics. The University focuses on Research, Innovation, and Entrepreneurship, Faculty and Staff Development programmes, and enhancing the infrastructure. NIELIT Deemed to be University was inaugurated on 03.01.2025 at 12 locations and the inaugural event was jointly presided over by Shri Lakshman Prasad Acharya, Hon'ble Governor of Assam, Shri Ashwini Vaishnaw, Union Minister of Railways, Information & Broadcasting, and Electronics & Information Technology, and Dr. Himanta Biswa Sarma, Chief Minister of Assam, during a ceremony held in Guwahati.



### Launch of NIELIT Digital University (NDU) Platform:

The NIELIT Digital University Platform has been launched on 2nd October 2025, which marks a historic milestone in India's digital transformation journey. It represents a first-of-its-kind model of a digital university that is affordable, inclusive, and globally relevant, aligning with the vision of a Viksit Bharat@2047. NDU Platform is designed to offer future-ready, industry-aligned programs in emerging technologies such as Artificial Intelligence, Cybersecurity, Cloud Computing, and other frontier domains. By leveraging NDU Platforms, learners across India can access high-quality, affordable programs that enhance their employability and equip them for emerging job markets.

### 9.8.2 NIELIT Centres/Labs/Infrastructures Launched/inaugurated

#### (i) NIELIT in strengthening India-Fiji Collaboration in Skilling and Capacity Building

On 25<sup>th</sup> August, 2025, in the august presence of Hon'ble Prime Minister of India, Shri Narendra Modi, and Hon'ble Prime Minister Sitiveni Rabuka, an MoU was exchanged between the NIELIT and Pacific Polytech, Fiji. This landmark MoU marks a significant step in advancing cooperation in the areas of human capacity building, skilling, and upskilling. Under this partnership, NIELIT will establish its first foreign centre in Fiji, creating new avenues for global outreach and collaboration. This partnership not only strengthens India-Fiji bilateral relations but also paves the way for global knowledge exchange and building a future-ready workforce.

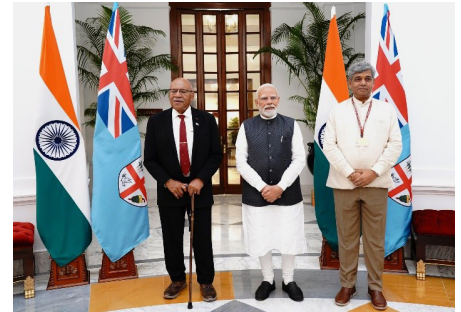

#### (ii) Inauguration of Atal Bihari Vajpayee NIELIT Extension Centre, Pilibhit

Aiming towards expansion of strengthening digital skilling infrastructure and enhancing outreach in the region, NIELIT has established a new Centre at Pilibhit, Uttar Pradesh, increasing the total number of its own Centres in the state to four. Hon'ble Minister of State for Electronics and Information Technology & Commerce and Industry, Shri Jitin Prasada, inaugurated the Centre, namely, Atal Bihari Vajpayee NIELIT Extension Centre in Pilibhit on 23rd December, 2024. During the occasion, the Hon'ble Minister also interacted with students of NIELIT Pilibhit. Further, a conclave titled «Technology and Skill Development Conclave» was conducted at the centre in Pilibhit on December 21, 2025 which was attended by the Hon'ble Minister. During his visit, Hon'ble MoS inaugurated a new state-of-the-art Internet of Things (IoT) Laboratory at the centre, designed to provide practical, industry-oriented training to local students.



### (iii) NIELIT is set to establish permanent campus at Guwahati

On 25th February 2025, during the Advantage Assam 2.0 event, Hon'ble Chief Minister of Assam, Dr. Himanta Biswa Sarma, formally handed over the land for NIELIT permanent campus at Guwahati (under NIELIT deemed to be University). The land, located at Jagiroad near the upcoming TATA Semiconductor facility, marks a major milestone in advancing digital education and skill development in the region. The ceremony was graced by the presence of Hon'ble Union Minister Shri Ashwini Vaishnaw, Dr. Ranoj Pegu, Hon'ble Education Minister of Assam, and witnessed by over 1000 delegates from industry, academia, and government.

### (iv) Inauguration of NIELIT Centre of Excellence in Chip Design, Noida

In a significant step toward advancing capabilities in semiconductor design and development, NIELIT's Centre of Excellence (CoE) in Chip Design was inaugurated by Shri S. Krishnan, Secretary, MeitY, at Noida in association with SoCTeamup Semiconductors Pvt Ltd, a DPIIT-recognized startup. The new Centre of Excellence is poised to address the growing demand for skilled professionals in the semiconductor and chip design industries by offering state-of-the-art facilities for research, innovation, and training in VLSI and Chip Design.



### (v) National Conference on Cyber Crime, Digital Forensics and Intelligence

NIELIT has successfully organized a Two-Day National Conference on Cyber Crime, digital Forensics and Intelligence under the theme "*Cyber Secure Bharat: Fortifying India's Digital Future*" from 25<sup>th</sup> to 26<sup>th</sup> July 2024 at Kohima, Nagaland. The conference was graced Shri S. Krishnan, IAS, Secretary, MeitY was the Guest of Honour besides other dignitaries. The conference brought together experts, practitioners and scholars from across the Northeast region and the rest of India, making it a significant platform for dialogue on emerging challenges and advancements in the field of Cybercrime digital forensics and intelligence.

### (vi) NIELIT's 3rd International (NICE-DT 2025)

NIELIT has successfully organized its 3<sup>rd</sup> NIELIT International Conference (NICEDT-2025) on Communication, Electronics, and Digital Technologies, which was held at NIELIT Ropar on 14th and 15th February 2025. The conference, which spanned two days, brought together a diverse group of researchers, academicians, industry professionals, and students from across the globe to foster knowledge exchange and collaboration in cutting-edge Information, Electronics, and Communication Technology (IECT) fields. The conference emphasized the importance of digital innovation, sustainable technology, and interdisciplinary collaboration in shaping the future of IECT.

### (vii) Inauguration of High-End Labs under the Chip to Startup Programme

On 4<sup>th</sup> January 2025, Shri. S Krishnan, IAS, Secretary, MeitY inaugurated Digital India RISC-V Embedded System Design Lab and Digital India RISC-V Soc Design Lab under Chip to Startup Programme of MeitY at NIELIT Aurangabad

in the presence of Smt. Sunita Verma, Scientist G and Group Co-ordinator, MeitY, and other senior Officers from NIELIT.

#### (viii) Inauguration of IT cum Security Lab

On 20th November 2024, Ms. Tulika Pandey, Sr. Director & Group Coordinator, HRD Division, MeitY, Govt. of India, inaugurated the IT and Security Lab under the project “Empowering Police and Government Officials of NE States through IT and Cybersecurity Training” at NIELIT Shillong, in the presence of other dignitaries.

#### (ix) Establishment of Remote Hardware Lab

NIELIT Chennai has established a state-of-the-art Remote Hardware Lab (RHL) as part of its Virtual Lab initiative. This innovative facility provides students with remote access to advanced FPGA platforms (including Ultrascale+ boards, supported by the Department of Biotechnology, Government of India) and IC design tools of Synopsys and Cadence (supported under the Chips to Startup (C2S) program of MeitY, Govt. of India).

#### (x) 1st IEEE Uttar Pradesh Women in Engineering Conference (UPWIECON-2025)

In its endeavour to promote women’s participation in today’s technology-driven world, NIELIT has organized the “1st IEEE Uttar Pradesh Women in Engineering Conference (UPWIECON-2025)” on October 30-31, 2025, under the banner of the IEEE UP Section & @WIE IEEE UP Section affinity group in Dehradun. The conference was inaugurated by Hon’ble Uttarakhand Cabinet Minister, Shri Ganesh Joshi and it aimed to promote women in Engineering and served as a global platform for women technologists, researchers, and academicians to exchange ideas and foster collaboration in Electrical, Electronics, and Computer Engineering.

#### (xi) Union Finance Minister launched Project ‘SAMARTH’ at NIELIT Kohima

Hon’ble Union Finance Minister, Smt. Nirmala Sitharaman launched Project ‘SAMARTH’ at NIELIT Kohima, a groundbreaking initiative for school students across the Northeast to build skills in AI, Robotics and Digital Hardware towards empowering young minds for a tech-driven future. In the presence of Union Finance Minister, NIELIT Kohima also signed an MoU with Tata Electronics to strengthen India’s semiconductor skilling ecosystem and bridge the skill gap in the semiconductor industry. A significant step toward building future-ready talent.



### 9.8.3 Capacity Building Projects:

#### 9.8.3.1 Initiative for Cyber Security Aware Society in NE States

Project is sponsored by MeitY vide Administrative Approval No. AAA.22/2/2022-CSR-DoA dated 22/02/2022 with financial support of Rs. 725.19 Lakh over a period of three (03) Years. Under the project, a total of 288 workshops to be conducted in NE states, out of which 305 workshops have been conducted.

#### 9.8.3.2 Design and Development of EEG Based Real-Time Depth of Anaesthesia (DoA) Monitoring System

Project is sponsored by MeitY vide Administrative Approval No. 1(1)/2022-ME&HI MeitY dated 28/03/2022 with financial support of Rs. 455.23 Lakh over a period of three (03) Years. Project is being implemented by NIELIT Imphal in the state of Manipur. The objective of the project is to pre-process publicly available EEG data. Achievement as on 31.09.2025:-

- Development of Methods for Pre-processing and Feature Extraction of EEG data – Completed
- Development of preliminary machine learning model for DoA Estimation – Completed
- Compilation of clinical EEG database with expert annotations – Completed
- Finalization of the machine learning model using clinical EEG data – Completed
- Development and Validation of the hardware architecture of the model – Completed
- Prototyping of the proposed hardware architecture on FPGA – Completed
- ASIC design for the proposed hardware architecture – In progress
- Finalization of test setup along with the test plan – In progress

#### 9.8.3.3 Skill Development of Youths in Aspirational Districts in area of IECT leading to enhancement in Employability

Project is sponsored by MeitY vide Administrative Approval 1411/10/2019-HRD dated 28/02/2020 with Financial Support of Rs. 29.81 Crore over a period of three (03) Years. Project has been at 21 States in 81 Aspirational Districts with a target to train 18,209 candidates. Under the project, a total of 18,803 candidates have been trained.

#### 9.8.3.4 Capacity Building and Training in Emerging Technologies for Enhancing Employment Opportunities and Skilling

Project is sponsored by MeitY, vide Administrative Approval No. L-14011/11/2021-HRD dated 26/03/2021 with Financial Support of Rs. 248.05 Lakh over a period of three (03) Years. The project is implemented by NIELIT Agartala to enable entrepreneurship & sustainable development among Youths of Tripura by providing Skill Development Training. Under the project, 1,437 candidates have been certified so far against the training target of 1,400.

#### 9.8.3.5 Digital Intervention of Handloom and Handicraft Sector for Livelihood enhancement of artisans of NE States

Project is sponsored by MeitY, vide Administrative Approval No. L-14011/12/2021-HRD dated 30/03/2021 with financial support of Rs. 619.12 Lakh, over a period of three (03) Years with the objective to setup Digital Enabled Common Facility Centre. Under the project, a total of 7,043 candidates have been trained against the total training target of 6,920.

### 9.8.3.6 Capacity Building in IECT including training in Digital Skill sets and Current Industry Demanding Technologies for various sections of society in the NE States [NECB 2.0]

Project is sponsored by MeitY vide Administrative Approval No. L-14011/33/2021-HRD, dated 02/02/2022 with financial support of Rs. 9232.76 Lakh over a period of two (02) Years. The project is jointly being implemented by NIELIT Guwahati, Kohima, Itanagar, Imphal, Shillong, Aizawl, Gangtok and Agartala with the aim of overall up-liftment of the socio-economic status of NE Citizens by creating a smart ecosystem with necessary IT education and skills. NIELIT has successfully implemented the project by training 1,71,710 candidates and met the total training target of 1,71,710.

### 9.8.3.7 ICT intervention in Travel & Tourism (T&T) Industry through Capacity Building in New Age Digital Technologies

Project is sponsored by MeitY, vide Administrative Approval No. L-14011/23/2021-HRD dated 18/02/2022 with financial support of Rs. 144.25 Lakh over a period of three (03) Years with the objective of empowering the youth with Digital skill including understanding of e-commerce digital transactions and associated concepts. NIELIT has successfully implemented the project by training 360 stakeholders and met the total training target (360 Nos.). In addition, e-content, LMS, VR content for tourists and it's hosting/Digital Dash Board etc. have been successfully created.

### 9.8.3.8 Self-employment Capacity building of the Engineering pass-out students belonging to Scheduled Caste/Scheduled Tribe community

Project is sponsored by MeitY vide Administrative Approval No. L-14016/2/2021-HRD dated 30/03/2021 with financial support of Rs. 443.73 Lakh over a period of three (03) Years. Project is being implemented jointly by NIELIT Patna, Haridwar, Chennai and Delhi (PMU). The objective of the project is to build the capacity of the Engineering pass-out students belonging to Scheduled Caste/Scheduled Tribe community. Under the project, 720 candidates are to be trained out of which 546 Candidates have been trained.

### 9.8.3.9 Work Based Learning (WBL) programme to Strengthen and Empower SC/ST/Women/EWS Graduate Engineers through MeitY Institutions

The Project is sponsored by MeitY vide Administrative Approval No. L-14011/19/2021-HRD dated 09/03/2022 with the financial support of Rs. 5140.18 Lakh over a period of five (5) years. The main objective of this programme is to provide an opportunity to SC/ST/EWS/Women candidates to acquire Technical Knowledge Expansion, Real time Working Skills, Technology Use, Problem Solving Skills, Reasoning, Analytical Thinking, Interpersonal Skill etc. on PAN India basis. Total 1957 interns are engaged by NIELIT Centres.

### 9.8.3.10 Future Skill Prime project (Programme for Reskilling/Up-skilling of IT Manpower for Employability)

Project is sponsored by MeitY vide Administrative Approval No. 14011/21/2017-HRD (Vol. II) dated 24/12/2019. Total estimated cost of the project is Rs 436.87 crore (approx.) with GIA of Rs. 433.21 Crore from the Central Government and 3.66 Crore to be incurred by NASSCOM over a period of Three (03) Years. The project is being implemented at NIELIT Calicut, Kolkata and Aurangabad (Lead Centres) and NIELIT Delhi, Agartala, Calicut, Gorakhpur, Chennai, Aurangabad, Chandigarh, Kolkata, Imphal, Gangtok, Guwahati, Kohima, Patna, J&K (Co-Lead Centres) providing training in the emerging technologies viz. Artificial Intelligence, Robotic Process Automation (RPA), Internet of Things (IoT), 3D Printing/Additive Manufacturing, Big Data Analytics, Virtual Reality/Augmented Reality, Cloud Computing, Cyber Security, Block Chain Technology and Social and Mobile . Under the project, 52,700 candidates have to be trained by NIELIT, out of which 31,838 candidates have been trained.

### 9.8.3.11 Development of Cyber forensic Training cum Investigation Labs in North-Eastern States and Cloud based centralized Cyber forensics Lab Infrastructure

Project is sponsored by MeitY vide Administrative Approval No 12(03)/2019-CSR, dated 25/03/2020 with the financial support of Rs. 1692.20 Lakh over a period of 5 years. The objective of this project is to setup cyber forensic training cum investigation labs in 8 North Eastern states equipped with associated cyber forensic system and tools. NIELIT has successfully implemented the project and the achieved are as under:

- Set up of Cyber Forensic cum Training Lab at 8 NIELIT Centres located in NE Region.
- Creation of resource portal along with e-learning methodologies over cloud and facilities for MIS, courseware dissemination, information exchange, resource persons/ organizations
- A total of 3107 candidates under (Awareness level, Beginners level, Advanced level and Judiciary level) have been completed out of the targeted 2680 candidates.
- Created a centralized database facility for digital crime tool profiling and usage of cyber forensic tools & reference library of various cyber forensic software tools for evidence extraction and analysis for cyber forensics
- Design and development of the course curriculum and its delivery for various stake holders

### 9.8.3.12 Capacity Building and Training on Cutting-edge technologies for employable youth of Tripura

Project is sponsored by MeitY vide Administrative Approval No L-14011/2/2022-HRD, dated 28/03/2022 with the financial support of Rs. 441.44 Lakh over a period of Three (3) years. The project is being implemented by NIELIT Agartala with the objective of enabling entrepreneurship & sustainable development among youth of Tripura by providing Training in cutting-edge technologies. Under the project total 3480 candidates are to be trained, out of which 3681 candidates have been trained so far.

### 9.8.3.13 Establishment of Design and Assembly Lab of solar LED based products

Project is sponsored by MeitY vide Administrative Approval No 14016/3/2021-HRD, dated 28/09/2022 with the financial support of Rs. 211.20 Lakh over a period of Three (3) years. The project is being implemented by NIELIT Leh with the objective of setting up a complete design and assembling lab of solar LED based products like Solar lanterns, Solar street lights etc. Under the project, 350 candidates are to be trained, out of which 332 candidates have been trained and set up of complete design and assembling lab of solar LED based products is under process.

### 9.8.3.14 Skilled Manpower Advanced Research and Training (SMART) Virtual Prototyping Lab at NIELIT Calicut

Skilled Manpower Advanced Research and Training (SMART) facility or Virtual Prototyping Lab is set up at NIELIT Calicut as part of the Chip to Start-up (C2S) programme of MeitY for the proliferation of advanced VLSI and Embedded system design training, research and electronics systems development across the country. The 'SMART' remote lab facility is available 24x7, and the students, researchers, and start-up industries can access the facility anytime and anywhere. Out of the target 1,00,000 candidates, a total of 80,205 have been trained.

### 9.8.3.15 Ultra Low Power SHAKTI RISC V Based Lightweight Edge AI Processor for IoT enabled Healthcare Applications

Project is sponsored by MeitY vide Administrative Approval No EE-9/2/2021-R&D-E, dated 15/01/2024 with the financial support of Rs.288 Lakh over a period of five (5) years. The Project is being implemented by NIELIT Aurangabad with the objective of Design and Development of Indigenous Edge AI Coprocessor for IoT healthcare applications, Design of energy-efficient coprocessor capable of seamless integration into various healthcare IoT devices & Development of functional prototypes of healthcare applications leveraging the coprocessor's local data processing capabilities.

Under the project, setting up of DIR-V based SoC and Embedded System Design Labs & the installation of Synopsys, CADENCE and Mentor Graphics VLSI Design tools have been completed. Achievement as on 31.10.2024: -

- DIR-V SoC and Embedded Design Labs established – *Completed*
- High-Level Design Document developed jointly with NIT & IIIT Trichy – *Completed*
- DIR-V Processor architecture familiarization and RTL analysis – *Completed*
- Edge AI Processor micro-architecture and low-level design prepared with NIT & IIIT Trichy – *Completed*
- EEG, EMG, ECG, and EOG sensor interfacing with OpenBCI Cyton board – *Completed*
- ADS1299-based bio-signal acquisition board for ZYNQ using SPI communication – *Completed*
- Sub-blocks for RISC-V CDAC VEGA Processor developed; preliminary NPU verification – *Completed*
- Component procurement for analog front-end PCB (EEG, ECG, EMG, EOG) – *Ongoing*
- Pre-processing algorithm design and development – *Ongoing*
- SPI interfacing with ZYNQ UltraScale ZCU104 FPGA board – *Completed*
- 22 DRDO officials trained in PCB Design, Fabrication & Testing using C2S EDA tools – *Completed*
- Reviewing NPU RTL design and specifications to understand core functionality- *Ongoing*

#### **9.8.3.16 Empowering Police Personnel and Government Officials of NE States through IT and Cyber Security Training**

Project is sponsored by MeitY vide Administrative Approval No L-14011/7/2023-HRD, dated 26-02-2024 with the financial support of Rs. 2245.47 Lakhs over a period of three (3) years. The Project is being implemented by NIELIT Kohima with the objective to train Police Personnel and Government Officials of NE States through IT and Cyber Security Training through a comprehensive training program with setting up IT cum Security labs equipped with the latest hardware and software at different police headquarters and selected districts in NE States. Under the project, a total of 8,714 Police personnel & Govt. officials have been trained out of the assigned target of 18,660.

#### **9.8.3.17 Electronics & ICT Academy Scheme, Phase-II**

Project is sponsored by MeitY vide Administrative Approval No L-14011/1/2024-HRD, dated 26-04-2024 with the financial support of Rs. 9468.82 Lakh over a period of five (5) years. The Project is being implemented by NIELIT Aurangabad, NIELIT Calicut, NIELIT Gorakhpur along with 11 other institutes (IITs, CDACs & NITs etc.). The objective of the project is to conduct faculty/mentor training through specialized Faculty Development Programs (FDPs) with the vision of MeitY by promoting emerging areas of technology and other high priority areas that are pillars of both, the “Make in India” and the “Digital India” programmes in ITI/Polytechnic. The target of the NIELITs is to train 7500 faculties & also to develop 60 Faculty Development Programs (FDPs) on emerging Technologies. A total of 3,029 faculties have been trained .

#### **9.8.3.18 Capacity Building for human resource development in Unmanned Aircraft System (Drone and related Technology) :**

Project is sponsored by MeitY vide Administrative Approval No L-14011/29/2021-HRD, dated 11.07.2022 with the financial support of Rs. 89.87 Crore over a period of five (5) years. The Project is being implemented by NIELIT Aurangabad, NIELIT Bhubaneswar, NIELIT Calicut, NIELIT Imphal & NIELIT J&K. The objective of the project is to leverage collaborative activities in human resource development through capacity building in education and training in the area of Unmanned Aircraft System (UAS). Under the project, 5425 Candidates have been trained as against the target of 8100.

### **9.8.3.19 Skill Development of unemployed youths of Odisha, Jharkhand, West Bengal, and Bihar for enhancing Employability and enabling Entrepreneurship towards Sustainable Development of States**

Project is sponsored by MeitY vide Administrative Approval No L-14011/8/2023-HRD, dated 24.05.2024 with the financial support of Rs.5076.39 Lakh over a period of three (3) years. The Project is being implemented by NIELIT Bhubaneswar, NIELIT Ranchi, NIELIT Kolkata & NIELIT Patna. The Objective of the project is to conduct free Skill Development programme to enhance employability and enable entrepreneurship towards sustainable development among youths of Odisha, Jharkhand, West Bengal and Bihar through various NSQF aligned courses under IT and Electronics domain. Training activities yet to be started. The target of the project is to train 50040 candidates out of which 9199 candidates have been registered and 3384 have been trained.

### **9.8.3.20. Employability Enhancement & Livelihood Training Program [EELTP] of SC/ST& EWS (Women) Youth through Capacity Building and Skill Development in IECT**

Project is sponsored by MeitY vide Administrative Approval No. L-14016/2/2022-HRD, dated 12/10/2022 with financial support of Rs. 9090.42 Lakh over a period of three (03) Years. The project is jointly being implemented by 21 NIELIT Centres with the aim of capacity building and skill development of SC/ST & EWS (Women) youth in IT and Electronics Sectors to enhance their employability and livelihood in SC/ST populous districts of States/UTs by imparting training in selected futuristic and upskilling courses. Target is 52,300 candidates to be trained in 3 Year in 100 districts. Under the project, at total of 18,430 candidates are registered, and a total of 9,573 candidates have been trained.

### **9.8.3.21. Setting up of IndiaAI Labs for Empowering the Youth by Imparting Training in Emerging AI Technologies**

The project is sponsored by MeitY vide Administrative Approval No ET/26/2024-ET, dated 21.10.2024 for a period of 3 years, the total budget outlay of Rs. 14.62 Crore. Under the project, the target is to set up 27 state of art AI Labs at 27 NIELIT Centers situated in tier- 2 & tier- 3 cities of India, and to train 10,800 candidates in emerging AI Technologies. Under the project, all Labs have been set up total 1801 No. of candidates have been trained and Setting up of India AI Data & AI Labs at 27 NIELIT Centres is completed.

### **9.8.3.22. Training of Govt. Employees in Digital Forensic**

Project is sponsored by MeitY vide Administrative Approval No. CLDG/53/2024-CLandDG dated , 20.11.2024 with financial support of Rs. 200 Lakh over a period of 18 months. The objective is to enhance the digital forensics capabilities of government employees through a comprehensive hands-on practical training program. 2000 government officials will be trained in Digital Forensics through 34 instructor-led online sessions. So far, 673, government officials have been trained.

### **9.8.3.23 Information Security Education and Awareness (ISEA) project – Phase-III**

Project is approved by MeitY vide Administrative Approval No. L-14017/1/2022 with budget outlay of Rs. 332.74 Crore for a period of 05 years and is implemented at 5 NIELIT Centres. The objective of the project is to create a robust mechanism for training and certification of CISOs to develop highly skilled and capable cyber security professionals for Government and other sectors (MSME, start-ups, non-IT sectors etc.). The target is to conduct 625 Boot camps, to train 1250 candidates through short term courses & publication of 50 Technical Paper. Under the project, 237 Bootcamps have been conducted, 763 candidates have been trained through short term courses and 22 Technical Paper have been published.

#### 9.8.3.24 Design and development of Ultrasonic transducer probes for medical imaging

Project is sponsored by MeitY vide administrative approval F. No. 1(3)/2019-ME&HI, dt-13.08.2021. The primary objectives of the project is to Design of ultrasound probes, Development of piezoelectric Transducer, Development of backing and matching Layers, Fabrication of transducer probes, Validation and clinical trials of developed Probes. Achievement so far is as under:

- Design and development of Ultrasonic Probe Test jig – Completed
- Development of a test setup for testing the transducer probe elements (Open/Short test - capacitance based) and develop GUI for displaying the test- Completed
- Testing and evaluation of the Ultrasound probe prototype developed by C-MET Trissur using the Research platform available at NIELIT Calicut - The IEC and other testing of the developed probe is Under progress.
- Probe development completed.
- The IEC and other testing of the developed probe is Under progress.
- After the testing probe clinical trials to be completed.

#### 9.8.3.25 Indigenous state-of-the-art FPGA- based ultrasound beam former modules for Affordable Ultrasound scanners: A Proof-of-concept scanner development

Project has been approved by Ministry of Science & Technology Department of Biotechnology vide administrative approval No BT/PR49659/MED/32/893/2023 Dated 21.03.2024. The primary objectives of the project proposal to VLSI Architecture design for identified state-of-the-art algorithm, Design and implementation of Ultrasound Beamforming Accelerator on FPGA and Verification of the implementation results. Achievement so far is as under:

- VLSI and system architecture designed for state-of-the-art ultrasound beamforming algorithms.
- FPGA emulation of ultrasound beamformer core completed with performance analysis and verification.
- CFB-DAS and DB-SAT beamforming architectures developed for XC7A100T and XCZU5EG (PYNQ-ZU) FPGAs.
- CFB-DAS beamformer implemented and tested on XCZU5EG in two modes (real-time and precomputed delay).
- Integration of CFB-DAS and DB-SAT beamformers with data acquisition setup – In progress.
- initiated by CMET Thrissur

#### 9.8.3.26 Smart Bioinformatics Ecosystem:Leveraging AI and Cloud Technology for Innovation and Capacity Building in Bioinformatics.

Project is sponsored by MeitY vide Administrative Approval L-14011/14/2025-HRD dated 19/08/2025 with Financial Support of Rs. 18.04 Crore over a period of three (03) Years. Project has been Implemented by NIELIT, Guwahati with a target to train 23430 candidates. Under the project, a total of 348 candidates have been trained.

#### 9.8.3.27 SAMARTH - Students Advancing Mindsets in AI, Robotics, Technology, and Digital Hardware.

Project is sponsored by MeitY vide Administrative Approval L-14011/12/2025-HRD dated 01/09/2025 with Financial Support of Rs. 50.50 Crore over a period of three (03) Years. Project has been Implemented by NIELIT, Kohima with a target to train 153400 candidates. Under the project, a total of 1109 candidates have been trained.

#### 9.8.4. Synergy through Collaborations and MoUs

- **MoU with INSPIRA** : NIELIT has signed an Memorandum of Association (MoA) with INSPIRA India on July 25, 2025 to bring NVIDIA's Deep Learning Institute (DLI) courses to students & researchers. MoU was signed in the presence of Dr. M. M. Tripathi, DG, NIELIT, Mr. Ganesh Mahabala, Director, NVIDIA, Sh. Vivek Harinarain (IAS), Advisor, Inspira & others. This collaboration aims to empower India's tech talent with industry-relevant AI & Deep Learning education, boosting skill development and innovation. NIELIT and INSPIRA will shape the future of AI in India together.
- **MoU with Kyndri**: NIELIT had already signed a MoU with Kyndryl Solutions Private Limited to run the joint Kyndryl-NIELIT Advanced Skilling Program in DevSecOps, designed to benefit the students from marginalized communities. On 18th July 2025, Ms. Una Pulizzi, Global Head of Corporate Affairs, Kyndryl, visited NIELIT to further strengthen the collaboration in capacity building. The visit also marked the successful certification of 113 candidates from the 1st batch of the DevSecOps course. The 2nd batch has been launched with 103 candidates enrolled from across India.
- **MoU with UP Madhyamik Shiksha Parishad (UPMSP)**: NIELIT signed MoU with UP Madhyamik Shiksha Parishad (UPMSP) on 28th April, 2025 to skill Class 9 - 12 students through 'O' Level training across 757 Govt. schools of Uttar Pradesh. As a outcome of the MoU, approximately 40,000+ students/year are expected to gain expertise in emerging technology & build career pathways.
- **MoU with Infineon Technologies**: NIELIT has signed a MoU with Infineon Technologies on March 17, 2025 in the presence of Hon'ble Union Minister of State, Sh. Jitin Prasada to boost innovation & skill development in semiconductors & embedded systems.
- **MoU with the Indian Institute of Drone Technology (IIDT)**: On 12th March, 2025, NIELIT has signed an MoU with the Indian Institute of Drone Technology (IIDT) to drive skill development, training & innovation in drone technology. Empowering students & professionals with cutting-edge expertise in the rapidly growing UAV sector.

### 9.9 Software Technology Parks of India (STPI)

#### 9.9.1 Introduction

Software Technology Parks of India was set up in 1991 as an autonomous society under the Ministry of Electronics & IT (MeitY), Government of India. STPI's main objective has been the promotion of software exports from the country. STPI acts as 'single window' in providing services to the software exporters. The services rendered by STPI have been statutory services, High Speed Data Communication (HSDC) services, State-of-the-art Incubation services, Cyber Security Service, Project Management & Consultancy services and IT Managed services/co-location services to the satisfaction of the IT Industry. STPI has played a key developmental role in the promotion of software exports with a special focus on SMEs and startup units. Apart from this, STPI is also executing various initiatives i.e. Centres of Entrepreneurship (CoEs), Next Generation Incubation Scheme (NGIS) etc. for promotion of startup ecosystem in the country.

STPI has been implementing the Software Technology Park (STP) scheme and the Electronics Hardware Technology Park (EHTP) scheme for the promotion of IT/ITES/ESDM industry. The phenomenal success of the IT/ITES industry has been possible, inter-alia, due to pivotal role played by the STP Scheme. STP Scheme is a unique scheme, designed to promote the software industry and growth of Start-Ups and SMEs without any locational constraints. As on 31st December 2025, 5647 IT/ITeS STPI registered units are exporting, and 46 units are exporting under EHTP scheme.

In FY 2025-26 (till 31st December 2025), IT/ITES export from STPI registered units stands at Rs. 8,60,686.78 crore (tentative) and Electronics Hardware export of Rs. 5331.79 crore (tentative) under EHTP scheme.

### 9.9.2 STPI Centres

To provide statutory and incubation services to industry, major thrust was given on the establishment of new centres as well as revamping of existing centres. As on date, a total of 68 STPI centres/ Sub-centres are operational across the country, out of which 60 centres are in Tier II and Tier III cities.

STPI is working closely with the respective State Governments/local authorities for creation of more space, equipped with state-of-the-art infrastructure facilities, for development of the software industry and increasing exports.

#### Services:

The main services rendered by STPI for the software exporting community are as below:

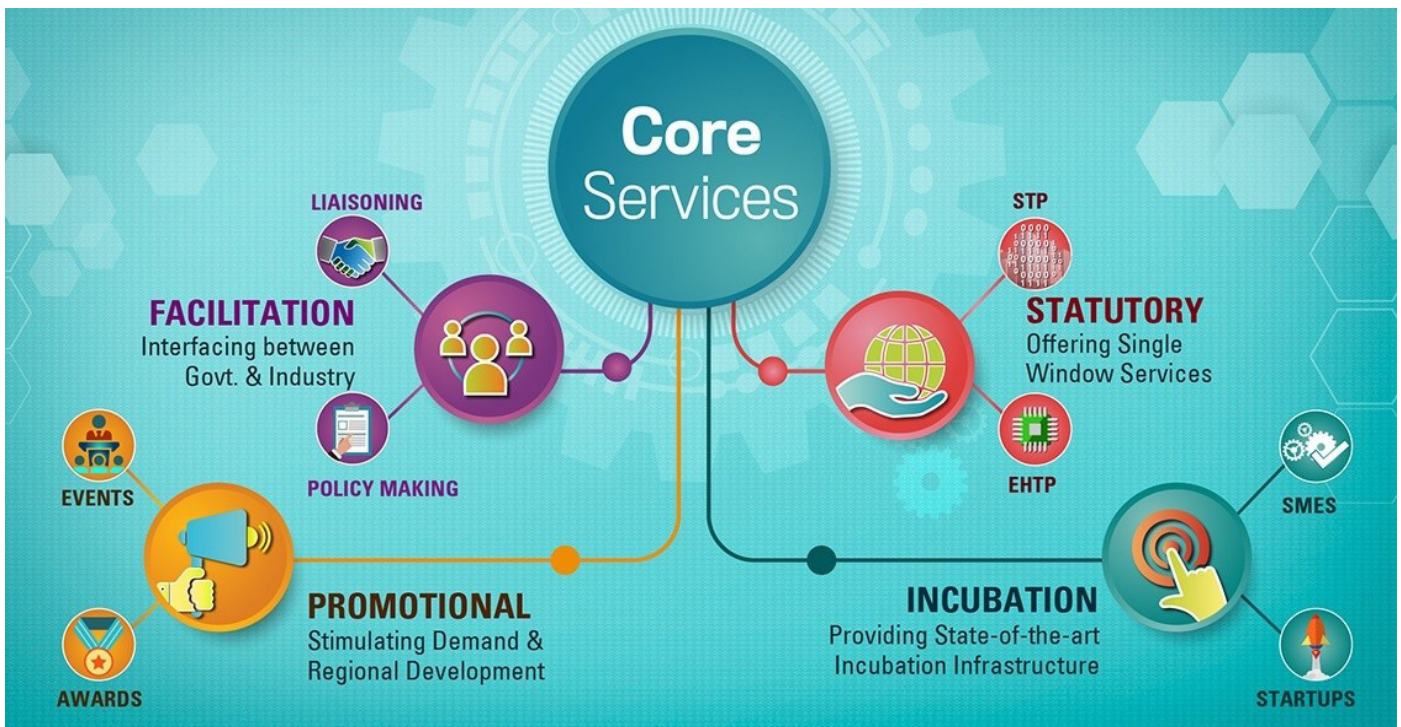

- **Statutory Services**

STPI provides Single Window Clearance to Software exporters under the STP/EHTP Schemes. STP scheme provides these units with various benefits, making it a phenomenal success.

- **Incubation Facilities**

Business and technology incubation stimulate the growth of startups. STPI is offering ultra-modern office facilities to small units and entrepreneurs. Plug-n-Play facilities for startups enable short gestation period. This has encouraged many entrepreneurs to start their own operations and grow in a competitive environment.

- **Datacom Services**

One of STPI's remarkable contributions to the software-exporting sector is provision of High-Speed Data Communication (HSDC) services. STPI has designed and developed state-of-the-art HSDC network called SoftNET for software exporters. Local access to international gateways is provided through point-to-point and point-to-multipoint microwave radios which has overcome the last mile problem and enabled STPI to maintain an uptime more than 99%.

- **Consultancy Services**

STPI provides consultancy and Project Management Services and turnkey solution to various national and International organizations in the areas of Communication Networks, Network Operation Centres, Network Management Systems, Computerization, e-Governance networks etc. The technology capability coupled with process strengths has enabled STPI to secure a number of projects from time to time.

- **Cybersecurity Services**

STPI is empanelled with the Indian Computer Emergency Response Team CERT-In, MeitY, ensuring compliance with the highest standards of cybersecurity practices mandated by the Government of India. STPI offers end-to-end Vulnerability Assessment and Penetration Testing (VAPT) services to identify, assess, and mitigate security vulnerabilities in software applications, network infrastructure, and IT systems. Our approach helps organizations proactively manage threats and strengthen their cybersecurity posture

STPI conducts comprehensive cybersecurity audits and compliance assessments to ensure adherence to key national and international standards. These audits help organizations identify gaps, enforce security best practices, and meet regulatory requirements

STPI specializes in the design, implementation, and management of robust cybersecurity frameworks tailored to organizational needs. We deploy advanced security tools, risk mitigation techniques, and global best practices to protect digital infrastructure and sensitive data from unauthorized access and cyber threats

- **Data Centre and Cloud Services**

To fulfil industry needs, STPI has been creating a strategic infrastructure to facilitate high availability, quick scalability, efficient management & optimised utilization of resources.

- o Operating six state-of-the-art Data Centres at Chennai, Bengaluru, Mohali, Bhubaneswar, Noida and Vijayawada with a total area of around 55,000 sq. ft. and rack capacity of around 700.
- o Catering to the needs of Government Organization/ Institutions/ Industries etc., ensuring availability, reliability and security of its customers.
- o Providing hosting and fully managed services, including monitoring, updates and system maintenance
- o Specialised in the design, establishment and end-to-end management of Data Centres tailored to client requirements
- o STPI's infrastructure and systems assure disaster recovery and offer minimal downtime during disruptions, ensuring business continuity
- o Data Centres are also equipped with 24x7 help desks and a Network Operations Centre (NOC)
- o Presence of data centres across different seismic zones.
- o Hosted in STPI Data Centres, Ananta Cloud platform by STPI is an indigenous cloud infrastructure solution tailored to meet the requirements of government organizations, enterprises, and startups by providing secure, reliable, and scalable cloud services across India. Ananta offers the Government Community Cloud (GCC) and Hybrid cloud services.

### 9.9.3 Centres of Entrepreneurship (CoEs)

For ensuring India builds leadership in the emerging technologies such as IoT, Blockchain, FinTech, Artificial Intelligence, Augmented & Virtual Reality, Medical Electronics & Healthcare, Gaming & Animation, Machine Learning, Data Science & Analytics, Cyber Security, Chip Designing, ESDM, etc. and to build next wave of budding entrepreneurs, STPI is setting up several domain-focused CoEs in collaboration with suitable partners in various parts of country. These CoEs

function as single-window facilitation centre with an aim to provide comprehensive structural & fundamental support including lab & incubation, training, mentoring, hand-holding, access to funds, networking, market connect etc. through a collaborative effort of Govt. of India, various State Govts., Industry, Academia, Domain & Technology Experts, Venture Capitalists and other startup ecosystem players. This collaborative model of the CoEs is further extended with an eminent personality from industry/academia/start-ups onboarded as “Chief Mentor” who would also act as brand ambassador of the CoE.

The CoEs are planned with dedicated operational team & support staff to take care of strategy, operations, networking, outreach, mentoring & other services with a clear focus on nurturing & promoting startups to develop world-class IT products & IPR domestically and become “job creators”.



As on date, STPI has operationalized the following 24 domain focus CoEs in collaboration with suitable partners in various parts of the country:

- Electropreneur Park 2.0 at IIIT Delhi
- IoT OpenLab at STPI-Bengaluru
- FINBLUE at STPI-Chennai
- Electropreneur Park, an ESDM CoE at STPI- Bhubaneswar
- NEURON at STPI-Mohali
- VARCoE at IIT Bhubaneshwar
- IMAGE at STPI-Hyderabad
- APIARY at STPI-Gurugram
- MOTION at STPI-Pune
- MedTech at SGPGI Lucknow
- Atal Incubation Centre (AIC) at STPI-Bengaluru
- OctaNE - IoT in Agriculture CoE at STPI-Guwahati
- OctaNE - Animation CoE at STPI-Shillong
- OctaNE - AR/VR CoE at STPI-Imphal

- OctaNE - IT Applications in Health care & AgriTech CoE at STPI-Gangtok
- OctaNE - GIS Applications including Drone Tech CoE at STPI-Itanagar
- OctaNE - IT Applications in Graphic Design CoE at STPI-Kohima
- OctaNE – Gaming & Entertainment CoE at STPI- Aizawl
- OctaNE - Data Analytics & AI CoE at STPI-Agartala
- Efficiency Augmentation CoE at Bengaluru
- FASAL at Dr. Panjabrao Deshmukh Krishi Vidyapeeth Akola
- Kalpatru at RINL Visakhapatnam
- Emerging Technology CoE at Bhubaneswar & Satellite Centre at BPUT, Rourkela
- FinGlobe – FinTech CoE at Gandhinagar, Gujrat.

The STPI CoEs are enabling a 360-degree support ecosystem in the form of state of art Infrastructure, hand holding & funding support, Mentoring & Networking opportunities to nurture innovative start-ups in emerging technologies and making India a “Product Nation”. Collectively, 24 operationalized CoEs through well-publicized Open challenge programs and contests have selected a total of 2195 startups, out of which 1122 are onboarded.

As an outcome, these start-ups have transformed their brilliant ideas into 1452 path-breaking products, 724 IPRs created and have showcased 1671 prototypes.

A brief overview and status of each STPI CoE is given below:

- **Electropreneur Park (EP) 2.0 at IIIT Delhi**

Electronic System Design and Manufacturing (ESDM) is one of the fastest growing sectors of the Indian economy. In order to support the new entrepreneurs of this industry, STPI in association with the Ministry of Electronics & IT (MeitY), Technology Innovation Hub (iHub Anubhuti), Indian Electronics Semiconductor Association (IESA) & academic partner, has set up an Electropreneur Park 2.0 in Delhi.

EP 2.0 Delhi aims to support 200 startups in ESDM sector including cognitive computing & social sensing, nurture start-ups and design entrepreneurs to promote India’s capabilities in ESDM, nurture service / trading MSME to ‘Make in India’, generate IPRs & products. EP 2.0 Delhi focuses on local IP creation and indigenous product development resulting in increased domestic value addition and witnesses a unique integration of academia, industry, government and other incubation supportive elements.

Building upon the success of Electropreneur Park (EP) 1.0 Delhi, India’s first of its kind ESDM incubation centre successfully executed in the pilot years (2016-2023) by impacting 59 start-ups in the ESDM domain and delivering a value of over ₹ 640 Crore. The initiative is first of its kind in industry and it has set a role model which may go a long way in the annals of incubation centres.

EP 2.0 Delhi has onboarded 10 startups, resulting in the development of 41 prototypes and 19 products by these start-ups.

- **NEURON at STPI Mohali**

The NEURON CoE at Mohali has vision to promote entrepreneurial spirit amongst youth, researchers, engineers and society at large by promoting cutting edge information technology startups especially in the field of AI/Big Data, AVG and IoT. The CoE has been established in collaboration with MeitY, Govt. of Punjab, ISB-Mohali, Punjab Technical University PTU) and industry to provide complete handholding & support to innovative startups in the field of AI/Data Analytics, IoT and AVG.

NEURON has onboarded 114 startups and resulting in the development of 171 prototypes and 158 products by these start-ups.

- **VARCoE at IIT Bhubaneswar**

With an intention to create an ecosystem for carrying out R&D in immersive visualization, giving impetus to R&D, Incubation, IP Creation, Product Development, Skill development and Entrepreneurship in AR, VR and allied fields, VARCoE has been established at IIT Bhubaneswar. This CoE aims to support startups, individual researchers and high R&D projects in Health, Art and Architecture, Transport, Construction, Tourism, Entertainment, and Education. VARCoE has started operations with first set of projects working on various applications of VR/AR.

Presently, 9 major projects on AR&VR applications in various domains involving 12-15 highly qualified faculty and researchers of IIT Bhubaneswar are in progress. VARCoE has onboarded 25 startups, resulting in the development of 27 prototypes and 28 products by these start-ups.

- **IMAGE at STPI Hyderabad**

A CoE in the field of Gaming, VFX, CV & AI has been established at Hyderabad in partnership with MeitY, Govt. of Telangana, academia, & industry partners like HYSEA (Hyderabad SW Enterprises Association) & TVAGA (Telangana VFX, Animation & Gaming Association). Facilities & Services include 10,000 sq. ft. incubation space and an IMAGE lab with cameras, display units & related equipment in an area of 3,500 sq. ft. The IMAGE Lab consists of Motion Capture (MoCap) facility and computing facility or Computer Vision & AI.

IMAGE has onboarded 103 startups, resulting in the development of 168 prototypes and 230 products by these start-ups.

- **APIARY at STPI Gurugram**

A CoE in Blockchain Technology branded as APIARY has been established in collaboration with MeitY, STPI, STPINEXT, Govt. of Haryana, Padup Venture Private Limited, IBM, Intel, GBA and FITT. This is an initiative, to identify and evaluate promising startups in the field of Blockchain Technology that will be hosted in STPI Gurugram.

APIARY has onboarded 62 startups, resulting in the development of 34 prototypes and 43 products by these start-ups.

- **MOTION at STPI Pune**

A CoE in the Autonomous, Connected, Electric & Shared (ACES) branded as MOTION has been established in collaboration & partnership with Government of Maharashtra, M/s. Tata Motors, M/s. Kinetic, M/s. Visteon, M/s. MathWorks India, M/s. Intel, College of Engineering Pune (CoEP) and associations like ARAI, SAE-India, TiE-Pune etc.

MOTION has onboarded 55 startups, resulting in the development of 140 prototypes and 107 products by these start-ups.

- **Atal Incubation Centre (AIC) at STPI Bengaluru**

STPI has established the Atal Incubation Centre (AIC) at Bengaluru in collaboration with Atal Innovation Mission, NITI Aayog.

AIC has onboarded 65 startups, resulting in the development of 98 prototypes and 64 products by these start-ups.

- **OctaNE CoEs in North East Region (8 no. viz. IoT in Agriculture at STPI-Guwahati, Animation at STPI-Shillong, AR/VR at STPI Imphal, IT Applications in Healthcare & Agri Tech at STPI-Gangtok, GIS Applications including Drone Tech at STPI-Itanagar, IT Applications in Graphic Design at STPI-Kohima, Gaming & Entertainment at STPI-Aizawl and Data Analytics & AI at STPI-Agartala)**

Eight CoEs with Startup Innovation Zone (SIZ) along with e-commerce facilitation were envisioned to be established by STPI in each state of North East Region in phase wise manner.

Accordingly, 8 CoEs are established under OCTANE, 3 as part of Phase-I viz. IoT in Agriculture - Guwahati, Emerging Tech (AR/VR) - Imphal, Gaming & Animation – Shillong and 5 as part of Phase-II viz. Gaming & Entertainment - Aizawl, GIS Applications (incl. Drone Technology) - Itanagar, IT Application in Graphic Design - Kohima, Data Analytics & AI - Agartala, IT in Healthcare & AgriTech Gangtok. OctaNE CoE+SIZs work in collaborative manner with one another or on a regional basis.

OctaNE has onboarded 285 startups resulting in the development of 232 prototypes and 292 products by these start-ups.

- **Efficiency Augmentation at Bengaluru**

The CoE has been set up by STPI in collaboration with Government of Karnataka, Hewlett Packard Enterprise, Vidyarthi Shikshana Seva Trust (VSS Trust), Yuvaka Sangha and India Electronics and Semiconductor Association (IESA). The CoE shall be of international standard which seeks to bring together the international community, Industry to debate, deliberate, act and innovate in both the industry (infrastructure & business transformation) and people development, in order to address technology's impact on Industry.

The CoE has onboarded 21 startups resulting in the development of 127 prototypes and 70 products by these start-ups.

- **FASAL at Dr. Panjabrao Deshmukh Krishi Vidyapeeth Akola**

The IoT is a perfect match for smart farming due to its highly interoperable, scalable, pervasive, and open nature. Realizing this enormous potential of IoT technologies for smart farming, FASAL (Fostering Agritech Startups for Augmenting Livelihood), an IoT in Agriculture CoE, is being set up by STPI at Akola to identify & evaluate promising startups in the field of AgriTech & Agri IoT and nurture them to build path-breaking products in the focused areas including Digital Farming, Crop Protection & Management, Predictive Analytics & Hydroponic VF System.

The CoE FASAL is set up in collaboration with partners & leading stakeholders from Government, Academia, Industry & Industry Associations. The stakeholders are Ministry of Electronics & Information Technology (MeitY), STPI, Dr. Panjabrao Deshmukh Krishi Vidyapeeth (PKDV) Akola and other partners include ICAR-Indian Agricultural Research Institute (IARI), Agriculture Insurance Company of India Ltd. (AIC), Krishi Vigyan Kendra (KVK) Akola, College of Engineering & Technology Akola, SatSureAnalytis India Pvt. Ltd, Amazing Aerial Solutions Pvt. Ltd., ioCare, Indian Society of Agricultural Engineers (ISAE) and TiE Mumbai.

FASAL has onboarded 38 startups, resulting in the development of 53 prototypes and 53 products by these start-ups.

- **KALPTARU Industry 4.0 CoE at RINL Visakhapatnam**

A CoE on Industry 4.0 to design and develop Industry 4.0 solutions for RINL-VSP, PSU's and other Industry present in and around Visakhapatnam as well as contribute to overall Indian Industry 4.0 requirements. With the above background, KALPTARU CoE in the field of Industry 4.0 (Artificial Intelligence, Machine Learning, Augmented Reality, Virtual Reality, Industrial Automation, Industrial Robotics, Industrial Drone, Industrial IoT, Industrial 3D Printing and other related technologies powered by AI) has been established at Visakhapatnam.

This CoE has onboarded 63 startups, resulting in the development of 14 prototypes and 24 products by these start-ups.

- **FinGlobe CoE at Gandhinagar**

FinGlobe CoE, has been set up by STPI in association with the Department of Science and Technology, Government of Gujarat, with an aim to serve as a catalyst for the development and proliferation of cutting-edge technologies within the financial services domain. By providing state-of-the-art infrastructure, expert mentorship, and a collaborative ecosystem, FinGlobe CoE seeks to empower startups, entrepreneurs, and established players to ideate, innovate, and scale their solutions in the FinTech, TechFin, Banking Industry, and allied domains.

FinGlobe CoE has onboarded 5 start-ups, resulting in the development of 1 prototype and 8 products.

#### 9.9.4 Modified Electronics Manufacturing Cluster (EMC 2.0) Scheme

The EMC 2.0 scheme was notified on 1st April 2020 with an implementation period of 8 years (i.e., up to March 2028). The objective of the EMC 2.0 scheme is to create a comprehensive supply chain/ecosystem for strengthening electronics manufacturing base, attract Anchor Units to set up production along with their supply chain, build world class plug-n-play infrastructure and reduce the infrastructure & logistics cost. Total budgetary support for the scheme is Rs. 3,762 crores. STPI is the Project Management Agency (PMA) for implementation of the scheme.

The financial assistance that is entitled to under EMC 2.0 are as stated below:

- EMC project: Up to 50% of project cost with ceiling of ₹70 crore for every 100 acres of land. Overall financial assistance for an EMC project cannot exceed ₹350 crore per project.
- Common Facility Centre (CFC): Up to 75% of project cost with ceiling of ₹75 crore per project.

This scheme will bring huge investment to India so that India can become the topmost destination in Electronics Manufacturing. The scheme was open for receipt of applications till 31st March 2024, and 31 applications have been received on EMC 2.0 portal.

- a. 13 EMC/CFC projects (11 EMCs + 2 CFCs) have been approved across the following states:  
 EMC – 11 (Andhra Pradesh, Gujarat, Haryana, Maharashtra, Karnataka (2), Uttarakhand, Telangana, Tamil Nadu (2), Uttar Pradesh)  
 CFC – 2 (Telangana, Chhattisgarh)
- b. Additionally, 3 EMC projects viz. Gujarat (2) and Madhya Pradesh have received approval from the Project Review Committee.
- c. Total project cost is INR 5,226.49 Cr, with approximately INR 2,492.74 Cr earmarked as Central Financial Assistance for these projects.

#### 9.9.5 Promotion of Small and Medium Entrepreneurs by creating a conducive environment in the field of Information Technology

STPI has been promoting SMEs and their cause by offering incubation services, organizing events, sponsoring/co-sponsoring events, participating in events and export promotion efforts.

Some of the major events in which STPI participated/sponsored include:

- 18th edition of the Pravasi Bharatiya Divas was held from 8th to 10th January 2025 in Bhubaneswar, Odisha.
- SEAP Star Awards 2025 is being held on 17th Jan 2025 in Pune.
- Bharat AI Cyber & Automation Summit 2025 was held on 6th February 2025 in New Delhi.
- International Trade Conclave was held on 7th February 2025 in New Delhi.
- Radiant Jharkhand is held from 20th to 22nd February 2025 in Jamshedpur.
- India Blockchain Horizons 2025 held on 24th February 2025 in New Delhi.
- PRAVAAH – MeitY Incubators Conclave 2025 held on 25th February 2025 in Goa.
- The 10th edition of the annual IT Event TIECON Chandigarh 2025 held on 6th & 7th March 2025 in Chandigarh.
- The 19th Edition of IESA Vision Summit 2025 was held from 5th March to 7th March 2025 in Gandhinagar, Gujarat.

- TiEcon Mumbai 2025 was held on 11th & 12th March 2025 at Jio World Convention Centre, Mumbai.
- NASSCOM SME Confluence 2025 was held in Ahmedabad on 12 March, in Trivandrum on 18 March, and in New Delhi on 20 March 2025.
- Bharat Digital HealthCare Summit 2025 was held on 12th April 2025 in New Delhi
- Bharat 6G 2025 - 3rd International Conference & Exhibition held on 14th May 2025 in New Delhi.
- 'Rising North East' - Investors Summit organized by MDoNER held on 23rd and 24th May 2025 at Bharat Mandapam, New Delhi.
- VivaTech 2025 - Europe's premier technology and innovation summit was held from 11th to 14th June 2025 in Paris.
- DD Robocon 2025 was held from 12<sup>th</sup> to 13<sup>th</sup> July 2025 in New Delhi.
- Government Achievement & Scheme Expo-2025 was held from 21st to 23rd June 2025 at Bharat Mandapam, New Delhi.
- Digital Infrastructure Summit was held on 25th June 2025 in New Delhi.
- IICA North East Conclave 2025 held on 11–12 July 2025 at IIM Shillong.
- TiECon Bhubaneswar 2025 was held on 9-10 August 2025 in Bhubaneswar.
- Global Artificial Intelligence (AI) Summit & CII National AI Awards 2025 held on 4th September 2025 at New Delhi.
- The 23rd edition of CII Connect 2025 held on 16th–17th October 2025 at Coimbatore.
- TiEcon Delhi 2025 held on 29th–30th October 2025 in New Delhi.
- IndiaJoy 2025 event held from 1st to 2nd November 2025 at HICC, HITEX, Hyderabad.
- India Game Developer Conference 2025 held from 5th to 7th November 2025 at Chennai Trade Centre, Chennai.
- Bharat CyberSuraksha Summit & Awards 2025 held on 7th November 2025 in New Delhi.
- Suraksha Summit & Awards 2025 held on 7th November 2025 in New Delhi.
- 11th Cloud & Data Centre India 2025 Annual Conference held on 12th November 2025 in Delhi.
- STPI co-hosted Bengaluru Tech Summit (BTS) 2025 held from 18th November to 20th November 2025 at Bangalore International Exhibition Centre (BIEC), Bengaluru.
- 16th AGROVISION 2025 event held from 21st to 24th November 2025 at Nagpur.
- STPI hosted Pre-Summit events across multiple locations such as New Delhi, Mysuru, Chennai, Kolkata, Goa, Guwahati, Mohali, among others.

### 9.9.6 Next Generation Incubation Scheme (NGIS)

NGIS aims to position India as a leading Software Product Nation by enabling it to become a global hub for the development, production, and supply of innovative, efficient, and secure software products, including embedded software. This initiative supports the overall growth of the ICT sector in line with the National Policy on Software Products (NPSP) – 2019.

The scheme operates from 12 Tier-II locations across India - Agartala, Bhillai, Bhopal, Bhubaneswar, Dehradun, Guwahati, Jaipur, Lucknow, Prayagraj, Mohali, Patna, and Vijayawada with the objective of supporting 300 startups/

entrepreneurs/SMEs in the IT/ITeS/ESDM domains and generating 50+ patents/IPRs over a 3-year period. The total budget allocation for NGIS is INR 95 crore.

The scheme's partners and stakeholders include MeitY, STPI, and a wide network of industry stakeholders, academia, and investment agencies, ensuring comprehensive support to product-focused startups. A total of 20 challenge programs under CHUNAUTI (Challenge Hunt Under NGIS for Advanced Uninhibited Technology Intervention) have been successfully completed.

Overall, 686 startups have been supported under NGIS through mentoring, stipends, and seed funding. Of these, 180 startups have been provided seed fund support, 359 startups have been provided with stipends support and all 686 have received mentoring, networking and other support. As of 31st December 2025, NGIS beneficiary startups have collectively developed 1174 products, have filed 377 patents and have generated employment for 9098 individuals. A new initiative, LEAP AHEAD (Launchpad for Tech Entrepreneurs towards Accelerated Growth and Pioneering AHEAD), was launched under NGIS to support scaling and growth-stage tech startups across India, particularly from Tier 2 and Tier 3 cities. The initiative aims to assist tech startups through high-quality mentorship, scale-up funding, and opportunities for global market access. It is designed for growth-stage startups seeking product diversification or expansion into new markets. STPI has launched two editions of LEAP AHEAD under NGIS.

- **First Edition:**

The program achieved significant success, supporting 87 high-potential startups through a structured mentorship framework and enabling 22 of them to explore global opportunities. In this edition, 50 startups secured funding commitments amounting to Rs. 78.86 crore, of which 35 startups received actual funding of Rs. 44.79 crore (as reported by the startups).

- **Second Edition:**

Building on the success of the first edition, STPI launched the second edition of LEAP AHEAD on 15th October 2024, which received an overwhelming response with 500+ applications. Out of these, 150 startups participated in screening rounds, and 60 high-potential startups were selected for the cohort. These startups were provided with high-quality mentorship, and 25 of them participated in a global connect program held in Silicon Valley, USA. In this edition, 21 startups have already received funding.

## 9.9.7 SAYUJ: The Start-up Community Network

### 9.9.7.1 About SAYUJ

- STPI launched SAYUJ, India's exclusive innovator community network platform to facilitate seamless connections among entrepreneurs, startups, investors, incubators, mentors, and other stakeholders within the ecosystem around innovation in emerging technologies.
- SAYUJ provides access to all critical resources & information under single umbrella, including pan-India challenges, contests & events, central & state government policies & schemes, mentorship opportunities, and investor connections, empowering innovators & startups to thrive in a competitive landscape.
- SAYUJ serves as a collaborative space where all members of the innovator community can share knowledge, leverage resources, and form valuable partnerships.
- SAYUJ envisages AI-driven recommendations, offering tailored resources and support that align with each startup's unique goals, ensuring they stay ahead in their entrepreneurial journey.
- SAYUJ is continuously gaining more & more / increased traction from the innovator community members. The following sections present a view of platform's current statistics.

### 9.9.7.2 SAYUJ's Statistics

**Table: SAYUJ's Statistics (till 31<sup>th</sup> December 2025)**

Registered Users	Resources	Start-up Contests
<ul style="list-style-type: none"> <li>Startups: 6500+</li> <li>Mentors: 500+</li> <li>Investors: 45+</li> <li>Incubators: 150+</li> </ul>	<ul style="list-style-type: none"> <li>State Startup Policies: 35</li> <li>Government Schemes: 150+</li> <li>Incubation Centers: 1100+</li> <li>Labs: 50+</li> </ul>	<ul style="list-style-type: none"> <li>Total Contests: 400+</li> <li>Active Contests: 40+</li> <li>Total Applications: 4320+</li> <li>Total Events: 520+</li> </ul>

### 9.9.7.3 What SAYUJ Users Can Seek and Offer

- **Startups & Founders/Cofounders:** Showcase products and solutions, connect with other startups, investors, incubators and mentors, hire through the Hiring Hub, engage with the community through posts and messages, share success stories, explore trending content, access a repository of state startup schemes and government policies, incubators, co-working spaces, labs and more, discover and participate in contests and events nationwide.
- **Mentors:** Offer expert guidance, share insights, and connect with promising startups.
- **Investors:** Discover and invest in innovative startups and engage with entrepreneurs and fellow investors.
- **Incubators/Accelerators:** Host contests, events and hackathons, publish problem statements, screen applications, and provide resources and support.
- **Individuals & Professionals:** Explore entrepreneurship opportunities, connect with startups, mentors, and investors, and contribute to the community.

### 9.9.7.4 SAYUJ's Current Offerings

- **Connect:** Facilitating connections across the entire startup ecosystem.
- **Collaborate:** A LinkedIn-like networking platform for meaningful interactions.
- **Converse:** A personalized dashboard with tailored feeds for enhanced engagement.
- **Access to Pan-India Startup Contests and Events:** Stay updated on opportunities nationwide.
- **Resource Discovery:**
  - Information on state startup policies and incentives.
  - Comprehensive listings of government schemes from various ministries and departments.
  - A centralized resource for pan-India startup incubators, co-working spaces, labs, and equipment.
  - An interactive space for startups to showcase their products, enabling easy discovery and enquiry.
  - A dedicated space where jobs openings can be posted and jobseekers can apply directly with ease.
- **Incubator Module:** Tools for program management, application management, and resource discovery management.
- **Revamped Portal:** SAYUJ now delivers a significantly enhanced user experience and incorporates advanced functionalities such as Hiring Hub, Product Expo, and an upgraded Incubator Administration Module.
- **Mobile Applications:** Android and iOS mobile applications are available now for Apple and Android users.

SAYUJ URL: <https://sayuj.net/>

## 9.10 Digital India Corporation (DIC)

### 9.10.1 Introduction

Digital India Corporation (DIC) is a not-for-profit company set up & promoted by the Ministry of Electronics and Information Technology (MeitY), Govt. of India. The Company leads & guides in realising the vision, objectives and goals of the Digital India program. It provides strategic support to Ministries / Departments of Centre / States to carry forward the mission of Digital India by way of capacity building for e-Governance projects, promoting best practices, encouraging Public-Private Partnerships (PPP), nurturing innovations and technologies in various domains.

The company encompasses 7 Independent Business Divisions (IBDs) viz. KIDIC Core or Technology Development & Deployment Division (TDDD), NeGD (National e-Governance Division), MyGov, MeitY Startup Hub (MSH), India Semiconductor Mission (ISM), Digital India Bhashini Division (DIBD) and INDIAai.

### 9.10.2 DIC Core or Technology Development & Deployment Division

#### 9.10.2.1 Poshan Tracker

'Poshan Tracker' is a mobile-based application for dynamic identification of stunting, wasting, and under-weight prevalence among children and last-mile tracking of nutrition service delivery by Anganwadi Workers at Anganwadi centres. The application has further been made available to State Officials with the integration of the Supportive Supervision Application and also to beneficiaries through the new Beneficiary interface.

The work undertaken in the area of Process Re-engineering for Digital Transformation:

- A. **Face Capture and Authentication in SNP distribution:** The Poshan Tracker is equipped with the new face capture and authentication feature to ensure that nutritional services are provided to genuine beneficiaries. The implementation of the feature in the Poshan Tracker is a significant step towards ensuring transparency and accountability in the distribution of services, ultimately leading to better nutrition outcomes for the target groups.
- B. **Beneficiary e-KYC** allows Anganwadi Workers (AWW) to complete the e-KYC (electronic Know Your Customer) process for beneficiaries. This feature aims to streamline the verification process and ensure that benefits are delivered efficiently and accurately. It makes it simple for AWWs to verify beneficiaries' identities using electronic methods, ensuring accurate and up-to-date records, faster access to benefits, and a secure and reliable process.
- C. **Keycloak Module** has been implemented to make logging into the Poshan Tracker easier and safer. Keycloak is used to provide a login facility for the application. Roles are managed on Keycloak and based on role user can switch their application behaviour. One can use multiple applications to login via Keycloak with the same user credentials. It makes the app more secure, preventing unauthorized access and keeping user data safe. Additionally, Keycloak has also been implemented in the Supportive Supervision application for State Officials.
- D. **A beneficiary interface** has been provided in the Poshan Tracker application to enable the beneficiaries (users) to register themselves directly on the app.
  - Self-Registration Made Simple: This minimizes the dependency on Anganwadi Workers for manual registration.
  - Approval by Anganwadi Workers: Once a beneficiary registers, the request is sent to the Anganwadi worker, to verify and approve the registration.
  - Access to Personal Information and Services: Beneficiaries can view their service history, which includes information about the child's health and development, like height and weight tracking and details about the nutritional support they received, based on their eligibility or category

- E. Supportive Supervision Application** has been integrated with the Poshan Tracker
- Key features of Supportive Supervision (SS):
- i. Real-Time Monitoring and Support:** Supervisors can access real-time data to provide instant support to AWCs, including:
    - a. AWC open status with timestamps.
    - b. Live access to the AWW dashboard.
    - c. Correction of growth monitoring data.
  - ii. Visit Planning and Scheduling:** State officials can plan and schedule visits with defined objectives and goals, ensuring regular monitoring at pre-defined intervals.
  - iii. Automated Analysis for Improvement:** The application provides automated insights and analysis visit inputs to identify areas for improvement and track quality indicators.
  - iv. Self-Assessment Interface:** dedicated interface for supervisors and officials to conduct self-assessments.
  - v. Performance Review:** State officials can easily review the performance of their immediate subordinates, ensuring accountability across levels.
  - vi. Learning Resources:** Provides easy access to learning capsules and training materials within the application to enhance knowledge and skills.
- F. Protocol for Management of Malnutrition in Children (CMAM):** The CMAM protocol monitors and manages cases of severely malnourished children aged 0-6 years with a focus of identifying, treating, and managing malnourished children both at Anganwadi Centres and in communities. CMAM protocol helps in determining when to refer a malnourished child to Nutritional Rehabilitation Centre (NRC)/ medical facility. The protocol also outlines the steps for identification, management, referral, care level decision-making, nutritional and medical management, and follow-up at the Anganwadi level.
- G. Early Childhood Care and Education (ECCE):** In the endeavor to reposition Anganwadi Centre (AWC) to become the first village output for health, nutrition, and early learning with adequate infrastructure and human resources, appropriate provisions have been brought on to the Poshan Tracker application for ground-level dissemination and implementation of ECCE in every Anganwadi Centre. The purpose of Early Childhood Care and Education (ECCE) is to ensure responsive care, early learning and development which includes physical and motor; language, cognitive, socio-personal, emotional and creative and aesthetic appreciation. It encompasses the inseparable elements of care, health, nutrition, play and early learning within a protective and enabling environment.
- H. Stock Register Module** introduced wherein the Anganwadi worker will be able to keep track of the Supplementary Nutrition Programme stock (Take Home Ration-THR/ Hot Cooked Meal-HCM) required, received and distributed for the month in the Anganwadi Centre (AWC). The new Stock Register module displays the THR and HCM stock requirements based on the beneficiary type in the AWC. The Anganwadi Worker is also provided with an additional feature to enter the THR and HCM Stock received in the AWC date wise. The Stock Register module has inbuilt capability to keep track and update the SNP stock distributed based on the daily THR/CM distribution as part of the AWC daily tracking of beneficiaries.
- I. Family Details:** The register provides an insight into the number of families registered at the Anganwadi Centre, total members in each family, resident Type (Temporary/Permanent) and category wise count of the beneficiaries. It also provides details such as family number (which is unique), name of the family member, their relationship

with the head of the family, gender, marital status, DOB, age, beneficiary type, resident type, religion, and their willingness to avail ICDS services like SNP and PSE.

- J. **Growth Chart:** The Growth Chart section has been enhanced to enable the Anganwadi workers to view a child's complete growth monitoring history. AWW can now access growth records from the child's first monitoring date to the current date.
- K. **Beneficiary Vaccination** module added in the application to enable the Anganwadi Worker to keep track of the vaccination status of the beneficiaries. The module enables the Anganwadi worker to monitor the beneficiaries upcoming vaccinations schedule, vaccinations that are completed and vaccinations that are overdue. The module also provides a vaccination profile of the beneficiary wherein the details of vaccinations due and vaccinations given are listed date wise.
- L. **Heat Map** section has been added to the PT dashboard wherein users can view different indicator statistics on national and state level on India map view. Users based on their login rights are able to select State to check stats based on different colors. Each colour indicates a different range which is mentioned in the legend bar. There are different indicators like AWC open, Morning snacks, Home visits, Growth Monitoring, SNP distributed, SAM, MAM, Wasting children. Stats are also shown in tabular form which can be downloaded in csv format. Users can check/compare the stats on bar graph format. National, State and District average is shown on a bar graph to compare the stats. Users are able to drill down till AWC level in the bar graph. There is a third option which is trend analysis in which users can compare stats of the entire year on a monthly stats basis.
- M. **Growth Trends** shows trends of children's health status in a selected quarter. It showcases health status numbers in tabular form and users can download beneficiary details on district level. Additionally, health status of Stunting, Underweight and Wasting health status are also provided.
- N. **Jan Andolan (Poshan Maah)** under the Poshan Abhiyaan is a people's movement aimed at improving nutritional outcomes through community participation and behavioral change. 8th Poshan Maah serves as a month-long nationwide celebration to spread awareness about nutrition, health, hygiene, and the importance of a balanced diet. All the Activity Logging and Reporting is driven through the Poshan Tracker Web Interface wherein 14 Lac Anganwadi Center participates in month-long events. During Poshan Mah, the Poshan Tracker records details of activities like growth monitoring, nutrition rallies, recipe demos, health camps, and Poshan Vatika plantations, along with participation data of beneficiaries and Anganwadi Centres. It captures children's growth and nutrition data, photographic and geotagged evidence, and details of convergence with departments such as Health and Education. Real-time monitoring tracks outreach and participation, contributing to the national Jan Andolan Dashboard showing cumulative and state-wise performance. Over 6.79 crore activities have been conducted across 776 districts nationwide during Poshan Maah, aligned with the annual themes set by the Ministry of Women and Child Development.
- O. A new Nominee addition ow has been implemented for Pregnant Women, Lactating Mothers and Adolescent Girls. This enhancement allows the beneficiary to add a nominee to receive THR services on their behalf when required. Additionally, THR distribution to nominees is now supported in both online and offline modes, ensuring uninterrupted service delivery even in low-connectivity areas.

### 9.10.2.2 Visvesvaraya PhD Scheme for Electronics & IT

MeitY, with the approval of the Cabinet Committee on Economic Affairs (CCEA) had initiated 'Visvesvaraya PhD Scheme' with the objective to enhance the number of PhDs in Electronics System Design & Manufacturing (ESDM) and IT/IT Enabled Services (IT/ITES) sectors in the country in 2014.

Phase-I of Visvesvaraya PhD Scheme with a budget of ₹466 Crores, initially approved for 9 years from 2014, is extended till Dec 2025.

**Status of Phase-I of the Scheme:**

- 823 Full-time and 189 Part-time PhD candidates completed their PhD
- 19 Full-time and 08 Part-time PhD candidates submitted Thesis
- 32 Full-time and 59 Part-time PhD candidates currently pursuing PhD
- 158 Young Faculty Research Fellowships awarded
- 90 Patents filed and 5750 Research Papers published
- Workshops held for assessment of quality of research

Research has been undertaken under the scheme in emerging research areas viz. Image Processing, DSP, Pattern Recognition, 3D Printing, 5G Communications, AI, Big Data, Blockchain, Distributed Computing, Cyber Security, Green and Sustainable ICT, Quantum Computing/ Communication, Semiconductor Design etc.

**Achievements under Phase-I of the scheme****Some of the Products developed by Visvesvaraya PhD Scholars:**

- UWB Wearable Antenna for Wireless Applications by Ms. Mugdha Kango, Bharati Vidyapeeth
- PTreadX: A Physiology-sensitive Treadmill-based exergaming platform by Dhaval Solanki, IIT Gandhinagar.
- An Automated Multi-user Story-creation and Story-telling platform by Pradeep Raj, IIT Gandhinagar.
- Active Glove ideal for assessment and training of fine hand movements by Chandan Kumar Jha, IIT Gandhinagar.
- FPGA based adaptive digital Beam forming Meta-material antenna by Thogaru Abhishek Reddy, Osmania University

**Some of the Technologies Developed by Visvesvaraya PhD Scholars:**

- Photonic assisted techniques by SRM Institute for generation of:
  - a) Millimeter wave and terahertz signals suitable for 5G/ beyond 5G applications.
  - b) Arbitrary Microwave waveforms suitable for radar and defence applications. Optoelectronic method of assessing cardiovascular pulse wave called Photoplethysmography (PPG) Cardiac Abnormality Detection.
- New image processing framework to find the cell and nuclei variation in low power (40x) magnified microscopic biopsy tissue samples by SRM Institute.
- Tool Chain for Static Analysis of Smart Contracts (Ethereum Platform) Url: <https://youtu.be/fRrp7mvvpMs> by Fajge Akshay Madhukarrao, IIT Patna.
- Point-to-Multi-Point Tracking, NIT Rourkela: A Point-to-Multipoint tracking system for FSO communication that includes coarse tracking and a fine-tuning mechanism based on the IoT cloud information. This system overcomes the pointing errors associated with the FSO communication link <https://www.youtube.com/watch?v=alrLiid2RRo&t=2s>
- Hybrid FSO/RF, NIT Rourkela: A hybrid FSO/RF communication is designed to switch according to the channel conditions. An Image is transmitted using the hybrid FSO/RF communication <https://youtu.be/kEcgsjs-7DY>
- Fog Channel, NIT Rourkela: An indoor fog chamber is designed to evaluate the performance of FSO communication <https://youtu.be/EuET-BLi-B8>
- FSO Transceiver, NIT Rourkela: Transmission through Free space Optics <https://youtu.be/5Szod8M3r6Y>

### Some of the granted Patents of Visvesvaraya PhD Scholars:

- Method of Reducing DOS Attacks using Voice Response in ToT Systems
- System for providing energy management in smart grid environment
- Electrochemical Measurement of Creatinine in Serum
- System for automatic assessment of fluency in spoken language and a method thereof
- Fog based system and method for person identification
- Passive infrared sensor based indoor localization
- Diagnosis of subclinical mastitis in dairy animals
- System and Method for Reduction of Torque Ripple in Double Inverter Fed Wound Rotor Induction Machine
- A Device for Assessment of Seed Pre-Treatments
- Spoof Recognition in an Ear Biometric System
- Image Compression for Transmission
- Drain-Engineered TFET with Fully Suppressed Ambipolarity
- Voltage Keeper Based Robust Flip Flop for Low Power Applications
- Autonomous Navigation Module for Powered Wheelchair
- Smart Barricade System
- A Novel Microfluidic Approach for Bio-Mems Applications
- A completely miniaturized on-chip electron paramagnetic resonance sensor
- Centralized Digital System for PPV and PPC Multimedia Services for Conditional Access System
- Method and System for Secure Group Communication for Dynamic Group
- System for Detecting Type of Sleep Disorders and Method of Operating Thereof

### Some of the Startups by Visvesvaraya PhD Scholars:

- Galanto Innovations by Chandan Kumar Jha, IIT Gandhinagar: <https://www.galantoindia.com/>
- Frazen Technologies Pvt. Ltd. by Thogaru Abhishek Reddy, Osmania University,. <https://www.frazen.in>
- GIGA Innovations Technologies Private Limited in OUTBI by Thogaru Abhishek Reddy, Osmania University: <https://www.gigainnovations.in>
- Evxplorer. Pvt. Ltd by Pranay Kumar Saha, IIT Patna
- EWARN System by K Vinod Kiran, NIT Rourkela: <https://ewarnsystem.com/about.php>

**Visvesvaraya PhD Scheme Phase-II:** Based on assessment of Phase-I, demand from the institutions and role of such scheme in strengthening research eco-system, Phase-II of Visvesvaraya PhD Scheme, was initiated with an outlay of ₹481.93 Crore for 9 years w.e.f. Academic Year 2022-23.

### Salient features of the Scheme are:

- 1000 Full-time PhD seats in the areas of ESDM & IT/ITES.
- Current monthly rates under the scheme: ₹38,750/- (1<sup>st</sup> & 2<sup>nd</sup> Year), then ₹43,750/-.
- 225 Post-Doctoral Fellowships.

- One time support for 250 Candidates (50 candidates/year) for 6 months Visit to Labs Abroad.
- Support for International Conference up to ₹1.5 Lakh.
- Contingency Research Grant @ ₹1.20 Lakh/year per Full Time PhD.
- 150 Part-time PhD seats & 50 “Young Faculty Research Fellowships” to be awarded.
- One time award of ₹3.0 Lakh for Part Time PhD candidates after completion of PhD.
- YFRF Fellowship & Contingency Grant @ ₹20,000/- per month & ₹5 Lakh/year respectively upto 5 years.

**Status of Phase-II of the Scheme:**

- 1000 Full time and 153 Part time PhD seats allotted to 155 and 112 institutions, respectively.
- 774 Full-time and 57 Part-time enrolments reported in 131 and 33 institutions, respectively
- 125 PDF seats allotted to 114 institutions
- 76 PDF enrolments reported in 70 institutions
- 11 Young Faculty Research Fellowships awarded
- Two workshops for review of research work of PhD scholars held at IIT Mandi in Sep 2024 and at IIT Indore in Sep 2025

**9.10.2.3 DIKSHA (Digital Infrastructure for Knowledge Sharing)**

DIKSHA (<https://diksha.gov.in/>) is a national digital platform for school education, developed by NCERT under the Ministry of Education, Government of India. The platform supports learners and teachers across the country and caters to NCERT, CBSE, and State/UT curricula in over 135 languages. DIKSHA is leveraged for school education, foundational learning, teacher capacity building, and inclusive education for underserved and differently-abled learners.

The platform is built on open-source technologies and hosted on cloud infrastructure, with Digital India Corporation (DIC) responsible for technical administration and cloud operations.

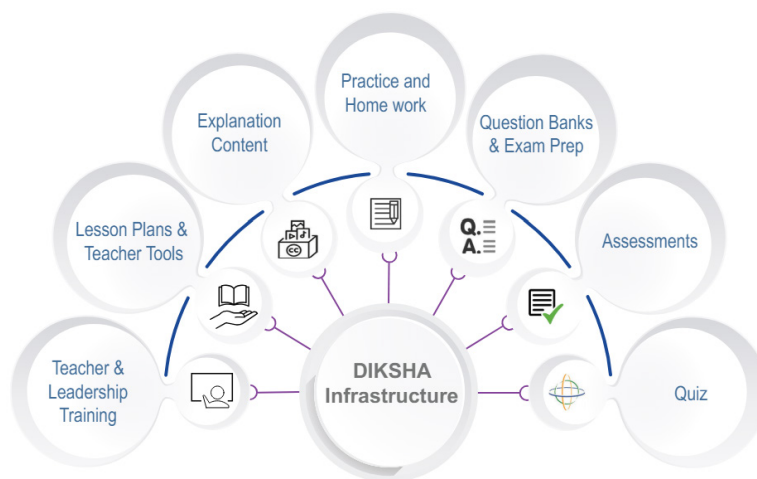

**Key Solutions / Use-cases of DIKSHA**

DIKSHA follows a modular architecture and continues to evolve based on ecosystem needs. Major use-cases include:

- **Energized Textbooks (ETBs):** Over 7,513 ETBs are available, providing curriculum-aligned digital learning resources across boards, grades, subjects, and languages.
- **Online Courses and Digital Credentials:** DIKSHA hosts large-scale teacher and student training programs, including NISHTHA. The platform has recorded over 18.41 crore enrolments and issued more than 12.65 crore digitally verifiable certificates.

- **Question Bank and Assessment Tools:** Enables creation and curation of curriculum-linked questions for worksheets, assessments, courses, and quizzes.
- **Content Sourcing and Authoring (VidyaDaan):** Supports sourcing, curation, and creation of high-quality digital content in multiple formats and languages through a structured review process.
- **Quiz and Engagement Tools:** Facilitates national and state-level quizzes and competitions, with recognition through digital credentials.
- **Content Consumption and Access:** Provides access to over 3.62 lakh digital resources across devices, in online and offline modes, including guest and registered user access.
- **Data, AI and Support Tools:** Offers dashboards and reports for monitoring program outcomes, along with an AI-based chatbot (Ask DIKSHA) for learner support.

The impact of DIKSHA's offerings is evident in the numbers, with over 565 Crores learning sessions facilitated on the platform till date.

#### 9.10.2.4 DIKSHA - PRASHAST (Pre-Assement Holistic Screening Tool)

The development of DIKSHA - PRASHAST was germinated in the Department of Education of Groups with Special Needs (DEGSN), NCERT to facilitate regular teachers and Special Educators to screen and tentatively categorize the 21 disability conditions at the school level, so that they can be referred for further assessment during assessment and certification camps.

The tool comprises two parts:

**Part-1:** Used by regular teachers for preliminary screening of students.

**Part-2:** Used by special educators to validate observations and support referrals to assessment and certification camps.

#### Overview and Key features

- Facilitates early identification and referral for disabilities
- Addresses gaps arising from low awareness and non-visible disabilities
- Available on Android and iOS (web version under UAT)
- Enables screening of all students to support timely interventions

#### PRASHAST: Key Highlights and Reach:

- **Stakeholder Registration:** Over 1.14 lakh users, including School Heads, Teachers, and Special Educators, are registered on the PRASHAST 2.0 platform, creating a nationwide network for early disability identification.
- **Screening Part-1:** Teachers have successfully completed 5.19 lakh+ preliminary screenings. This stage uses observation-based checklists to identify behavioral manifestations of the 21 disabilities recognized under the RPwD Act, 2016.
- **Screening Part-2:** Special Educators have completed 17,277 in-depth validations. This critical step verifies preliminary findings and facilitates the formal referral process for diagnostic assessment and disability certification.

## PRASHAST: A Two-Part Screening Process

	Screening Part 1	Screening Part 2
<b>Who uses it?</b>	Regular class teachers in schools	Utilized by special educators
<b>What is its purpose?</b>	To conduct a preliminary, first-level screening of all students in a class	To validate the findings from PRASHAST Part-1 and tentatively categorize specific disability conditions
<b>How it works?</b>	Teachers observe students for 2 weeks or more across various contexts (academic, social, behavioral, mobility) and tick objective-type items in the checklist based on observed behaviors.	<ul style="list-style-type: none"> <li>Decodes Part-1 observations using a dedicated table.</li> <li>Involves detailed behavioural observations of the student over a considerable period (minimum 15 days)</li> </ul>
<b>Content</b>	Contains 63 items designed to capture observable characteristics related to various disabilities, structured as a simple "tick (✓)" response.	Contains individual checklist for individual disability including Starred Behaviours and red flags
<b>Outcome</b>	After completing Part-1 more detailed screening is done by special educators using Part-2	Aims to narrow down to possible disability conditions, leading to parent consent for further referral to assessment and certification camps

### 9.10.2.5 LokOS: Digitizing Self-Help Groups (SHGs) in India

The Deendayal Antyodaya Yojana - National Rural Livelihoods Mission (DAY-NRLM), under the Ministry of Rural Development, Government of India, aims to eradicate rural poverty by empowering SHGs and strengthening livelihoods, covering over 10 crore+ SHG members across 90 lakh+ SHGs nationwide. To support large-scale operations and MIS needs, NRLM introduced LokOS, a community-centric digital platform built on a microservices-based, federated architecture that digitizes SHG and CBO transactions, improves data accuracy at the source, and strengthens the central NRLM MIS through integrated applications and modules. The list of modules are as follows:-

- Profile Module
- Transaction Module
- Digital Ajeevika Register
- Village Prosperity and Resilience Plan
- Producers Group Portal
- Training Module
- Saksham, e-FMAS & FDM applications
- Project Activities Monitoring & Tracking Module
- Centralized User Management Module
- Cadre Training & Management
- Sarathi (Ultra Poor) & Equal

#### Impact and Reach

LokOS has a wide impact and reach, supporting 10.13 crore SHG members, 91.76 lakh Self-Help Groups, 5.54 lakh Village Organizations, and around 34,000 Cluster Level Federations across the country. It also enables

real-time tracking of the Lakhpati Didi Initiative, with 4.06 crore potential Lakhpati Didis identified and 14.05 crore entries captured in the Digital Aajeevika Register. By improving transparency, operational efficiency, and digital access, LokOS is playing a key role in transforming rural livelihoods through real-time monitoring and data-driven decision-making.

### 9.10.2.6 Kisan Sarathi 2.0 - Enhancement, Operations, Maintenance and Support.

The project is being implemented in partnership with the Indian Council of Agricultural Research (ICAR) to provide location-specific, demand-based Tele-Agriculture Advisories to farmers in their local languages through Krishi Vigyan Kendras (KVKs). During the period, 741+ Krishi Vigyan Kendras (KVKs) / DAATTCs were onboarded on the platform. A total of 548 KVK experts and 3,058+ Subject Matter Experts from all States and Union Territories were enrolled. 32.54+ lakh new farmers were registered during the period, taking the cumulative farmer registrations to 280.53+ lakh. The platform handled 48,165+ farmer calls during the period, with cumulative calls reaching 2,90,044+. Additionally, 16.34+ crore messages were disseminated during the period, increasing the cumulative message count to 70.50+ crore. The IVRS was further enhanced to deliver domain-specific advisories in 13 languages, based on the availability of experts at KVKs.

#### Enhancement : Kisan Sarathi Applications ([kisansarathi.in](https://kisansarathi.in))

**Kisan Sarathi Farmer App (iOS and Android):** Released in August 2025 (Beta). Key features include video consultancy, webinar, farmer registration and profile management, multimedia query raising and tracking, expert advisories, call-to-expert facility, access to government schemes, weather information, multilingual support in 13 regional languages through Bhashini, and technical support.

**Kisan Sarathi Expert App:** Released in July 2025 (Beta). Features include video consultancy, farmer and query management, individual and bulk advisory management, call management, chatbot integration, multilingual translation and transliteration through Bhashini, and technical support.

**KS Kosh / Agricultural Advisory Management System (AAMS):** KS Kosh was released for ICAR Scientists in September 2025. The Content Creator module enables location-specific advisory creation, including Packages of Practices (PoP). The Content Approver module supports content review, feedback, and publication.



**KISAN SARATHI**  
Powered by IITK

**KISAN SARATHI**  
Powered by IITK

## Kisan Sarathi – Your Digital Farming Assistant

*Ask agriculture-related queries anytime*

- Track your queries & download advisory prescriptions
- Access multimedia advisories in your local language
- Ask your farm questions by sending photos, voice, or videos
- Check real-time weather updates for your village

## KS EXPERT Guidance for Every Farmer

- Provide expert advisories directly to farmers
- Manage & respond to queries efficiently
- Chatbot integration for instant support
- Conveniently deliver multimedia advisories to farmers
- Dedicated technical support for smooth operations

**System Integrations:** Integration with the Kisan Call Center (KCC) has been completed, and pilot testing is currently underway in Uttar Pradesh and West Bengal as of July 2025. Integration with Common Service Centers (CSC) has also been completed, with internal testing presently in progress. Further, integration with the India Meteorological Department (IMD) has been completed to enable access to real-time weather data. In addition, integration with the myScheme platform has been completed to facilitate personalized identification and sorting of Central and State agriculture schemes based on individual farmer profiles.

### 9.10.2.7 NCW 24x7 Women Helpline

With the objective of facilitating women victims and providing them with psychological support, the National Commission for Women (NCW) initiated a dedicated helpline. DIC has been providing technical support to NCW for the development, maintenance and hosting of the helpline platform, which is built on DIC's IIDS platform. For this purpose, a dedicated helpline number 14490 has been made operational.

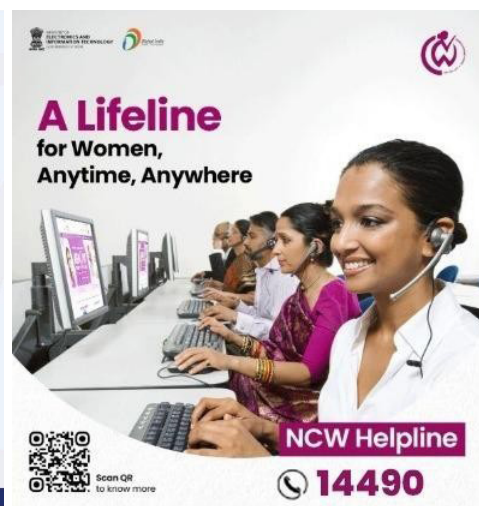

During the period, a total of 1,87,827 calls were received and made through the NCW Helpline platform, taking the cumulative call volume to 6,23,232. Concurrently, the application domain was migrated to a subdomain of ncw.gov.in. New system reports and a dedicated call analytics page were developed and integrated. Support tickets were addressed on a priority basis, and continuous technical support and maintenance were provided to ensure the smooth and uninterrupted functioning of the application.

### 9.10.2.8 NCW - Her Legal Guide App

“NCW – Her Legal Guide” is a mobile application developed by Digital India Corporation (DIC) for the National Commission for Women (NCW), focusing on various rights and statutes pertaining to women in India. The application is available on Android and iOS platforms through UMANG, with content provided in Hindi and English. During the period, technical support and server maintenance were provided for the application. In addition, various helpline numbers were incorporated into the application to enhance user accessibility and support.

### 9.10.2.9 NCW Website

The NCW website has been revamped to address security vulnerabilities and upgrade outdated software platforms. The revamped website was successfully launched on 11 March 2025.

### 9.10.2.10 MY Bharat (Mera Yuva Bharat): Empowering India's Youth

MY Bharat is an initiative of the Department of Youth Affairs, Ministry of Youth Affairs and Sports, with the digital platform designed, developed, and managed by the Digital India Corporation (DIC). Conceived as a technology-driven, youth-centric national ecosystem, MY Bharat enables young Indians to engage in developmental and volunteering opportunities, mentorship, and community-led initiatives. The platform entered its next phase with the signing of the MoU for MY Bharat 2.0 on 30 June 2025.

The platform is available in 22 regional languages and through a mobile application, offering features such as Experiential Learning Programmes, Volunteer Opportunities, Design for Bharat, Hack for Social Cause, quizzes, mentorship, CV

Builder, and an AI-powered chatbot integrated across web and WhatsApp. Integrated with NCS and CSCs, MY Bharat ensures inclusive last-mile outreach.

Since launch, MY Bharat has registered over 2 crore users, adding 41.35 lakh new registrations during 2025, with 22.33 K+ ELPs and 1.35 lakh+ Volunteer Opportunities published. The platform achieved 21.5+ million digital impressions across social media and messaging channels, significantly amplifying national youth initiatives such as Viksit Bharat Young Leaders Dialogue, Nasha Mukta Bharat, Viksit Bharat Youth Parliament, National Unity March, etc, thus strengthening nationwide engagement



#### 9.10.2.11 E-SARAS (<https://www.esaras.in/>)

Under the National Rural Livelihoods Mission (NRLM) of the Ministry of Rural Development, the eSaras digital marketplace has been developed to support rural artisans and Self Help Groups (SHGs). The platform, developed and technically supported by Digital India Corporation (DIC) and operated by FDRVC. It integrates Razorpay for secure digital payments and Shiprocket for pan-India logistics, with a dedicated toll-free support number (1800-102-0988).

The multi-vendor eSaras platform, built using LokOS APIs, went live on 24 May 2025 and was merged with LokOS w.e.f. 24 August 2025. The platform is integrated with the UMANG app and supports multiple Indian languages through the Bhashini API. Continuous technical support, training, and system monitoring are being provided to ensure smooth operations.



#### 9.10.2.12 India Handmade ([www.indiahandmade.com](http://www.indiahandmade.com))

IndiaHandmade (<https://www.indiahandmade.com/>) is an e-commerce portal designed and developed by the Digital India Corporation (DIC) to empower artisans and weavers by enabling direct promotion and sale of authentic handloom

and handicraft products, thereby eliminating intermediaries and ensuring fair remuneration for the Ministry of Textiles. Sellers are supported through well-documented systems and processes, with on-ground assistance provided by Weavers Service Centres (WSCs) and Handicraft Service Centres (HSCs) for awareness generation, onboarding, product listing, and order processing. A dedicated customer care team addresses buyer and seller queries through a toll-free helpline (1800-121-6216). The platform offers a wide range of products, including handloom clothing, furnishings, décor items, furniture, paintings, sculptures, art jewellery, accessories, and more, with free shipping on all orders.

### Key Activities Undertaken During the Year

During the year, Digital India Corporation undertook development, maintenance, and technical support of the IndiaHandmade web portal and mobile applications. More than 2,886 sellers were onboarded, with 17,500+ handmade products listed on the platform. Over 2,000 customer orders covering 3,200 products were successfully processed. 100+ training and orientation sessions were conducted to support sellers in account management, product listing, order processing, and reporting. Promotional campaigns



were carried out through social media, WhatsApp, print media, and participation in various state-level fairs and melas. The platform was enhanced with WhatsApp Bot integration for sellers and buyers, Power BI dashboards for advanced analytics, and ONDC integration, which was made live in beta production. Additionally, the Handloom Week Sale (7–15 August 2025) was successfully organized, achieving sales of ₹7.7 lakh from 257 orders covering 502 products, with the highest-ever single-day sales of ₹2.76 lakh recorded on the final day of the campaign.

### 9.10.2.13 NHAIDATALAKE 3.0

<https://datalake.digitalindiaincorporation.in/>

**About NHAID:** National Highways Authority of India (NHAID) was set up by an act of the Parliament, NHAID Act, 1988 to provide for the constitution of an Authority for the development, maintenance and management of national highways and for matter connected therewith or incidental thereto”. It has been entrusted with the National Highways Development Project (NHDP), which along with other minor projects, has vested in it 55,000+ kms of National Highways for development, maintenance and management.

#### What is NHAID Datalake 3.0 ?

NHAID Data Lake 3.0 is an advanced, in-house digital platform developed by National Highways Authority of India (NHAID) for managing its highway project portfolio. It is a complete technological overhaul of the earlier Data Lake system, built on modern and scalable technologies to address future requirements of highway project management.

The platform delivers end-to-end digital project lifecycle management, covering project initiation, DPR preparation, procurement, pre-construction approvals, construction and maintenance monitoring, tolling, finance, and legal workflows. Key features include a GIS-first architecture, Aadhaar-based authentication, role-based access control, custom dashboards, contract-based monitoring, and an AI-enabled chatbot.

NHAI Data Lake 3.0 is designed for all NHAI stakeholders and is envisioned as a scalable highway infrastructure management solution that can be extended to other road authorities such as Ministry of Road Transport and Highways (MoRTH) and National Highways & Infrastructure Development Corporation Limited (NHIDCL)..

### **Engagement of Digital India Corporation:**

A Memorandum of Understanding (MoU) between NHAI and Digital India Corporation was signed on 28 November 2023 for the development of NHAI Data Lake 3.0. The estimated cost for the first year of implementation is ₹30.84 crore, covering development and deployment for a period.

### **Product Roadmap:**

The Product Roadmap has been planned to be delivered in three phases. In the first Phase the modules of NHAI One app and Core modules are planned. In Phase 2 modules for Maintenance, Finance stage of project are planned and in Phase 2 construction and pre-construction are planned.

### **Phase 1 Launch:**

The Phase 1 of NHAI Datalake 3.0 has been launched across India across users within NHAI across Headquarters, 25 Regional Offices, 200+ Project Implementation Units in cities and contractors, authority engineers, auditors, user fee agencies. Modules available for use are

- Login and Registration - Aadhaar based authentication using Digilocker & mobile OTP login
- Access Based Control - Role based access of each user and data shown as per the jurisdiction of the user.
- Unique Contract Code - Contract creation workflow that creates a unique contract code. An interactive experience of the GIS layer provided to the NHAI users to choose the exact extent of the project work
- Attendance Management System - Authority engineers on site to mark attendance with their geo tagged data and a real time check of the location with the alignment of the project. Along with geofencing, face authentication check also put in place.
- Road Maintenance - Allows users to raise defects and conduct joint inspections on the site and log the defect with geotagged photos and meta data
- Request for Inspections - A critical workflow for the monitoring of construction progress is made available for contractors and authority engineers such that request for inspection for every work is raised on app and then approved or rejected to mark the progress of the work
- Road Safety Audit - Allows Safety Consultants to conduct audit on mobile and log their observations against any project and then these defects are forwarded to contractors for compliance by competent authorities.
- Toilet Maintenance - To maintain the user experience of citizens of toilet blocks near highways, a monitoring mechanism has been implemented such that the block supervisors are supposed to submit inspections on a daily basis and using AI based algorithm the pictures of toilets are marked as clean or unclean
- Helpdesk - A help center has been created such that it can self serve the end users. A chatbot has been implemented that is trained on SOPs and FAQs of the platform.
- Team Structure - Allow PDs to add team structure as per the contract in a specific project. It allows users to create a composition by adding designations and then adding members against those designations.

Phase 1 was launched starting from Delhi and Jaipur Regional Office's on 22 July 2025 and rollout was completed across India within a period of 1.5 months.

### Phase 2 and Remaining Modules:

A list of modules has been prioritized from the remaining modules of Datalake 2.0. Requirement gathering for Bridge Structure Inspection, Road Closure, User Fee Agency Onboarding, Toll Master creation, Critical Correspondence, Document Repository, Payment to AE, Digitize Schedule H have been completed and designs are to be completed by end of october. The development of the BRICS is completed and Road Closure is in progress.

A tentative list of the remaining modules of Datalake 3.0 has been finalized as below. Month 1 is the current month.

<b>Month 1</b>	<ul style="list-style-type: none"> <li>• Onboarding of User Fee Collection Agency</li> <li>• Payment to AE/IE</li> <li>• Critical correspondences (cure period, suspension, show cause, notice of intention to terminate, termination, debarment/blacklisting)</li> <li>• Document Repository</li> <li>• Digitization of Schedule H</li> </ul>
<b>Month 2</b>	<ul style="list-style-type: none"> <li>• Financial Progress</li> <li>• Issuance of NCR</li> <li>• Onboarding O&amp;M Agency and other Agencies</li> <li>• Rectification of Blackspots</li> <li>• Road Accident Monitoring &amp; Reduction API</li> <li>• Toll Collection API</li> <li>• Toll asset management API</li> <li>• Drone Video Report</li> <li>• NSV Surveys/Priority Maintenance</li> <li>• Digital O &amp;M MPR</li> <li>• Payment for Contractor/Concessionaire during maintenance period</li> </ul>
<b>Month 3</b>	<ul style="list-style-type: none"> <li>• Onboarding of DPR Consultant</li> <li>• LoA Issuance to DPR Consultant</li> <li>• Appointment / DPR Personnel</li> <li>• DPR Preparation, Submission and Review</li> <li>• LAC-1 (Alignment Approval)</li> <li>• LAC- 2 (Plan approval)</li> <li>• Monitoring - 3A status - API</li> <li>• Monitoring - 3D status - API</li> <li>• 3G Declaration of Award - API</li> <li>• 3H Payment for Land Acquisition - API</li> <li>• Applicable Permits (Contractors/ NHAI)</li> <li>• Utility Shifting</li> <li>• Payment for Contractor/Concessionaire during construction</li> </ul>

<b>Month 4</b>	<ul style="list-style-type: none"> <li>• PATSC / IAC Approval</li> <li>• SFC Approval</li> <li>• EFC Approval</li> <li>• PPPAC Approval</li> <li>• Project Sanction</li> <li>• Bid Document Preparation (CO)</li> <li>• Bid Invitation (CO)</li> <li>• Bid Evaluation (CO)</li> <li>• LoA Issuance to Contractor</li> <li>• Agreement-Contractor/ Concessionaire</li> <li>• Onboarding of Consultant (AE/IE/SC)</li> <li>• LOA Issuance to AE/IE/SC &amp; Agreement signing</li> <li>• Joint Memorandum of Handing over of Land or providing ROW</li> <li>• Financial Closure( in PPP Projects)</li> <li>• Issue of Appointment Date</li> </ul>
<b>Month 5</b>	<ul style="list-style-type: none"> <li>• Design and Drwaing Submission Revision</li> <li>• Submission and Approval of Work Programme</li> <li>• Contractor manpower Deployment</li> <li>• Equipment Deployment</li> <li>• Construction Methodology</li> <li>• Critical Issues and Actions</li> <li>• Strip Chart (Chainagewise Progress)</li> <li>• Quality Assurance Plan</li> <li>• Quality Inspection by SRDQ</li> <li>• Termination of Contract</li> <li>• Digital MPR (Contractors / Concessionaire)</li> <li>• Quality Inspection by PD / RO / GM</li> </ul>
<b>Month 6</b>	<ul style="list-style-type: none"> <li>• EoT</li> <li>• CoS/ Withdrawl of Work</li> <li>• Surplus Land Monitoring</li> <li>• Blacklisting of Agencies and Individuals</li> <li>• PCC / PCOD</li> <li>• Punchlist Monitoring</li> <li>• CC / COD</li> </ul>

### 9.10.2.14 MANAS- National Narcotics Helpline

MANAS – National Narcotics Helpline (<https://www.ncbmanas.gov.in>) is a national initiative of Narcotics Control Bureau (NCB), Ministry of Home Affairs, to provide a comprehensive narcotics digital helpline platform designed, developed and managed by. MANAS operates as a 24x7 multi-channel platform, enabling citizens to anonymously report or seek assistance on drug-related issues through a toll-free number (1933), web portal, email, and the UMANG mobile application.

The helpline supports drug addicts, informers, and citizens by offering round-the-clock assistance, awareness on government schemes and support services, and integrated multi-sectoral support, including counselling and rehabilitation, through a single-window mechanism. Operated from NCB Headquarters, New Delhi, MANAS is integrated with 30 zonal units and 36 Anti-Narcotics Task Forces (ANTFs) across the country..

During the period, the MANAS – National Narcotics Helpline was significantly strengthened through streamlined CRM workflows across L0–L6, redesigned IVRS for improved call connectivity, and enhanced operational capacity with additional manpower and regional language support. Monitoring and compliance were reinforced through real-time dashboards, access controls, and audit mechanisms. Key system enhancements included CRM attachments, an awareness section on the portal, improved informer management, ticket reversion and re-submission, call-ticket forwarding, and structured call assignment and callbacks.

#### Four Communication Channels for the MANAS Helpline:



#### Academic Bank of Credits (ABC) and Automated Permanent Academic Account Registry (APAAR)

The Academic Bank of Credits (ABC) and the Automated Permanent Academic Account Registry (APAAR) are flagship digital initiatives of the Ministry of Education (MoE) that operationalize key reforms envisaged under the National Education Policy (NEP) 2020. Together, they establish a unified digital framework for student identity, academic credit accumulation, transfer, and verification across India’s education ecosystem.

ABC enables secure storage and portability of academic credits, while APAAR provides every learner with a unique, lifelong Academic ID (One Nation, One Student ID). The Digital India Corporation (DIC), under the Ministry of Electronics and Information Technology (MeitY), serves as the Technical Implementation Agency, ensuring scalable, secure, and interoperable platforms aligned with national digital public infrastructure.

#### NEP 2020 mandates a shift towards:

- Flexible learning pathways and multiple entry–exit options
- Credit-based, multidisciplinary education
- Integration of academic, vocational, and skill-based learning
- Recognition of prior learning and lifelong education

#### Academic Bank of Credits (ABC)

The Academic Bank of Credits serves as a centralised digital repository for academic credits earned from recognised Higher Education Institutions (HEIs), approved online platforms, and skill development programs.

**Key Objectives:**

- Secure accumulation and management of academic credits
- Seamless credit transfer and redemption across institutions
- Support for multiple entry and exit options in degree programs
- Verified credits through integration with DigiLocker and the National Academic Depository (NAD)
- Defined validity period for credits, enabling flexible completion of qualifications

**Automated Permanent Academic Account Registry (APAAR)**

APAAR provides a unique 12-digit lifelong Academic ID to each learner, covering education from pre-primary to higher education.

**Key Objectives:**

- Unified academic identity across all stages of education
- Centralised digital record of certificates, marksheets, scholarships, and achievements
- Secure access and storage through integration with DigiLocker
- Digitized migration and transfer records enabling inter-state and inter-institutional mobility

APAAR ensures authenticity, transparency, and ease of verification of academic records for students, institutions, and employers.

Total APAAR ID created & verified	APAAR IDs Seeded with Credits	Educational Records Mapped with Credits and APAAR ID	Awarding Institutions Registered
24.38 Cr	2.21 Cr	7.20 Cr	2774

**Salient Features**

In pursuance of the objectives outlined under the National Education Policy (NEP) 2020, and in furtherance of the directives of the Ministry of Education, the Academic Bank of Credits (ABC) has been instituted with the following key features:

- **Provision for Multiple Entry and Exit:**

The system enables multiple entries and exits in the academic lifecycle of students, thereby offering enhanced flexibility and lifelong learning opportunities.

- **Institutional Authentication of Credits:**

Only duly recognised and verified academic institutions shall be permitted to upload the credit records of students onto the ABC platform, thereby ensuring authenticity, integrity and credibility of the academic data.

- **Digital-First and Online Mode of Operation:**

The Academic Bank of Credits shall operate in a fully online and digital mode, providing a centralised, secure and user-friendly system for credit management and redemption.

- **Freedom of Course Selection:**

Students shall be empowered to select courses or combinations of courses that align with their aptitude, interests and pursuit of knowledge, as against the earlier system of rigidly prescribed degree structures.

- **Flexibility in Degree Attainment:**

The framework shall allow students to tailor their degrees and make appropriate modifications, specialisations or combinations of subjects, rather than being confined to the courses mandated by a single university or autonomous institution.

- **Integration with National Schemes:**

Courses pursued by students through national-level online education schemes such as SWAYAM, NPTEL, Virtual Labs (V-Lab) and other specified universities/institutions shall be duly recognised and mapped under the ABC for credit accumulation, transfer and redemption.

Digital Educational Records	School & Technical Education	Higher Education	Skill Education
103 Cr	70.87 Cr	23.39 Cr	6.50 Cr

**Institutional Engagement:**

As of December 2025, ABC boasts a robust network with 2,652 registered institutions, comprising central universities, State Universities, deemed-to-be universities, Private Universities, Institutions of National Importance, Autonomous Colleges, School boards, Technical Boards, and various other educational bodies. The details are as follows:

Category	Total Awarding Institutions (Approx.)	Institutions Enrolled on ABC	Students/Learners APAAR IDs created
Central University	57	55	4795201
Deemed University	150	131	1382207
Private University	546	504	3285858
State University	514	475	32323521
Autonomous College	1727	1066	3056634
Institutions of National Importance (IIT, IIM, NIT, IIIT, etc.)	165	145	366976
Skill Institute	105	88	15565956
Other Institutions (Standalone, Councils, Technical & Examination Boards, etc.)		320	29774963
School Education (UDISE+)			153263560
<b>Grand Total</b>	<b>3264</b>	<b>2,784</b>	<b>24,38,14,606</b>

**Key Highlights:.**

- 9 Crore records were verified through API Setu & DigiLocker.
- 5.50 Crore results were accessed on the result day, with 1.81 Crore active users
- 3 Crore credit records have been successfully seeded with APAAR IDs this year.
- 1.84 Crore APAAR IDs have been seeded with credits.
- 2 Lac records are processed in a single day
- Real-time API and ERP integrations enable efficient processes for result declaration, eKYC, and credit mapping.
- Seamless integration with national platforms like DigiLocker, E-Samarth ERP, NSP, NTA, Skill India Digital, and others has enhanced transparency and efficiency.

- APAAR IDs can now be created using Driving Licenses and PAN cards. The creation process is available through multiple convenient channels: DigiLocker, Umang, the ABC portal directly by the student, Common Service Centres (CSC) with assistance, and via API/Bulk module through academic institutions. For minor students, APAAR IDs can be generated with parental consent through school administrations.
- Support services include a ticketing system, video conferencing for institutions, and a dedicated call centre (1800-889-3511) for student inquiries, approx 400-450 Calls per day and 350 Tickets per day, along with updated knowledge and resource pages.

#### Way Forward:

- Strengthening two-way integration with key schemes and platforms such as NSP, NTA, and Samarth to ensure seamless data exchange and process optimization.
- APAAR ID generation for foreign students
- Developed credit transfer guidelines and module
- Enhancing the ABC student account dashboard to align with National Credit Framework (NCrF) standards, ensuring comprehensive and standardized record-keeping.
- Expanding the use of APAAR ID for eKYC in critical processes, including admissions, entrance tests, counselling, examinations, and scholarship applications.
- Facilitating document verification through APAAR ID for recruitment, employment, apprenticeships, and admissions to streamline verification processes.
- Conducting awareness workshops at both state and institutional levels to promote the adoption and understanding of ABC and APAAR initiatives.
- Establishing ABC as a one of a parameter in accreditation evaluations
- Develop advanced data analytics tools to provide institutions and policymakers with actionable insights into academic trends, credit utilization, and student progress.
- Link APAAR IDs with skill certifications from recognized organizations to bridge the gap between formal education and vocational training.

#### Vande Mataram 150

Vande Mataram 150 is an initiative of the Ministry of Culture to commemorate 150 years of the national song “Vande Mataram”, implemented through a dedicated digital portal designed and developed by the Digital India Corporation (DIC). The portal showcases the song’s historical evolution, cultural significance, and national impact through multimedia content, archival resources, and participatory digital experiences. Key features include karaoke-based video recording with digital certificates, event creation for States, Ministries, educational institutions, and organizations, a structured moderation workflow, real-time dashboards, and multilingual access in 23 languages.

The Vande Mataram 150 portal enables citizens to record karaoke-based video renditions and receive digital participation certificates, create events for States, Ministries, colleges, schools, institutions, and organizations, and upload content through a structured moderation workflow. The platform features a dynamic dashboard with real-time analytics, an interactive home page comprising sections on About, History, Video Gallery, Event Gallery, and Downloads, and provides multilingual access in 23 languages.

The initiative witnessed extensive nationwide participation, with approximately 1.65 crore participants, 1.47 lakh renditions, and 46,376 events conducted across 36 States and Union Territories. Events were organized by 52 Ministries, 672 colleges, and 13,098 schools, reflecting strong engagement from government institutions, educational bodies, and citizens across the country.

Government of India
Skip to Main Content | A- A+ | Toll Free: 10505 | Email: vandemataram0150@gmail.com

150 Years of Vande Mataram
Home About Gallery History Republic Day Events Downloads Dashboard

Ministry of Culture  
Government of India

A Spiritual & Patriotic Ode to Mother India

# VANDE MATARAM

Commemoration of 150 Years of National Song

Be a part of this momentous occasion and upload your rendition of 'Vande Mataram'

vandemataram150.in

"If patriotism and love for Mother India are feelings beyond words, then *Vande Mataram* is the song that gives a concrete expression to those feelings."

**-Narendra Modi**  
Prime Minister

1,65,87,455

Renditions of Vande Mataram

Step 1

Enter your Details

Step 2

Record Your Video

Step 3

Upload the Video

Step 4

Download Certificate

### 9.10.2.15 Data Processing, Interpretation, and Integration Centre (DPIIC)

#### About Project:

The Data Processing, Interpretation and Integration Centre (DPIIC) will be established as a National-level geoscientific hub under the Geological Survey of India at RSAS, Bengaluru to accelerate the discovery of mineral deposits, including concealed and deep-seated mineralization, using computer-aided classical and advanced AI/ML/DL methodologies. It will serve as a facility to transform multidisciplinary geoscientific data into actionable insights for efficient mineral exploration and decision-making.

#### Key Features:

- Transform geoscientific data into actionable insights for identifying new potential mineral zones.
- Leverage conventional & AI/ML/DL algorithms and multivariate analysis to accelerate mineral discovery in the country.
- Develop a unified, interoperable geospatial data platform compliant with NGDR and GSI Compliance Standards.
- Facilitate stakeholder collaboration and data-driven decision-making for effective exploration strategies through the provision of Physical and Virtual Data Room Service.
- Strengthen R&D and capacity building in mineral exploration technologies.
- Training Geo-scientists to enhance skills and adoption of advanced AI/ML/DL and computer-aided classical methods through in-house and i-GoT platform.

**Progress of Phase-I (October-2024 to December-2025)**

- Engagement of PMU: DIC was formally engaged as the Project Management Unit (PMU) for DPIIC through execution of a Memorandum of Agreement (MoA). The scope includes deployment of expert resources, support for preparation of the Expression of Interest (Eol) and Request for Proposal (RFP), vendor evaluation, and provision of project management advisory services.
- Publication of Eol: The DPIIC Eol, containing details on project overview, indicative scope of work, data architecture expectations, cloud infrastructure, and processing requirements, was published on the CPP Portal in January 2025.
- Eol Opening and Evaluation: Eol bids were opened in May 2025, and the evaluation process was completed in December 2025.
- Submission of DPR: The Detailed Project Report (DPR) for DPIIC was submitted to the Ministry of Mines in November 2025 for approval.



# 10

## CHAPTER

# Other Matters

### 10.1 Promotion of Hindi and implementation of the Official Language Policy:

#### 10.1.1 Introduction

The Ministry of Electronics and Information Technology ensures proper compliance of all the important provisions of the Official Languages Act, 1963 and the rules and regulations of the Official Languages Rules, 1976. In addition, appropriate guidance is also provided, time to time, to ensure compliance of these rules in the offices under the administrative control of the Ministry .

#### 10.1.2 Hindi Advisory Committee

The Hindi Advisory Committee is a high-level committee charged with monitoring the implementation of official language policies. This committee has recently been reconstituted under the chairmanship of the Honorable Minister of Electronics and Information Technology. The committee includes linguists, retired officials involved in the implementation of the official language policy, as well as technical experts. The first meeting of the reconstituted committee is proposed to be held shortly.

#### 10.1.3 Official Language Implementation Committee

The Official Language Implementation Committee in the Ministry has been reconstituted under the chairmanship of Scientist 'G' and Group Head, a Joint Secretary level officer. The meeting of the Official Language Implementation Committee is held every quarter to discuss various issues related to the implementation of the Official Language Policy in the Ministry and the achievements made towards achieving the set targets, the challenges faced and their appropriate solutions. Apart from this, quarterly progress reports of various sections of the Ministry and attached/ subordinate offices and statutory/autonomous bodies are also reviewed.

#### 10.1.4 Official Language Inspection by the Ministry

According to the Annual Programme 2024-25 issued by the Department of Official Language, Ministry of Home Affairs, ministries/departments are required to conduct official language inspections of at least 30% of their offices located outside their headquarters. To achieve this goal, the Ministry conducted official language inspections from January 2025 to December 2025 at Software Technology Park of India (STPI), Bhubaneswar; Semiconductor Laboratory, Mohali; National Informatics Centre (NIC), Maharashtra State Unit, Mumbai; Centre for Development of Advanced Computing (C-DAC), Pune; National Informatics Centre (NIC), Uttar Pradesh State Unit, Lucknow; National Institute of Electronics and Information Technology (NIELIT), Lucknow; National Informatics Centre (NIC), Gujarat State Unit, Gandhinagar; Software Technology Park of India (STPI), Gandhinagar; NIC, Madhya Pradesh State Unit, Bhopal; and National Institute of Electronics and Information Technology (NIELIT), Kolkata and C-DAC Hyderabad Centre. Additionally, official language inspections of several offices are proposed.

### 10.1.5 Official Language Inspection by the Parliamentary Committee on Official Language

To analyse the status of implementation of the Official Language Policy in the offices under the administrative control of the Ministry, the Hon'ble Parliamentary Committee on Official Language conducted inspections of STPI, Chennai; ETDC, Chennai; NIELIT, Kozhikode; C-DAC, Thiruvananthapuram; ERTL (South), Thiruvananthapuram; NIC, Punjab Circle, Chandigarh; C-DAC, Mohali; ETDC, Mohali; NIELIT, Kurukshetra; STPI, Mohali; STPI, Pune; C-MET, Pune; ETDC, Pune; EITL, Mumbai; SAMEER, Mumbai; C-DAC, Jasola, New Delhi; STPI, Bhopal; BISAG-N, Gandhinagar; ERTL (East), Kolkata; STPI, Kolkata, NIC Chhattisgarh State Centre, Raipur from January 2025 to December 2025. It is noteworthy that the implementation of the Official Language Policy was found satisfactory in about 80% of the inspected offices and they were awarded satisfactory certificates by the Committee.

### 10.1.6 Ministry's website

Keeping pace with the revolutionary changes taking place in the field of information technology, the website of the Ministry of Electronics and Information Technology has been designed. It has been integrated with the indigenously developed Bhashini tool through which the website of the Ministry can be accessed in Hindi as well as in the 22 Indian languages recognized in the Eighth Schedule of the Constitution. The Bhashini tool, a result of the information technology revolution and far-reaching initiatives like Make in India, is certainly proving to be a powerful tool in realizing the vision of Digital India. Bhashini provides every language speaker in India with the opportunity to connect with every initiative and innovation in the country. The content on the website is updated periodically.

### 10.1.7 Innovative efforts made to promote interest in Hindi

The Ministry of Electronics and Information Technology is concerned with technical work. Therefore, some innovative efforts have been made to progressively increase the use of Hindi in the Ministry's work. The main ones are as follows:

- The Ministry has allocated funds for the purchase of Hindi books, as directed by the Department of Official Language. This includes not only socially useful readable books but also important books on contemporary technical topics.
- As per the orders of the Department of Official Language, an incentive scheme for noting/drafting is also being run in the Ministry.
- To remove the difficulties faced by non-Hindi speaking personnel in working in Hindi language, three programmes have been sanctioned from the Ministry under the Hindi Teaching Scheme being run by the Central Hindi Training Institute. Three (03) non-Hindi speaking officers have been enrolled for training. This includes two (02) officers enrolled for the Prabodh course and one (01) officer enrolled for the Praveen course.
- To maintain interest in reading and writing in the Hindi language and to provide a platform for the officers of the Ministry and its subordinate offices to express their creative abilities, the Ministry is soon going to publish the upcoming issue of its annual in-house magazine '*Spandan*'. The Official Language section has received several articles written originally in Hindi by scientific officers with creative interests, on emerging technologies and the proofreading of these articles is currently underway.
- Under an innovative initiative by the Semiconductor Laboratory, Mohali—an office under the Ministry—an Official Language exhibition was organized under the Ministry's guidance during the Golden Jubilee Celebrations of the Department of Official Language held at Bharat Mandapam, New Delhi, as well as during the Hindi Day celebrations and the 5th All India Official Language Conference held in Ahmedabad, Gujarat. Through this exhibition, the Laboratory not only expressed its commitment to the implementation of the Official Language Policy but also informed the large gathering of people about the process of indigenizing important and strategically significant products such as semiconductor wafer fabs being developed in the national interest. To ensure better implementation of the Official Language Policy, the honourable Home Minister, Shri Amit Shah, awarded

the Laboratory, and the Honourable Minister of Law and Justice, Shri Arjun Ram Meghwal, also released one of their books written originally in Hindi on semiconductor technology.



### 10.1.8 Organisation of Hindi Fortnight

To ensure the progressive use of Hindi in official work, to create a positive environment and to increase the interest of officers/employees in Hindi in official work, a Hindi fortnight was organized in the Ministry from September 1, 2025 to September 15, 2025. During the fortnight, five Hindi competitions were organized: Hindi Essay Writing Competition, Hindi Slogan Writing Competition, Hindi Note and Drafting Competition, Online/Offline Hindi Quiz Competition, and Hindi Poetry Writing/Reciting Competition. A large number of officers and employees of the Ministry enthusiastically participated in these competitions. Successful participants in the competitions were awarded first, second, third, and two consolation prizes.

### 10.1.9 Organisation of Hindi workshops

To remove the hesitation of officers and employees towards conducting official work in Hindi and to promote the use of Official Language Hindi in official work during the year, the following three (03) Hindi Workshops were organized under the chairmanship of Group Head (Official Language):

- **Workshop on 'Bhashini' developed by the Ministry:** Calendar Year 2025 In the first quarter, a workshop was held on the Ministry's translation tool, "Bhashini". Mr. Abhitabh Nag, Chief Operating Officer of the Digital India



Bhashini Division, personally attended the workshop with his team to deliver lectures and presentations. To ensure maximum attendance, email addresses were obtained from the e-mail databases of intra-MeitY and NIC and individual messages were sent to designated participants.

- **Workshop on the Questionnaire of the Parliamentary Official Language Committee:** In the second quarter, a training program on the Questionnaire of the Parliamentary Official Language Committee was organized in hybrid mode in collaboration with C-DAC, Pune. The objective of this program was to equip the Ministry's subordinate institutions with the proper completion of the inspection questionnaire of the Parliamentary Official Language Committee to avoid errors. Senior officials of the Ministry, as well as officials from the Ministry's subordinate institutions, participated in the program both in person and online. The opening address of the training program was delivered by Secretary, MeitY. The Under Secretary, Parliamentary Committee on Official Language, was invited as the guest speaker for the training. In his presence, the inspection questionnaire was discussed point-by-point, ensuring that all the officers present received appropriate solutions to their concerns and questions.
- **Workshop on Implementation of Official Language Policy, Administrative and Functional Hindi:** In the third quarter, a workshop was organized on the topic "Implementation of Official Language Policy and Administrative and Functional Hindi". Newly appointed Assistant Section Officers, Senior Secretariat Assistants, and Junior Secretariat Assistants in the Ministry were nominated for this workshop. Mr. Ashutosh, Deputy Director at the Indian Council of Agricultural Research (ICAR), who has extensive experience in the implementation of the Official Language Policy, was invited as the guest speaker.

#### 10.1.10 Hindi translation

Under Section 3(3) of the Official Language Act, 1963, documents that are required to be issued compulsorily in bilingual form—such as general orders, resolutions, circulars, rules, administrative or other reports, press releases, contracts, agreements, licenses, tender forms, permits, tender notices, notifications, and reports and documents laid before Parliament—were translated from English to Hindi and vice versa as needed on a priority basis. In addition, memorandums of understanding (MoUs), annual reports, RTI documents, follow-up action reports, and various other documents were also translated as required. During the past approximately 12 months, translation work exceeding the prescribed quota by 5,36,457 words was completed at the section level itself. In this regard, the Ministry's Hindi Section has also issued instructions from time to time to the offices under the administrative control of the Ministry to ensure compliance with Section 3(3) of the Official Language Act.

#### 10.2 RTI Matters

There is an RTI Cell in the Ministry, which is the central receiving point for RTI applications/appeals and responsible for overall coordination in respect of RTI matters of MeitY and its organizations. MeitY and its Attached/Subordinate Offices/Societies are separate Public Authorities in terms of Section 2 (h) of RTI Act, 2005. Each of these Public Authorities has its own Central Public Information Officers (CPIOs)/First Appellate Authorities (FAAs). For any information relating to these organizations, applications need to be submitted to the concerned Public Authorities as per provisions of RTI Act, 2005. All Public Authorities also host relevant inputs/documents on their respective websites, as required under Section 4 of the RTI Act. The relevant contents are reviewed and updated periodically by the concerned Public Authorities.

During the period from 01.01.2025 to 31.12.2025, 3973 RTI applications and 160 RTI First Appeals were received through online portal, out of these 3829 RTI applications and 145 RTI First Appeals were disposed of. Further, 230 RTI application and 15 First Appeals were also received offline. Of the total number of 4203 (3973 online + 230 offline) RTI applications received in MeitY, the majority of the applications were related to the following subject matters:

- IT Act
- Social Media

- DPDP Act
- e-Governance services
- online gaming
- PLI Scheme.
- Aadhaar

### 10.3 Public Grievances

Public Grievances Cell in MeitY is headed by the Nodal Grievance Officer.

- During the period from 01.01.2025 to 31.12.2025, 13852 grievances were received through CPGRAMS Portal and out of these, 13574 were disposed of, with the average grievance redressal time of 08 days as against the prescribe time line of 21 days. Detailed information for the period is shown below:

Grievance Source	Brought Forward	Receipt During Period	Total Receipt	Case Disposed During Period	Closing Balance
DARPG	03	153	156	151	05
Direct from complainant	203	10984	11187	10964	223
President Secretariat	43	338	381	378	03
Pension	02	36	38	38	00
PMO	39	2051	2090	2043	47
<b>Total</b>	<b>290</b>	<b>13562</b>	<b>13852</b>	<b>13574</b>	<b>278</b>

During the period from 01.01.2025 to 31.12.2025, 1796 Grievance Appeals were also received though CPGRAMS Portal and out of these, 1641 were disposed of.

The total number of 13970 (13852 online + 118 offline) Public Grievances were received in MeitY during the period from 01.01.2025 to 31.12.2025, the majority of the grievances received were related to the following subject matters:

- CSC
- Digital India/e-Services
- Social Media
- Cyber Security
- NIC
- My Gov
- DPDP Act

### 10.4 Citizens' Charter

The basic objectives of Citizens' Charter are to empower the citizen in relation to public service delivery. It represents the commitment of the organization towards the standard, quality and time frame of service delivery, grievance redressal mechanism, transparency and accountability. The Citizens' Charter is written, voluntary declaration by service providers about service standards, choice, accessibility, non-discrimination, transparency and accountability. It is useful way of defining for the customers the nature of service provision and explicit standards of service delivery. A copy of MeitY's Citizens' Charter is available on the Ministry's website at the following URL: <https://www.meity.gov.in/connect/>

## citizen-engagement

### 10.5 Information & Documentation Centre (Library)

This Ministry has a spacious well-planned Library viz Information and Documentation Centre (I&DC), with an inventory of books, journals, magazines, annual reports and newspapers. It uses RFID based Library Management System to manage acquisition, cataloguing and circulation, of books/journals/magazines. I&DC also provides various other services like Inter-Library loan facility to the officials of the Ministry through DELNET (Developing Library Network) and arranges books/journals/magazines/articles from libraries of various other organizations. Services are also provided to the retired officials of the Ministry and trainees who undertake projects in the Ministry.

The Information & Documentation Centre possesses approximately 20,889/- books on various subject including Electronics, Computer, IT, Computer Languages, Fiction, Artificial Intelligence & Cyber Security. I&DC has books on Hindi and English literature also. I&DC procures on an average 17 books and approximately 34 Journals (Print) per annum and Skillsoft E-books services (Book 24x7) is also made available to the authorized users.

The Ministry is spearheading an Intra-Ministerial initiative viz the Library Consortium, Ministry of Electronics & Information Technology (MCIT). Consortium of the Ministry (MCIT Consortium) comprises the users from the National Informatics Centre (NIC), C-DAC, NIELIT, SAMEER, C-MET, STQC Directorate, STPI, ERNET India, C-DOT. The Ministry provides on-line access to various e-resources i.e. IEEE Journals/Transactions/Proceedings, IEE Journals/Proceedings, ACM Digital Library and ISO Standards to its users through MCIT Library Consortium. I&DC also provides journals/magazines/articles of 30 international publishers through ONOS platform.

I&DC provides Gartner Research and Advisory Services which is useful e-resource consists of reliable global trends & best practices and latest reports on digital technologies.

I&DC also provides “Bloomberg Terminal Services”. The Bloomberg Terminal service is a global, 24-hour a day, financial information network providing real-time and historical pricing, indicative and fundamental data, and customized analytics. Other features include on-demand print and multimedia news and research, extensive electronic-trading capabilities, and a superior communications platform.

### 10.6 Parliament Section

In the Year 2025 the Budget Session, Monsoon Session and Winter Session of the Parliament has been held. During these Sessions 238 number of Parliament Questions in Lok Sabha (14 Starred & 224 Unstarred) and 157 number of Parliament Questions in Rajya Sabha (17 Starred & 140 Unstarred) were admitted and handled by the Parliament Section. These were mainly related to Development of IT Hub, Financial Cyber Crime, Cert-In, Development of Additive Manufacturing (3D Printing) in India, National Knowledge Network(NKN), Global Outage, Incentive for Semiconductor and display ecosystem, Digital India Bill, Uniform Fiscal Support, Robotic Process Automation Lab, Grievance Redressal By Social Media Intermediaries, Visveswaraya Ph.D. Scheme, Development of Metaverse, Big Tech companies, Digital Public Infrastructure and AI, PMGDISHA, Electronic Manufacturing Companies, Research and Development, Online Gamers, Cyber Security Incidents, Progress of Digital India Programme, Future Skills Prime Programme, Digital copyright infringement by online chatbots, Leakage of personal data on Dark Web, Manufacturing of Mobile Phone, Implementation of Digital Personal Data Protection Act, 2023, TIDE 2.0 scheme, Electricity supply to data centres, Tariff rationalisation for smart phone manufacturing, Action against Data Breaches, Semiconductor Industry, Technological expertise for blockchain effectiveness for MSMEs, Digital Personal Data Protection Act (DPDPA), Legislation/Rules for Online Gaming and Online Gambling, Adoption and Development of Artificial Intelligence under PPP Model, Amendment in IT Act to regulate AI, Support to Tech-Startup, Semiconductor chip fabrication, Digital Literacy and Skill Development, Greenfield Semiconductor Fab, Personal Data Mining and PhishingIt, Deepfake, Digital Public Infrastructure, Scheme

for scaling up electronics production, Identified digital villages in Andhra Pradesh, Digi Locker, National Cyber Security Policy, Software Technology Park, Business Process Outsourcing Industry, Generative Artificial Intelligence, NDLM etc.

Department related Parliamentary Standing Committee on Communications and Information Technology has discussed on the following subjects:-

- Evidence of the representatives of the Ministry of Electronics and Information Technology on Demands for Grants (2025-26);
- Examination of the Subject 'Impact of emergence of Artificial Intelligence and related issues' - to have briefing by the representatives of Ministry of Electronics and Information Technology.
- Examination of the Subject 'Impact of Information Technology Agreement in the new age' - to have briefing by the representatives of Ministry of Electronics and Information Technology.
- Examination of the Subject 'Cyber Security- Issues, Challenges and way forward' - to have briefing by the representatives of Ministry of Electronics and Information Technology.
- Examination of the Subject 'Review of mechanism to curb Fake News' - to have briefing by the representatives of Ministry of Electronics and Information Technology.
- Examination of the Subject 'Review of implementation of Laws related to all forms of Media' - to have briefing by the representatives of Ministry of Electronics and Information Technology.

The Parliamentary Committee on Information and Communication Technology Management (ICTM), Rajya Sabha has taken following meetings during their study visits:-

- Usage of Emerging Technologies and steps taken by Public Institutions in Madhya Pradesh to implement them for public services
- Investigating the application of AI-driven predictive models to forecast potential threats to Bandhavgarh's ecosystem & potential for AI to assist in studying tiger behaviour and population dynamics
- Review the cybersecurity protocols & Cyber law enforcements to protect Citizens data
- Digital connectivity in State and rural areas and Overview of Digital India initiatives in remote regions.
- Disaster recovery protocols, secure connectivity solutions in coastal areas especially in Union Territory of Lakshadweep
- ICT growth in UT of Lakshadweep including digital employment trends.
- Digital Finance, ICT Growth and Citizen Data Safety with reference to Andaman and Nicobar Islands
- Architecture, Minimum Bandwidth Assumptions, and Fall-back Modes Drawn from Digital Access Challenges in Andaman and Nicobar Islands
- Digital Finance, ICT Growth and Citizen Data Safety with reference to the State of Tamil Nadu
- Emerging Digital Technology, AI Integration including language tools, Digital Attendance and e-Vidhan Practices etc

The Parliamentary Standing Committee on Communications and Information Technology has selected the following subjects for discussion during the year 2024-25:

- Impact of emergence of Artificial Intelligence and related issues
- Social and digital platforms and their regulation
- Impact of Information Technology Agreement in the new Age

The following Annual Reports of Societies and Notifications of the Ministry of Electronics and Information Technology have been laid on the Table of the Both Houses (Lok Sabha and Rajya Sabha) of the Parliament:

Sl. No.	MeitY and Organisations/Attached Offices	F.Y.	Laid in Lok Sabha	Laid in Rajya Sabha
1.	<b>STPI (Annual Report)</b>	2023-24	04.02.2025	20.12.2024
2.	<b>DIC (Annual Report)</b>	2023-24	04.02.2025	20.12.2024
3.	<b>UIDAI Notification:-</b> Aadhar (Authentication and Offline Verification) Second Amendment Regulations, 2024, under Section 55 of the Aadhar (Targeted Delivery of Financial and Other Subsidies, Benefits and Services) Act, 2016	-	04.02.2025	20.12.2024
4.	<b>CMET(Annual Report)</b>	2023-24	13.02.2025	28.03.2025
5.	<b>NICSI (Annual Report)</b>	2023-24	12.03.2025	21.03.2025
6.	<b>UIDAI(Annual Report)</b>	2023-24	12.03.2025	21.03.2025
7.	<b>SAMEER(Annual Report)</b>	2023-24	12.03.2025	21.03.2025
8.	<b>CDAC(Annual Report)</b>	2023-24	12.03.2025	21.03.2025
9.	<b>ERNET(Annual Report)</b>	2023-24	12.03.2025	21.03.2025
10.	<b>UIDAI Notification:-</b> No. HQ-12013/13/RR/2016-UIDAI(E)  The Unique Identification Authority of India (Appointment of Officers and Employees) Amendment Regulations, 2025 under section 55 of the Aadhar (Targeted Delivery of Financial and Other Subsidies, Benefits and Services) Act, 2016 (18 of 2016)	-	12.03.2025	21.03.2025
11.	<b>UIDAI Notification:-</b> G.S.R. 88(E) The Aadhar Authentication for Good Governance (Social Welfare, Innovation, knowledge) Section 53 of the Aadhar (Targeted Delivery of Financial and other Subsidies, Benefits and Services) Act, 2016 (18 of 2016)	-	12.03.2025	21.03.2025
12.	<b>UIDAI Notification:-</b> i. No. A-12013/13/RR/2016-UIDAI(E)The Unique Identification Authority of India (Appointment of Officers and Employees) Second Amendment Regulations, 2025  ii. No. HQ-16024/4/2021-EU-II-HQ(E-5735) on 'The Aadhaar (Enrolment and Update) First Amendment Regulation, 2025	-	30.07.2025	01.08.2025

Sl. No.	MeitY and Organisations/Attached Offices	F.Y.	Laid in Lok Sabha	Laid in Rajya Sabha
13.	<b>CMET(Annual Report)</b>	2024-25	10.12.2025	12.12.2025
14.	<b>NIELIT (Annual Report)</b>	2024-25	10.12.2025	12.12.2025
15.	<b>UIDAI(Annual Report)</b>	2024-25	17.12.2025	12.12.2025
16.	<b>SAMEER(Annual Report)</b>	2024-25	17.12.2025	12.12.2025
17.	<b>CDAC(Annual Report)</b>	2024-25	17.12.2025	12.12.2025
18.	<b>ERNET(Annual Report)</b>	2024-25	03.12.2025	05.12.2025
19.	<b>STPI (Annual Report)</b>	2024-25	17.12.2025	12.12.2025
20.	<b>BISAG-N (Annual Report)</b>	2024-25	03.12.2025	05.12.2025
21.	<b>SCL (Annual Report)</b>	2024-25	17.12.2025	12.12.2025
22.	<b>UIDAI Notification:-</b> i. No. A-12013/13/RR/2016-UIDAI(E) dated 17.10.2025 ii. No. A-12013/13/RR/2016-UIDAI(E) dated 31.10.2025	-	03.12.2025	05.12.2025
23.	<b>IT Notification:-</b> No. G.S.R. 775(E) dated 22.10.2025	-	03.12.2025	05.12.2025
24.	<b>UIDAI Notification:-</b> i. No. F No. HQ-13073/1/2020-AUTH-II Part (1)/ Comp. No. 12972(E) dated 20.08.2025 ii. No. F No. HQ-16016/1/2023-EU-1-HQ(E) dated 22.08.2025 iii. No. F No. HQ-16021/2/2021-EU-II-HQ(E-6538) dated 22.08.2025	-	10.12.2025	12.12.2025
25.	<b>UIDAI Notification:-</b> No. F No. HQ-16021/2/2021-EU-II-HQ(E-6538) dated 25.11.2025	-	17.12.2025	12.12.2025

### 10.7 Vigilance Unit

Vigilance Unit, Ministry of Electronics and Information Technology (MeitY) is the Nodal Unit for addressing all vigilance matters concerning MeitY and its Organizations under the administrative control of the Ministry. The Vigilance Unit is headed by Joint Secretary, who has also been appointed as Chief Vigilance Officer (CVO) by Central Vigilance Commission (CVC). The CVO with the assistance and support of a team of officials looks into the vigilance matters of MeitY and its organizations and is the Nodal Officer for MeitY for interaction with CVC and CBI. Each of the Autonomous Societies under MeitY are provided with an independent CVO appointed by Secretary, MeitY based on the CVO's recommendation in consultation with CVC. The organizations under MeitY have their own vigilance setup in their respective organizations, who work in close coordination with the Vigilance Unit of the Ministry to ensure effective vigilance administration.

During the year 2025 (Upto December,2025), a total of 39 complaints were received in Vigilance Unit, MeitY which included complaints from Central Vigilance Commission (CVC) and others received through various platforms, including Public Grievance Portal. These complaints primarily involved allegations on favouritism, corruption in recruitment and promotion, violation of CVC guidelines/GFRs and GeM's terms and conditions in tendering process/ hiring of manpower, misuse of official position, harassment, unfair transfer/posting etc.

During the year (upto December, 2025) two major cases were examined/investigated in Vigilance Unit and after taking due action necessary advice was provided to the concerned authorities for bringing in Systemic Improvement in their functioning. Wherever necessary advisories were issued. In disciplinary matters advice of UPSC has been sought before imposing major penalty.

In order to mitigate potential risk of corruption, Vigilance Unit, MeitY conducts regular scrutiny Annual Property Returns of the officers/officials of MeitY. The review aims to identify possession of assets disproportionate to known sources of income, non-intimation of transaction of property etc. During the year 2025 (upto December, 2025) more than 119 Annual Property Returns (APRs) were scrutinized. Necessary directions based on the observations noticed in scrutiny of APRs were conveyed to the concerned authorities with a view to strengthen the vigilance mechanism of this Ministry.

In terms of the advice of the Central Vigilance Commission, MeitY organized a three-months campaign on various Preventive Vigilance activities as a prelude to Vigilance Awareness Week (VAW) 2025 from 18th August 2025 to 17th November 2025. The campaign focused on building awareness and reaffirming the commitment of everyone for upholding integrity, and included training programs for (a) Vigilance guidelines (b) Finance Propriety . As per the directions of Central Vigilance Commission, Vigilance Unit, MeitY observed the Vigilance Awareness Week, 2025 from 27th October to 2nd November 2025. The week commenced with administering of integrity pledge within the premises of Electronics Niketan, MeitY by Secretary, MeitY on 27th October, 2025. A number of activities in the form of training programmes, essay, quiz, slogan, poster/painting competition were conducted and banners on VAW were displayed at prominent places of the organisation to create awareness on vigilance administration amongst officials of MeitY and its organisations.

Random inspections of records were carried out by Vigilance Unit and necessary Systemic Improvement Measures were communicated wherever shortcomings were identified to bring in robust mechanism to curb corruption and unethical practices in public administration and to bring about transparency, fair-play, objectivity, accountability and responsiveness to the aspirations of the citizens. Surprise inspections were carried out with a view to bring in efficiency and accountability. During the VAW-2025, officers of Vigilance Unit visited Office of Controller of Certifying Authorities and National Institute of Electronics and Information Technology for sensitizing the officials on vigilance aspects.

Periodical reports and returns were timely sent to the concerned authorities. Periodic Review Meetings Chaired by Secretary were held for creating awareness on vigilance aspects and procedural matters for all Chief Vigilance Officers (CVOs) of organisations under MeitY and systemic improvement measures advised.

## 10.8 Gender inclusive Initiatives:

### 10.8.1 Introduction

The Ministry of Electronics and Information Technology (MeitY) is driving a comprehensive gender-inclusion agenda to ensure that India's digital transformation is both equitable and empowering. By embedding gender perspectives across its programmes and institutions, MeitY is strengthening women's participation in digital skilling, inclusive digital public infrastructure, cybersecurity, emerging technologies, and public service delivery. These initiatives reflect a long-

term commitment to building accessible, safe, and user-friendly digital ecosystems for women across diverse socio-economic and regional contexts.

MeitY's Attached Offices, autonomous societies, Section 8 companies, and companies registered under the Companies Act, 1956 operationalise this vision through targeted interventions such as women-centric skilling programmes, inclusive datasets, AI-enabled solutions, cybersecurity training, and support for women-led startups. These efforts are complemented by initiatives that enhance market access, improve digital safety, promote language accessibility, and expand entrepreneurial opportunities for women. Collectively, these outcomes underline MeitY's role in promoting a gender-responsive, future-ready digital economy where women not only participate but also lead in the country's innovation and technology landscape.

### 10.8.1.1 Gender Initiatives Across the divisions

#### R&D and Technology Development

Gender inclusion is being actively promoted in MeitY's R&D ecosystem through its Centres of Excellence and R&D institutions, which support women researchers, innovators, and entrepreneurs across strategic technology domains. Gender-sensitive design principles are being incorporated in the development of new technologies, including AI-based video analytics, IoT-enabled city infrastructure, and digital surveillance systems for safe cities. MeitY's R&D investments in quantum communication and cybersecurity are enhancing safety in digital and communication systems by contributing to safer and more resilient communication channels, which are critical in addressing digital safety challenges faced by women.

C-DAC's TETRA Network (CTN), an indigenous system used for emergency and mission-critical communication, is strengthening safety and operational efficiency for women personnel working in police services, disaster response, and healthcare sectors.

#### Cyberlaw, Cybersecurity and Online Safety

The Cyber Shakti initiative is equipping women government officials with the competencies required to serve as Chief Information Security Officers (CISOs) or Deputy CISOs. The Women innovators and women-led cybersecurity startups are being actively encouraged to participate in the national Cyber Security Grand Challenge (CSGC 2.0). Nearly 40% of the funds allocated under cyber law initiatives support projects focused on improving the safety of women and children online.

The Cyber Shikshaa Programme is a flagship initiative focused on training women in cybersecurity with the objective of enhancing employability and increasing women's representation in the cybersecurity workforce.

Various other key initiatives are as follows.

- **Strengthening of the Legal and Policy Framework**

Over the last decade, India has significantly strengthened its cyber law ecosystem through the Information Technology Act, 2000, along with the rules framed thereunder and subsequent amendments, as well as the Digital Personal Data Protection Act, 2023 and the rules made thereunder. These legislative frameworks address emerging digital harms, including obscenity, sexually explicit content, non-consensual sharing of intimate images, online trolling and harassment, violation of bodily privacy, cyberstalking, synthetic and manipulated content including AI-generated or AI-altered content such as deepfakes, and impersonation and identity-based misuse.

Key reforms under these frameworks include time-bound content removal obligations, enhanced due diligence requirements for intermediaries, institutionalised grievance redressal mechanisms, and platform accountability measures. These reforms aim to prevent misuse of online platforms and enhance the safety of users, particularly women, in the digital ecosystem.

- **Technology-Led Enforcement and Platform Accountability**

Under the Information Technology (Intermediary Guidelines and Digital Media Ethics Code) Rules, 2021, as amended and proposed to be further amended in relation to Synthetically Generated Information (SGI), intermediaries—particularly significant social media intermediaries—are required to act expeditiously to remove or disable access to unlawful content, including content involving nudity, impersonation, or deceptive manipulation, upon receipt of actual knowledge or user complaint, in accordance with the prescribed timelines of 24 hours.

Intermediaries are also required to exercise due diligence, including the deployment of appropriate automated tools or other technological measures, to prevent the re-upload of content previously removed pursuant to law. They are further required to disclose, label, or otherwise make identifiable synthetic or manipulated content, to the extent technically feasible and in accordance with applicable law, and to adopt safety-by-design measures, including responsible content-handling practices and user-facing safeguards.

The proposed amendments relating to Synthetically Generated Information (SGI) seek to explicitly bring synthetic and AI-generated content within the regulatory due diligence framework, thereby strengthening intermediary accountability and enabling timely mitigation of technology-enabled harm.

- **Empowering Women Through Data Protection Rights**

The Digital Personal Data Protection Act, 2023 introduces a rights-based framework that empowers women through the right to access personal data, the right to erase personal data, the right to grievance redressal, the right to informed consent, and nominee support for vulnerable groups. The Act prioritises inclusivity, as demonstrated by the use of the pronoun “She” to normalise women’s agency in digital rights. A fully digital and citizen-friendly Data Protection Board ensures accessible grievance redressal across the country.

**Startup Ecosystem and Women Entrepreneurs**

Under MeitY’s startup support schemes, approximately 30% of startups supported under the SAMRIDH programme are women-led. Under the Next Generation Incubation Scheme (NGIS), 42.5% of supported startups are women-led, with ₹14.6 crore disbursed to women founders.

The MeitY Startup Hub (MSH) provides mentorship, seed funding, technical guidance, and incubation support to startups, helping reduce gender gaps while strengthening women’s leadership in the ICT and innovation sectors.

**Electronics Manufacturing and Skilling**

Training centres, skill development facilities, and incubation hubs established within Electronics Manufacturing Clusters (EMCs) are equipping women with skills relevant to electronics production and manufacturing, thereby enhancing their employability and participation in the electronics industry.

**10.8.1.2 Gender Initiatives of Attached Offices, Autonomous Societies, Section 8 Companies, and Companies Registered under the Companies Act, 1956**

- **IndiaAI**

IndiaAI has undertaken significant initiatives to promote gender inclusion in the national AI ecosystem by expanding women’s participation through research fellowships, compute access, hackathons, startup financing, and inclusive datasets. Dedicated programmes such as AI for Her and YuvAI, along with collaboration with UN Women for the development of a compendium on gender and AI to be released in February 2026, anchor gender empowerment within emerging technologies.

Under IndiaAI Compute, 38,231 GPUs have been enabled at a 40% subsidy, with 23 women onboarded and 7 women receiving compute allocations. Women constituted 70% of applicants under the IndiaAI Future Skills research fellowship. Startup financing support was extended to 10 AI startups, including 3 women-founded enterprises. Twelve foundation model proposals were supported with women researchers included as part of inclusive teams. AI Kosh hosts over 3,000 datasets, including several focused on women's health and welfare. AI hackathons were conducted with dedicated prize categories for women participants.

- **NIELIT**

NIELIT continues to be one of MeitY's largest contributors to women's digital skilling through its nationwide training programmes in IT, electronics, digital literacy, and emerging technologies. Over the last three years, NIELIT has trained approximately 27 lakh candidates across diverse digital, IT, and electronics courses, of which over 10 lakh candidates are women.

During 2022–2023, NIELIT trained 7,95,744 candidates in total, including 3,05,444 women. In 2023–2024, a total of 9,00,375 candidates were trained, including 3,27,811 women. In 2024–2025, NIELIT trained 10,32,970 candidates, including 3,84,628 women. These figures span degree and diploma-level courses, skill-based long-term courses, skill-based short-term courses, and digital competency courses.

NIELIT also organised the 1st IEEE Uttar Pradesh Women in Engineering Conference (UPWIECON-2025) on October 30–31, 2025, in Dehradun, under the banner of the IEEE UP Section and the Women in Engineering (WIE) IEEE UP Section affinity group. The conference aimed to promote women in engineering and served as a global platform for women technologists, researchers, and academicians.

Under the multi-state Skill Development Programme covering Odisha, Jharkhand, West Bengal, and Bihar, a women-specific target of 15,012 trainees was set. Under the Skill Development for Digital Jammu & Kashmir and Ladakh project, a women-specific target of 2,835 candidates was set across both Union Territories. Under the Employability Enhancement and Livelihood Training Programme (EELTP) for SC/ST and EWS women youth through capacity building and skill development in IECT, a women-specific target of 10,460 EWS women was set.

- **C-DAC**

C-DAC supports women across technology, safety, livelihood, and capacity-building programmes with strong outreach in rural and vulnerable communities. Under the Weavers and Artisans project in BTC, Assam, 3,552 rural women were supported. Under the ERSS-112 (Nirbhaya Scheme), 17.27 lakh women were assisted. A total of 3,000 tribal women were screened for cervical cancer out of 77,000 women surveyed.

Under the PACE Computer Education Programme, 36,629 women benefited. Under the National Supercomputing Mission HRD programme, 1,381 women, constituting 24% of trainees, were trained. Additionally, 887 women officers were trained under Cyber Shakti, 1,892 women faculty and students were trained under Cyber GYAN, and 54 women from Tier-II and Tier-III cities were trained under Cyber Shiksha.

- **STPI**

STPI promotes women entrepreneurship through incubation support, financial incentives, and specialised Centres of Entrepreneurship, with a focus on women-led startups in emerging technologies. Women-led startups are offered an additional 5% discount in incubation centres, and 72 women entrepreneurs are currently incubated.

Across 24 Centres of Entrepreneurship, STPI has supported 827 startups, including 165 women-led startups, with 5 startups developing women-oriented products. Under Next Generation Incubation Scheme (NGIS), 686 startups were supported, of which 292 were women-led, accounting for 42.56%. In FY 2024–25, STPI supported 159 startups, including 63 women-led startups, and funded 11 women-led startups.

- **Digital India Corporation (DIC)**

Digital India Corporation manages several citizen-centric, women-focused digital platforms that enhance safety, livelihood, and inclusion across rural and urban India. The e-Saras platform is a 100% women-led rural e-commerce initiative with over 1,200 products listed. The NCW Helpline has handled over 5.86 lakh calls, registered over 9,800 grievances, and delivered more than 6,100 counselling sessions across 36 States and Union Territories.

The Poshan Tracker covers over 13 lakh Anganwadi Centres and reaches more than 10 crore women and child beneficiaries. Under IndiaHandmade, 1,448 women artisans have been onboarded out of a total of 2,666 sellers. Under Kisan Sarathi 2.0, 53 lakh women farmers have been registered out of a total of 279 lakh farmers.

- **Common Services Centres (CSC)**

Common Services Centres empower rural women entrepreneurs who deliver essential digital, financial, and public services at the last mile. Women constitute 14.6% of Village Level Entrepreneurs (VLEs), amounting to 0.79 lakh out of a total of 5.4 lakh VLEs. Under the DigiPay Sakhi initiative, over 34,000 SHG women are delivering AEPS-enabled banking services in villages. Women VLEs are playing a key role in driving financial inclusion, telemedicine services, and citizen service delivery in rural India.

- **Bhashini**

Bhashini strengthens digital inclusion through multilingual AI and language technologies, enabling women—especially in rural areas—to access digital services and participate effectively in digital systems. Initiatives such as the Pink Police Goa multilingual application enhance women’s safety, while the Lakhpati Didi (Shrutlekh) initiative provides speech-to-text tools for rural women entrepreneurs. The Meri Pehchaan application supports nurses and women healthcare workers.

Bhashini undertakes targeted outreach to Self-Help Groups, rural collectives, and women-led enterprises, prioritises funding for women-focused skilling and leadership programmes, and ensures representation of women’s voices in training datasets.

- **NeGD**

The National e-Governance Division (NeGD) drives women’s participation in digital public platforms and ensures gender-responsive policies across national e-governance services. Women constitute 43.53% of DigiLocker users, reflecting strong adoption.

Major citizen-facing platforms such as UMANG, MyScheme, API Setu, and NSSO demonstrate strong gender-balanced adoption, with approximately 50% women users across high-volume services. Skill-building and digital capacity initiatives—including Capacity Building Phases I–III, UI/UX4G, and DPDP Awareness programmes—show growing participation of women, with an estimated 30% representation among trained officials, designers, developers, and data users. Overall, NeGD’s platforms serve millions of women every month, reinforcing digital inclusion, access to entitlements, and improved user experience through gender-responsive design and participation.

## Annexure-I

### Approval of Union Cabinet for extension of the Digital India Programme for the duration of 15<sup>th</sup> Finance Commission

The Government had launched the DIP in July 2015 with three key vision areas, namely digital infrastructure as a core utility to every citizen, governance and services on demand, and digital empowerment of citizens. The overall goal is to ensure that digital technologies improve the life of every citizen, expand India's digital economy, and create investment and employment opportunities. It has also helped in the delivery of services directly to beneficiaries in a transparent manner. In the process, India has emerged as one of the pre-eminent nations of the world to use technology to transform the lives of its citizens.

The Government, in August 2023, approved the extension of the DIP with a total outlay of Rs 14,903.25 Crore for the period of 15th Finance Commission i.e., 2021-22 to 2025-26.

The extension of the programme has the following major benefits:

- 16.66 lakh+ candidates enrolled/trained in various courses under the Future Skills PRIME Programme.
- Under the awareness component of Information Security & Education Awareness Phase (ISEA) Programme, 2,552 awareness workshops on Information Security have been organized through direct/virtual mode for school & colleges students, teachers, faculty, Government personnel, general user 5,71,544 participants and around 10 crore estimated beneficiaries have been covered through indirect mode.
- At present, about 2390 Central and State Govt. services are available on UMANG platform from 240 departments of Central and State Government of 29 States/UTs and many more are continuously being on-boarded.
- 38 supercomputers have been deployed under the National Super Computer Mission.
- Bhashini, the AI-enabled multi-language translation tool, currently supports 36+ languages for text translation, 22+ languages for voice, and hosts 1.5 million-term multilingual glossary.
- Modernisation of the NKN under which 1869 links have been extended to institutions.
- DigiLocker launched EntityLocker — a dedicated digital locker for organizations, institutions, and government entities. EntityLocker has onboarded 40,739 entities and 374 issuers marking a transformative step in institutional document management.
- The **GENESIS (Gen-Next Support for Innovative Startups)** scheme envisages scaling up about 1,600 technology startups to discover, nurture and grow technology startups. Under the scheme, a total of 253 startups has been supported till now

New initiatives in the area of cyber security including the development of tools and integration of more than 200 sites with the National Cyber Coordination Centre

The 16th Finance Commission (XVIFC) was constituted under Article 280 of the Indian Constitution to recommend fiscal transfers between the Union and States for the 2026-2031 period. The XVIFC's recommendations are crucial for India's fiscal federalism, guiding financial resource allocation and addressing contemporary economic challenges, playing a vital role in equitable development across states.

**Annexure - II**
**Summary of important Audit observations**

**Audit Report No. 01 of 2025 of the Comptroller and Auditor General of India for the year ended 31 March (Compliance Audit)**

**Chapter 2 Ministry of Electronics and Information Technology (MeitY)**

Sl. No.	Year	No. of Paras/ PAC reports on which ATNs have been submitted to PAC after vetting by Audit	Details of the Paras/PAC reports on which ATNs are pending		
			No. Of ATNs not sent by the Ministry even for the first time	No. Of ATNs sent but returned with observations and Audit is awaiting their resubmission by the Ministry	No. of ATNs which have been finally vetted by audit but have not been submitted by the Ministry to PAC
1.	Report No. 1 of 2025	2	Nil	Nil	Nil

**A National Knowledge Network (NKN):**

National Knowledge Network (NKN) is a high-speed information network that connects all universities, libraries, laboratories, hospitals and agricultural institutions and was approved in March 2010, by the Cabinet Committee on Infrastructure (CCI) for ten-year period with a total outlay of ₹5,990 crore to connect 1500 institutions. Subsequently, the project got four extensions i.e., up to 31 March 2024, with the last extension revising the project outlay to ₹6,548.20 crore.

The Project achieved its connectivity milestone within the approved outlays. However, the financial viability of the Project beyond the period of government budgetary support has not been worked out. The implementation and enforcement of its Internet Protocol (IP) Policy and the signing of Memorandum of Understanding (MoU) with the user institutions to ensure network security to ensure upkeep of the hardware provided under NKN, is still a work in progress. Further, deficient bandwidth utilization by the institutions and inadequate monitoring of hired/de-hired links based on usage details acted as a drain on financial resources for the Project. Deficiencies in the execution of Annual Maintenance Contracts (AMCs) were also observed. Ministry could not implement its own in-principle idea of providing a long-distance network from three service providers in North-East India to ensure redundancy.

**B. Modified Special Incentives Package Scheme (M-SIPS):**

To promote large scale manufacturing in the Electronics System Design and Manufacturing (ESDM) sector, Government of India introduced (July 2012) Modified-Special Incentives Package Scheme (M-SIPS). The scheme envisaged providing financial incentive in the form of reimbursement of 20 per cent on investments made by a business in the form of capital expenditure in Special Economic Zones (SEZs) and 25 per cent in non-SEZs. In addition, Excise/ Countervailing Duty (CVD) on capital equipment would also be reimbursed. The scheme was open for applications up to December 2018 or till the incentive commitment reached ₹10,000 crore, whichever was earlier. The total investment of ₹36,991 crore (April 2023) was made by the applicants and incentives amounting to ₹2,136 crore disbursed. However, the investments were on limited verticals.

Planning deficiencies with numerous amendments affect policy consistency. Delays in appraisal of applications, verification and disbursements of incentives at various stages, both within and outside the Ministry hampered the implementation. We observed lapses in appraisal as well as verification of claims. Monitoring was hampered due to delay in development of the portal and non-submission of quarterly progress reports by the applicants.

## Annexure - III

## Ministry of Electronics and Information Technology (Employees structure as on 01.01.2026)

Group/Class	Total No. of Emp.	SC	ST	OBC	EWS	PWD
Group 'A'	200	24	13	43	03	04
Group 'B' (Gazetted)	59	16	06	03	00	02
Group 'B' (Non-Gazetted)	86	13	03	23	02	04
Group 'C' (Non-Gazetted)	205	28	10	56	17	07

(As on 31.12.2025 S&amp;T and Non-S&amp;T Gazetted and Non-Gazetted Posts)

## 2. Data on Backlog Reserved Vacancies

(As on 31.12.2025 S&amp;T and Non-S&amp;T Gazetted and Non-Gazetted Posts)

Group/Class	SC			ST			OBC			EWS			PWD		
	Vacancies	Filled up	Un-filled	Vacancies	Filled up	Un-filled	Vacancies	Filled up	Un-filled	Vacancies	Filled up	Un-filled	Vacancies	Filled up	Un-filled
Group 'A'	03 (S&T-02 Non S&T-01)	00	03	01 S&T	00	01	05	00	05	10 S&T	00	10	02 S&T	00	02
Group 'B' (Gazetted)	-	-	-	-	-	-	-	-	-	-	-	-	-	-	-
Group 'B' (Non-Gazetted)	09	00	09	02	00	02	-	-	-	-	-	-	-	-	-
Group 'C' (Non-Gazetted)	-	-	-	-	-	-	04	04	-	-	-	-	-	-	-

**Note – Reasons for unfilled vacancies:** S&T-The recruitment process for the above mentioned backlog vacancies are currently under way.

**Non-S&T-** No eligible candidate is available.

**Group-B (Non-Gazetted)-** Vacancies remained unfilled due to unavailability of eligible candidates/SP&LDCE mode.

**Group-C (Non-Gazetted)-** Vacancies remained unfilled due to unavailability of eligible candidates/SP&LDCE mode.

## Annexure - IV

**MINISTRY OF ELECTRONICS AND INFORMATION TECHNOLOGY****List of Abbreviations**

AEBAS	Aadhaar Enabled Biometric Attendance System
AEPS	Aadhaar Enabled Payment System
AI	Artificial Intelligence
AKAM	Azadi Ka Amrit Mahotsav
API	Application Programming Interface
ASIC	Application Specific Integrated Circuit
ASP	Application Service Provider
ASR	Automatic Speech Recognition
ATPG	Automatic Test Pattern Generation
BHIM	Bharat Interface for Money
BISAG-N	Bhaskaracharya National Institute for Space Applications and Geo - informatics
BOSS	Bharat Operating System Solutions
BRAP	Business Reform Action Plans
BSNL	Bharat Sanchar Nigam Limited
CCTNS	Crime and Criminal Tracking Network & Systems
C-DAC	Centre for Development of Advanced Computing
CEDA	Centre of Excellence for Data Analytics
CERT-In	Indian Computer Emergency Response Team
CFC	Common Facility Centre
CGIT	Central Government Industrial Tribunal
CIPET	Central Institute of Plastics Engineering & Technology
C-MET	Centre for Materials for Electronics Technology
CMTI	Central Manufacturing Technology Institute
COSEM	Companion Specification for Energy Metering
CPGRAMS	Centralized Public Grievance Redress and Monitoring System
CPS	Certification Practice Statement
CRL	Certificate Revocation List
CSC	Common Services Centre
CSSS	Champion Service Sector Scheme
CTDP	Comprehensive Telecom Development Plan
C2SD	Chip to System Design
DAPSC	Development Action Plan for Scheduled Castes

DBT	Direct Benefit Transfer
DDOS	Distributed Denial of Service
DEPwD	Department of Empowerment of Persons with Disabilities
DGHR	Directorate General of Human Resource Development
DIC	Digital India Corporation
DIHAR	Defence Institute of High-Altitude Research
DIP	Digital India Program
DILRMP	Digital India Land Records Modernization Programme
DLC	Digital Life Certificate
DLMS	Device Language Message Specification
DNS	Domain Name System
DPIIT	Department for Promotion of Industry and Internal Trade
DSC	Digital Signature Certificate
EGDI	eGovernment Development Index
EMC	Electronics Manufacturing Clusters
EoDB	Ease of Doing Business
EoL	Ease of Living
ERNET	Education and Research Network
ESP	eSign Service Provider
eTaal	Electronic Transaction Aggregation and Analysis Layer
FANUC	Fuji Automatic Numerical Control
FINTECH	Financial Technologies
FOSS	Free and Open Source Software
FSOC	Free Space Optical Connectivity
GeM	Government e-Marketplace
GSTN	Goods and Services Tax Network
G2E	Government to Employee
G2X	Government-to-X
HRD	Human Resource Development
IBM	Indian Bureau of Mines
iCAS	Indian Conditional Access System
ICJS	Interoperable Criminal Justice System
ICT	Information and Communication Technology
I&DC	Information and Documentation Centre (i.e. Library)
IIFPT	Indian Institute of Food Processing Technology
IIDS	Implementation of Interactive Information Dissemination System

IIT	Indian Institute of Technology
INCEP	Integrated Citizen Engagement Platform
IndEA	India Enterprise Architecture
InDEA	India Digital Ecosystem Architecture
IoT	Internet of Things
ISEA	Information Security & Education Awareness
IVFRT	Immigration, Visa, and Foreigners Registration & Tracking
JAM	JanDhan, Aadhaar and Mobile
KMS	Knowledge Management System, Key Management System
LDAP	Lightweight Directory Access Protocol
LMS	Learning Management System
MAQAN	Metro Area Quantum Access Network
MDoNER	Ministry of Development for North-Eastern Region
MeitY	Ministry of Electronics and Information Technology
MMIC	Monolithic Microwave Integrated Circuit
MNRE	Ministry of New and Renewable Energy
MSME	Ministry of Micro, Small and Medium Enterprises
MTS	Mining Tenement System
MSDE	Ministry of Skill Development and Entrepreneurship
M-SIPS	Modified Special Incentive Package Scheme
NaMPET	National Mission on Power Electronics Technology
NAPS	National Portal for Rooftop Solar
NCMEC	National Centre for Missing and Exploited Children
NCRP	National Cybercrime Reporting Portal
NDUW	National Database of Unrecognised Workers
NEBPS	North-East BPO Promotion Scheme
NCoG	National Centre of Geo-informatics
NCCC	National Cyber Coordination Centre
NCPP	National Cyberpolice Portal
NCSC	National Career Service Centres
NeGD	National e-Governance Division
NDC	NER -National Data Centre in North -East Region
NDEAR	National Digital Education Architecture
NER	North- Eastern Region
NERS	Nationwide Emergency Response System
NeVA	National e Vidhan Application

NavIC	Navigation with Indian Constellation
NFVI	Network Function Virtualization Infrastructure
NGDRS	National Generic Document Registration System
NIC	National Informatics Centre
NICSI	National Informatics Centre Services Inc.
NIDEC	Nippon Densan Corporation
NIDHI	National Integrated Database of Hospitality Industry
NIELIT	National Institute of Electronics & Information Technology
NJGD	National Judicial Data Grid
NLCPR	Non-Lapsable Central Pool of Resources
NSSO	National Single Sign-On
NKN	National Knowledge Network
NMM	National Mission on Manuscripts
NPP	National Power Portal
NREN	National Research and Education Network
OCSP	Online Certificate Status Protocol
ONDC	Open Network for Digital Commerce
ORS	Online Registration System
PENCiL	Platform for Effective Enforcement for No Child Labour
PFMS	Public Financial Management System
PMAY	Pradhan Mantri Awas Yojana
PMGDISHA	Pradhan Mantri Gramin Digital Saksharta Abhiyan
PMSYSM	Pradhan Mantri Shram Yogi Maandhan Yojana
PRAGATI	Proactive Governance and Timely Implementation
PRIME	Project Review & Information Management Electronics System
QGIS	Quantum Geographic Information System
RESECO	Remote Sensing and Communication Centre
RTL	Register-Transfer Level
SAMEER	Society for Applied Microwave Electronics Engineering and Research
SANKALP	Skill Acquisition and Knowledge Awareness for Livelihood Promotion
SCAN	Subsidy Claims Application for NFSA
SCOSTA	Smart Card Operating System Specification for Transport Applications
SDWAN	Software-Defined Wide Area Network
SEZ	Special Economic Zone
SFIO	Serious Fraud Investigation Office
SID	Skill India Digital

SMDP	Special Manpower Development Programmes
SMITHA	Smart Meter Integrated Testing and Higher Analysis
SNMS	Summons and Notices Management System
SPECS	Scheme for Promotion of Manufacturing of Electronic Components and Semiconductors
SSDG	State Service Delivery Gateway
STPI	Software Technology Parks of India
SWASTHA	Smart Wearable Advanced nanoSensing Technologies in Healthcare ASICs
TCPS	Tactile Cyber-Physical System
TDIL	Technology Development for Indian Languages
TDK	Tokyo Denki Kagaku Kōgyō K.K.
TTS	Text to Speech
UIDAI	Unique Identification Authority of India
UMANG	Unified Mobile Application for New -Age Governance
ULPIN	Unique Land Parcel Identifier Number
UPI	Unified Payment Interface
USOF	Universal Services Obligation Fund
USSD	Unstructured Supplementary Service Data
USSP	Unified Shram Suvidha Platform
UTTRA	Universal Transparent Tracking of Applications
UX4G	User experience for Government Websites & Apps
VVPAT	Voter Verifiable Paper Audit Trail
X2X	Anything-to-Anything
YUVAi	Youth for Unnati and Vikas with Artificial Intelligence





सत्यमेव जयते

**Ministry of Electronics and Information Technology, Government of India**

📍 **Electronics Niketan** 6, CGO Complex, Lodhi Road, New Delhi - 110003, India

🌐 [www.meity.gov.in](http://www.meity.gov.in)

